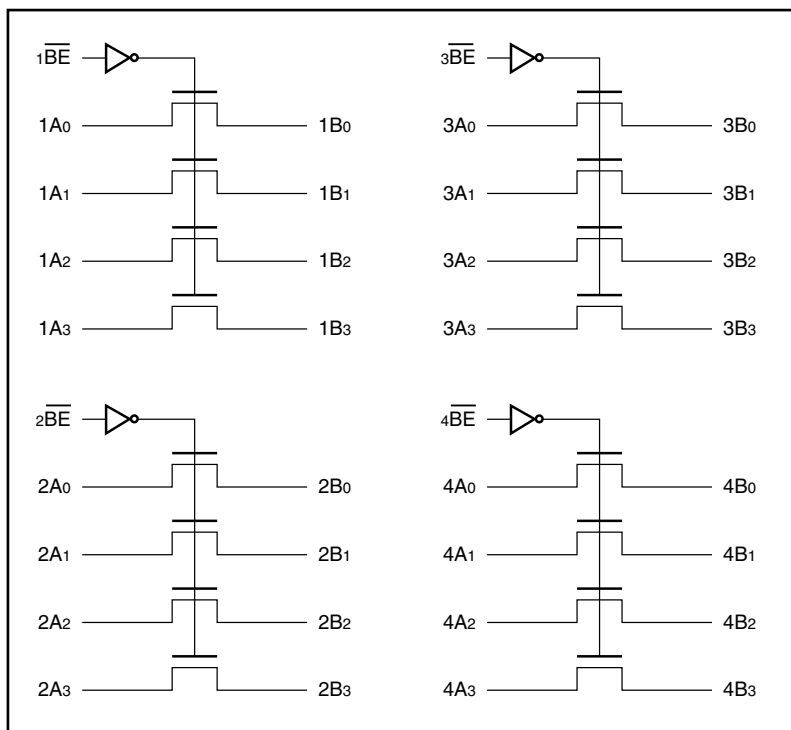
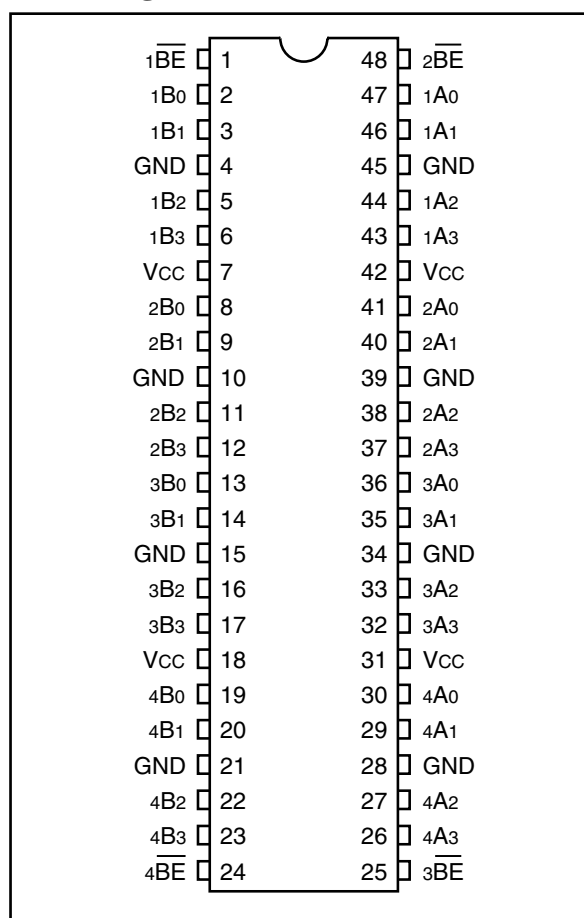

Features:

- Near-Zero propagation delay
- 5Ω switches connect inputs to outputs
- Direct bus connection when switches are ON
- Ultra-low quiescent power (0.2 μA typical)
– Ideally suited for notebook applications
- Pin compatible with 74 series 16244
- Industrial operating temperature: -40°C to +85°C
- Packaging (Pb-free & Green available):
 - 48-pin, 240 mil-wide plastic TSSOP (A)
 - 48-pin, 150 mil-wide plastic BQSOP (B)
 - 48-pin, 300 mil-wide plastic SSOP (V)

Description:

Pericom Semiconductor's PI5C16244 is a 16-bit, 4-port bus switches that is pin compatible with the 74 series 16244 16-bit driver. Four enable signals (\overline{nBE}) turn the switches on. The bus switch creates no additional propagation delay or additional ground bounce noise.

Block Diagram

Pin Configuration

Truth Table⁽¹⁾

Function	\overline{nBE}	nA_{0-3}
Disconnect	H	Hi-Z
Connect	L	nB_{0-3}

Note:

1. H = High Voltage Level; L = Low Voltage Level; Hi-Z = High Impedance

Pin Description

Pin Name	I/O	Description
\overline{nBE}	I	Bus Enable Input (Active LOW)
nA_{0-3}	I/O	Bus A
nB_{0-3}	I/O	Bus B

Maximum Ratings

(Above which the useful life may be impaired. For user guidelines, not tested.)

Storage Temperature	-65°C to +125°C
Ambient Temperature with Power Applied	-40°C to +85°C
Supply Voltage to Ground Potential (Inputs & V _{CC} Only)	-0.5V to +7.0V
Supply Voltage to Ground Potential (Outputs & D/O Only)	-0.5V to +7.0V
DC Input Voltage	-0.5V to +7.0V
DC Output Current.....	120 mA
Power Dissipation	0.5W

Note: Stresses greater than those listed under MAXIMUM RATINGS may cause permanent damage to the device. This is a stress rating only and functional operation of the device at these or any other conditions above those indicated in the operational sections of this specification is not implied. Exposure to absolute maximum rating conditions for extended periods may affect reliability.

DC Electrical Characteristics (Over the Operating Range, T_A = -40°C to +85°C, V_{CC} = 5V ±10%)

Parameters	Description	Test Conditions ⁽¹⁾	Min.	Typ ⁽²⁾	Max.	Units
V _{IH}	Input HIGH Voltage	Guaranteed Logic HIGH Level	2.0			V
V _{IL}	Input LOW Voltage	Guaranteed Logic LOW Level	-0.5		0.8	
I _{IH}	Input HIGH Current	V _{CC} = Max., V _{IN} = V _{CC}			±1	μA
I _{IL}	Input LOW Current	V _{CC} = Max., V _{IN} = GND			±1	
I _{OZH}	High Impedance Output Current	0 ≤ A, B ≤ V _{CC}			±1	
V _{IK}	Clamp Diode Voltage	V _{CC} = Min., I _{IN} = -18mA		-0.7	-1.2	V
I _{OS}	Short Circuit Current ⁽³⁾	A (B) = 0V, B (A) = V _{CC}	80			mA
V _H	Input Hysteresis at Control Pins			150		mV
R _{ON}	Switch On-Resistance ⁽⁴⁾	V _{CC} = Min., V _{IN} = 0.0V, I _{ON} = 48 mA		5	7	Ω
		V _{CC} = Min., V _{IN} = 2.4V, I _{ON} = 15 mA		10	15	

Capacitance (T_A = 25°C, f = 1 MHz)

Parameters ⁽⁵⁾	Description	Test Conditions	Typ	Max.	Units
C _{IN}	Input Capacitance	V _{IN} = 0V		6	pF
C _{OFF}	A/B Capacitance, Switch Off			7	
C _{ON}	A/B Capacitance, Switch On			14	

Notes:

- For Max. or Min. conditions, use appropriate value specified under Electrical Characteristics for the applicable device type.
- Typical values are at V_{CC} = 5.0V, T_A = 25°C ambient and maximum loading.
- Not more than one output should be shorted at one time. Duration of the test should not exceed one second.
- Measured by the voltage drop between A and B pin at indicated current through the switch. On-Resistance is determined by the lower of the voltages on the two (A,B) pins.
- This parameter is determined by device characterization but is not production tested.

Power Supply Characteristics

Parameters	Description	Test Conditions ⁽¹⁾		Min.	Typ ⁽²⁾	Max.	Units
I _{CC}	Quiescent Power Supply Current	V _{CC} = Max.	V _{IN} = GND or V _{CC}		0.1	3.0	μA
ΔI _{CC}	Supply Current per Input @ TTL High	V _{CC} = Max.	V _{IN} = 3.4V ⁽³⁾			2.5	mA
I _{CCD}	Supply Current per Input per MHz ⁽⁴⁾	V _{CC} = Max., A and B Pins Open n $\overline{\text{BE}}$ = GND Control Input Toggling 50% Duty Cycle				0.25	mA/

Notes:

- For Max. or Min. conditions, use appropriate value specified under Electrical Characteristics for the applicable device.
- Typical values are at V_{CC} = 5.0V, +25°C ambient.
- Per TTL driven input (V_{IN} = 3.4V, control inputs only); A and B pins do not contribute to I_{CC}.
- This current applies to the control inputs only and represent the current required to switch internal capacitance at the specified frequency. The A and B inputs generate no significant AC or DC currents as they transition. This parameter is not tested, but is guaranteed by design.

Switching Characteristics over Operating Range

Parameters	Description	Test Conditions ⁽¹⁾	PI5C16244		Unit
			Com.		
			Min	Max	
t _{PLH} t _{PHL}	Propagation Delay ^(2,3) xAx to xBx	C _L = 50pF R _L = 500Ω		0.25	ns
t _{PZH} t _{PZL}	Bus Enable Time x $\overline{\text{BE}}$ to xAx or xBx		1.5	5.6	
t _{PHZ} t _{PLZ}	Bus Disable Time x $\overline{\text{BE}}$ to xAx or xBx		1.5	5.2	

Notes:

- See test circuit and wave forms.
- This parameter is guaranteed but not tested on Propagation Delays.
- The bus switch contributes no propagational delay other than the RC delay of the On-Resistance of the switch and the load capacitance. The time constant for the switch alone is of the order of 0.25 ns for 50 pF load. Since this time constant is much smaller than the rise/fall times of typical driving signals, it adds very little propagational delay to the system. Propagational delay of the bus switch when used in a system is determined by the driving circuit on the driving side of the switch and its interaction with the load on the driven side.

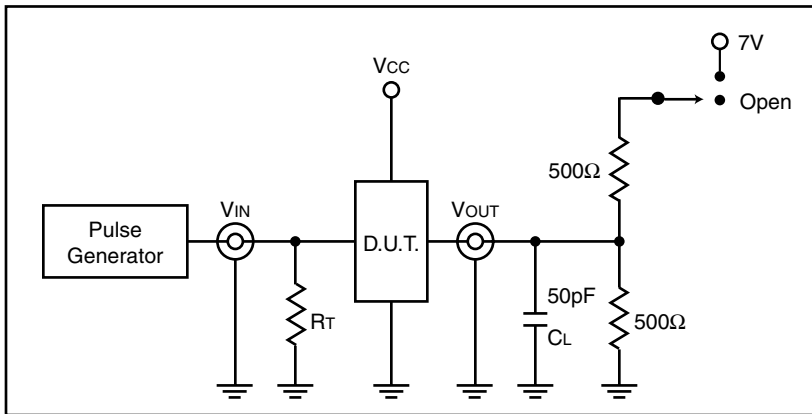
Test Circuit

Switch Position

Test	Switch
Disable LOW	Closed
Enable LOW	Closed
t_{PD}	Open

Definitions:

C_L = Load capacitance (includes jig and probe capacitance)

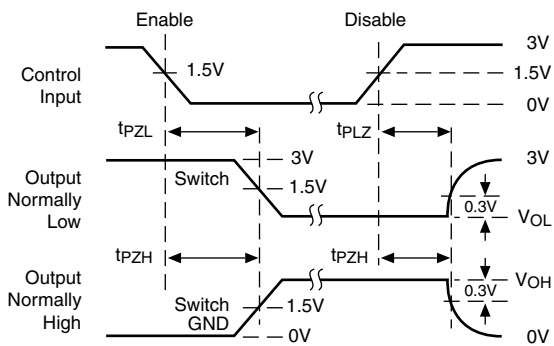
R_T = Termination resistance (should be equal to Z_{OUT} of the pulse generator)

Enable and Disable Timing Diagram

1. Input Control Enable = Low; Input Control Disable = High
2. Pulse Generator for all pulses:
Rate ≤ 1.0 MHz; $Z_{OUT} \leq 50\Omega$; $t_r, t_f \leq 2.5$ ns

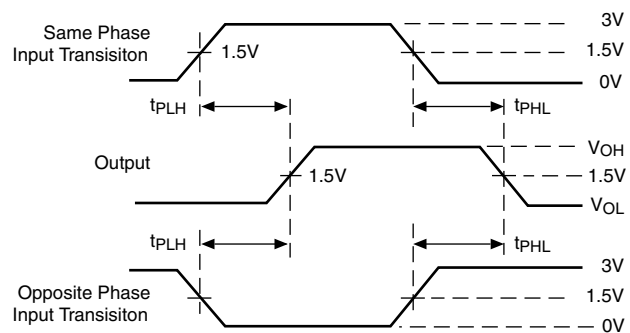
Propagation Delay Diagram

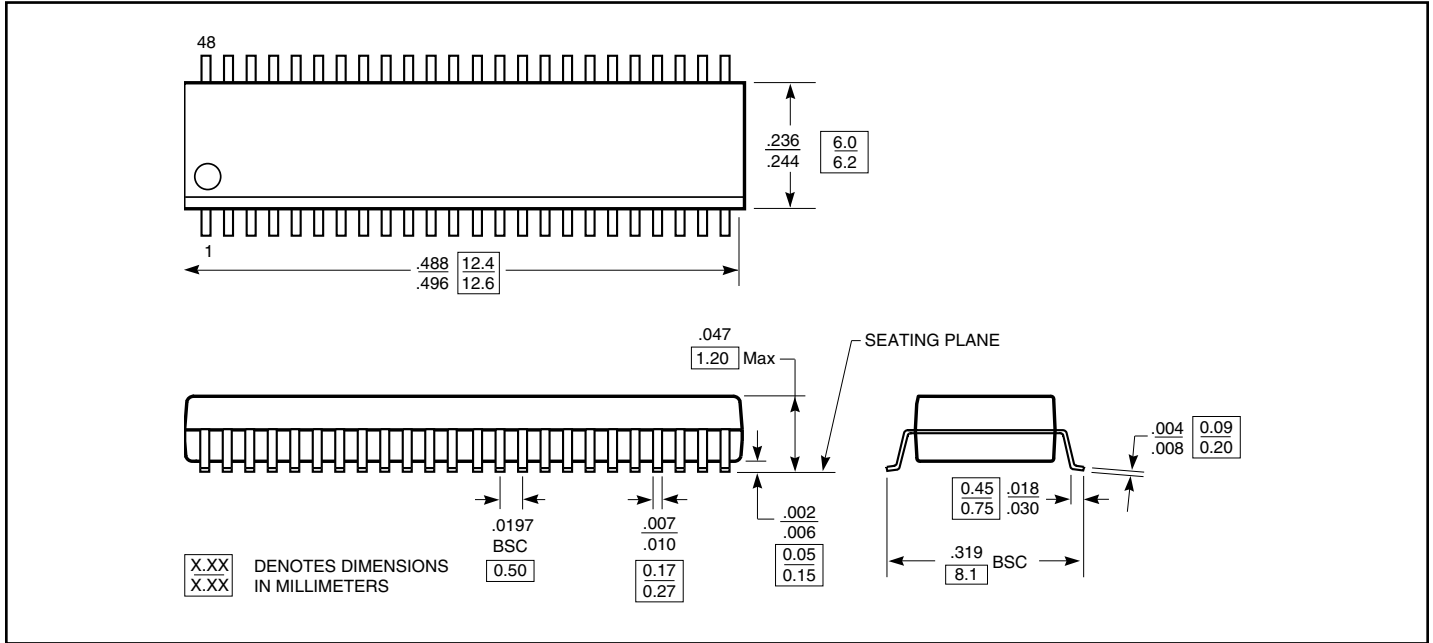
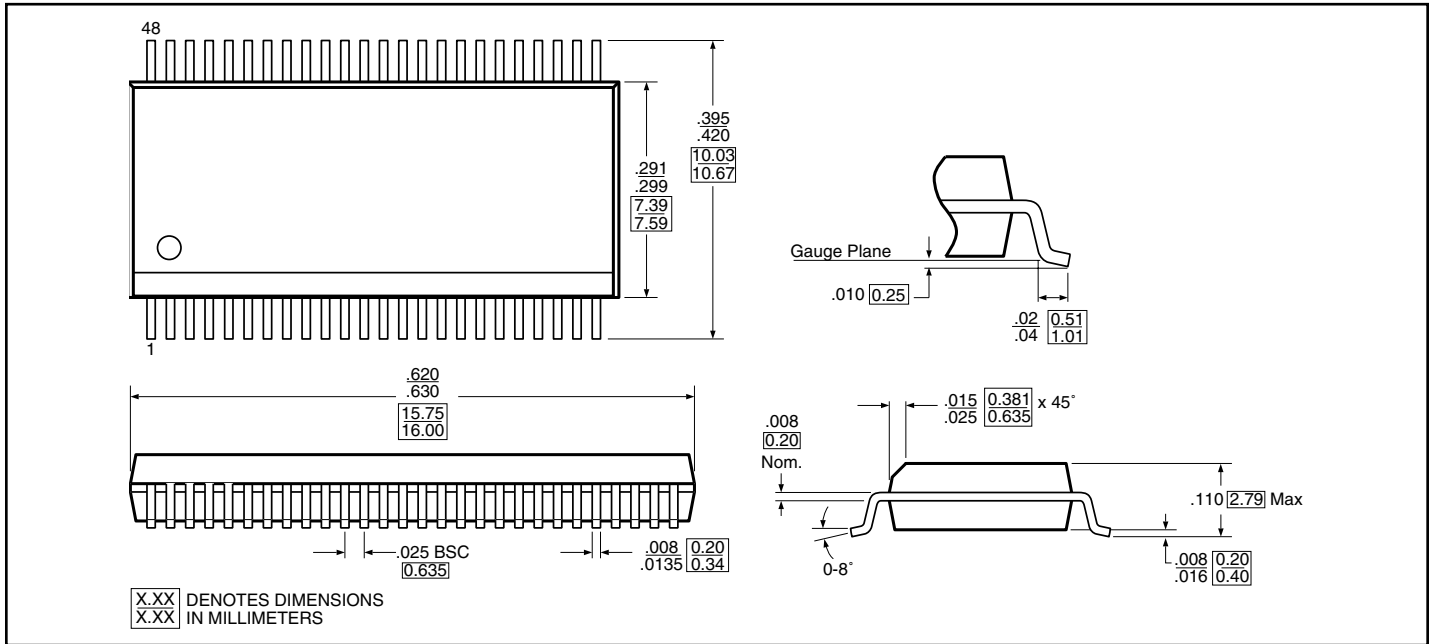
Packaging Mechanical: 48-pin TSSOP (A)

Packaging Mechanical: 48-pin SSOP (V)

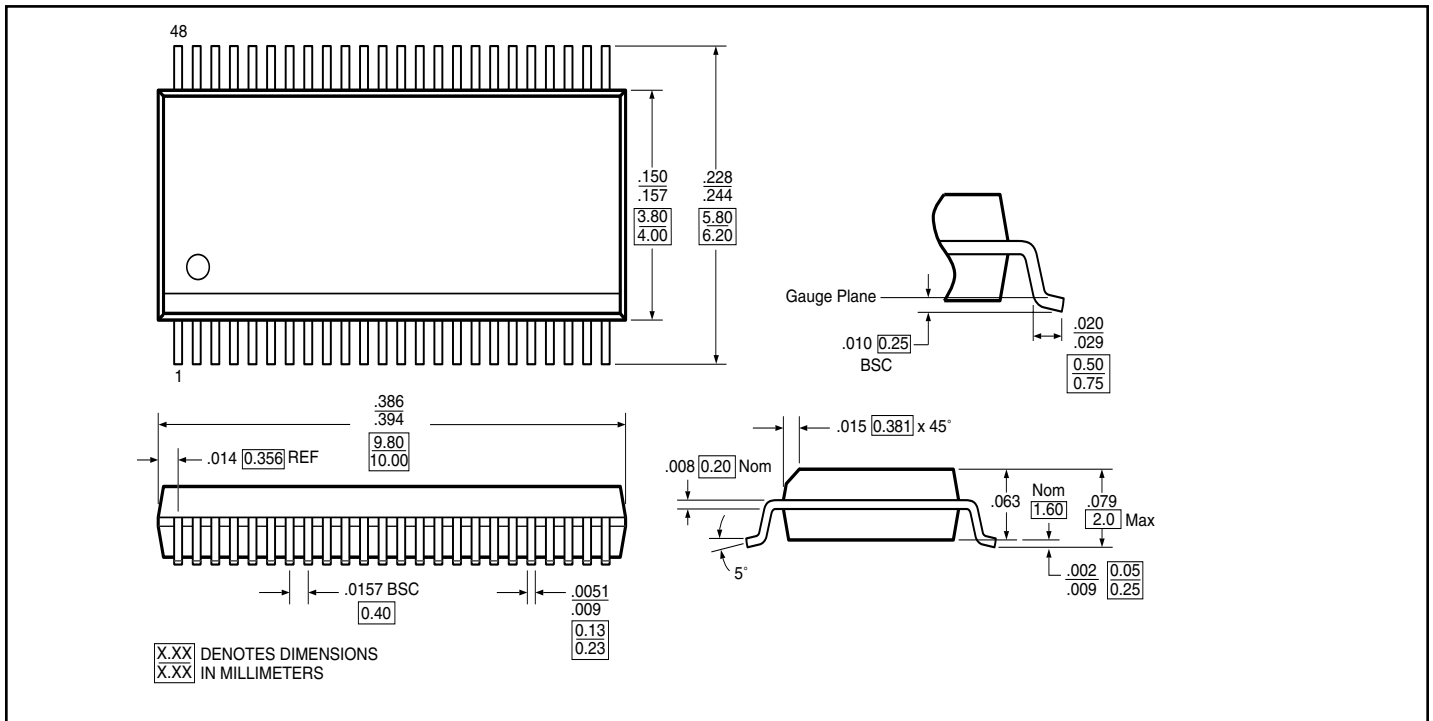
Packaging Mechanical: 48-pin BQSOP (B)



Ordering Information

Ordering Code	Package Code	Package Description
PI5C16244A	A	48-pin TSSOP
PI5C16244AE	A	Pb-free & Green, 48-pin TSSOP
PI5C16244B	B	48-pin BQSOP
PI5C16244BE	B	Pb-free & Green, 48-pin BQSOP
PI5C16244V	V	48-pin SSOP
PI5C16244VE	V	Pb-free & Green, 48-pin SSOP

Notes:

- Thermal characteristics can be found on the company web site at www.pericom.com/packaging/
- E = Pb-free and Green
- X suffix = Tape/Reel