



3.3V CMOS QUADRUPLE 2-LINE TO 1-LINE DATA SELECTOR/MULTIPLEXER, 5 VOLT TOLERANT I/O

IDT74LVC157A

FEATURES:

- 0.5 MICRON CMOS Technology
- ESD > 2000V per MIL-STD-883, Method 3015; > 200V using machine model (C = 200pF, R = 0)
- $V_{CC} = 3.3V \pm 0.3V$, Normal Range
- $V_{CC} = 2.7V$ to $3.6V$, Extended Range
- CMOS power levels ($0.4\mu W$ typ. static)
- Rail-to-Rail output swing for increased noise margin
- All inputs, outputs, and I/Os are 5V tolerant
- Supports hot insertion
- Available in QSOP, SOIC, SSOP, and TSSOP packages

DRIVE FEATURES:

- High Output Drivers: $\pm 24mA$
- Reduced system switching noise

DESCRIPTION:

This quadruple 2-line to 1-line data selector/multiplexer is built using advanced dual metal CMOS technology. The LVC157A features a common strobe (\bar{G}) input. When the strobe is high, all outputs are low. When the strobe is low, a 4-bit word is selected from one of two sources and is routed to the four outputs. The device provides true data.

Inputs can be driven from either 3.3V or 5V devices. This feature allows the use of this device as a translator in a mixed 3.3V/5V supply system.

The LVC157A has been designed with a $\pm 24mA$ output driver. This driver is capable of driving a moderate to heavy load while maintaining speed performance.

APPLICATIONS:

- 5V and 3.3V mixed voltage systems
- Data communication and telecommunication systems

FUNCTIONAL BLOCK DIAGRAM

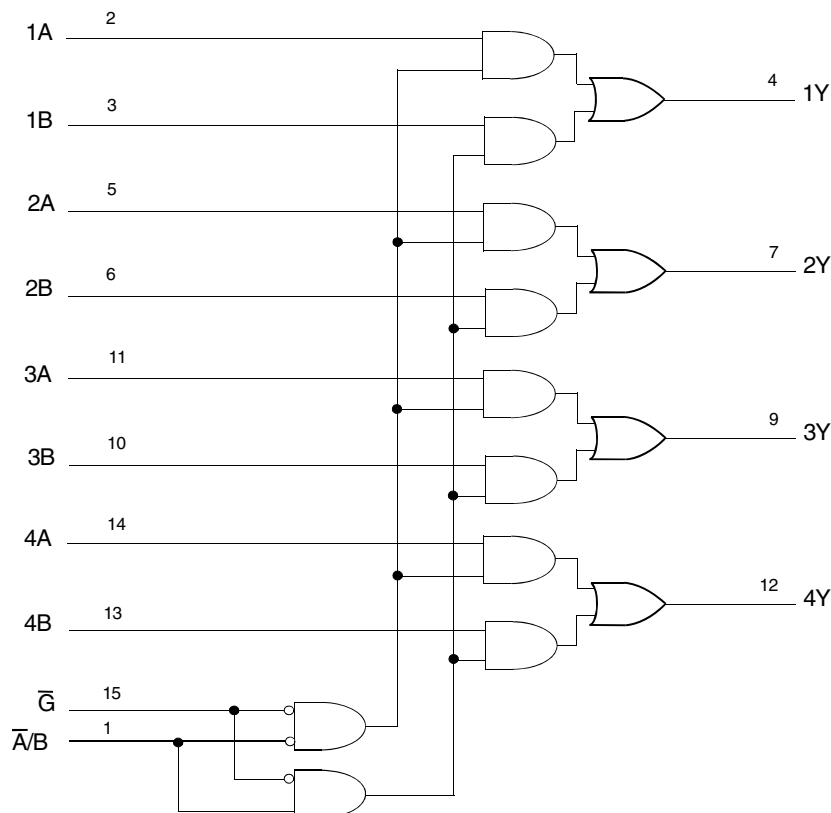

The IDT logo is a registered trademark of Integrated Device Technology, Inc.

INDUSTRIAL TEMPERATURE RANGE

FEBRUARY 2000

PIN CONFIGURATION

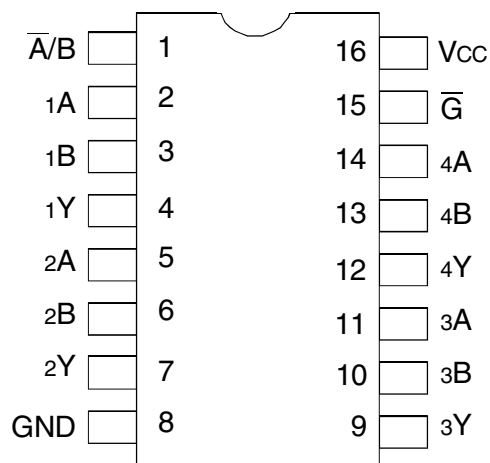

QSOP/ SOIC/ SSOP/ TSSOP
TOP VIEW

ABSOLUTE MAXIMUM RATINGS⁽¹⁾

Symbol	Description	Max	Unit
V _{TERM}	Terminal Voltage with Respect to GND	-0.5 to +6.5	V
T _{STG}	Storage Temperature	-65 to +150	°C
I _{OUT}	DC Output Current	-50 to +50	mA
I _{IK} I _{OK}	Continuous Clamp Current, V _I < 0 or V _O < 0	-50	mA
I _{CC} I _{SS}	Continuous Current through each V _{CC} or GND	±100	mA

NOTE:

1. Stresses greater than those listed under ABSOLUTE MAXIMUM RATINGS may cause permanent damage to the device. This is a stress rating only and functional operation of the device at these or any other conditions above those indicated in the operational sections of this specification is not implied. Exposure to absolute maximum rating conditions for extended periods may affect reliability.

CAPACITANCE (T_A = +25°C, F = 1.0MHz)

Symbol	Parameter ⁽¹⁾	Conditions	Typ.	Max.	Unit
C _{IN}	Input Capacitance	V _{IN} = 0V	4.5	6	pF
C _{OUT}	Output Capacitance	V _{OUT} = 0V	5.5	8	pF
C _{I/O}	I/O Port Capacitance	V _{IN} = 0V	6.5	8	pF

NOTE:

1. As applicable to the device type.

PIN DESCRIPTION

Pin Names	Description
A/B	Select Input (Active LOW)
G-bar	Common Strobe Input (Active LOW)
xY	Data Outputs
xA, xB	Data Inputs

FUNCTION TABLE⁽¹⁾

Inputs				Outputs
G-bar	A/B	xA	xB	xY
H	X	X	X	L
L	L	L	X	L
L	L	H	X	H
L	H	X	L	L
L	H	X	H	H

NOTE:

1. H = HIGH Voltage Level
L = LOW Voltage Level
X = Don't Care

DC ELECTRICAL CHARACTERISTICS OVER OPERATING RANGE

Following Conditions Apply Unless Otherwise Specified:

Operating Condition: $T_A = -40^{\circ}\text{C}$ to $+85^{\circ}\text{C}$

Symbol	Parameter	Test Conditions		Min.	Typ. ⁽¹⁾	Max.	Unit
V _{IH}	Input HIGH Voltage Level	V _{CC} = 2.3V to 2.7V		1.7	—	—	V
		V _{CC} = 2.7V to 3.6V		2	—	—	
V _{IL}	Input LOW Voltage Level	V _{CC} = 2.3V to 2.7V		—	—	0.7	V
		V _{CC} = 2.7V to 3.6V		—	—	0.8	
I _{IH} I _{IL}	Input Leakage Current	V _{CC} = 3.6V	V _I = 0 to 5.5V	—	—	±5	μA
I _{OZH} I _{OZL}	High Impedance Output Current (3-State Output pins)	V _{CC} = 3.6V	V _O = 0 to 5.5V	—	—	±10	μA
I _{OFF}	Input/Output Power Off Leakage	V _{CC} = 0V, V _{IN} or V _O ≤ 5.5V		—	—	±50	μA
V _{IK}	Clamp Diode Voltage	V _{CC} = 2.3V, I _{IN} = -18mA		—	-0.7	-1.2	V
V _H	Input Hysteresis	V _{CC} = 3.3V		—	100	—	mV
I _{CCL} I _{CCH} I _{CCZ}	Quiescent Power Supply Current	V _{CC} = 3.6V, V _{IN} = GND or V _{CC}		—	—	10	μA
ΔI _{CC}	Quiescent Power Supply Current Variation	One input at V _{CC} - 0.6V, other inputs at V _{CC} or GND		—	—	500	μA

NOTE:

1. Typical values are at V_{CC} = 3.3V, +25°C ambient.

OUTPUT DRIVE CHARACTERISTICS

Symbol	Parameter	Test Conditions ⁽¹⁾		Min.	Max.	Unit
V _{OH}	Output HIGH Voltage	V _{CC} = 2.3V to 3.6V	I _{OH} = -0.1mA	V _{CC} - 0.2	—	V
		V _{CC} = 2.3V	I _{OH} = -6mA	2	—	
		V _{CC} = 2.3V	I _{OH} = -12mA	1.7	—	
		V _{CC} = 2.7V		2.2	—	
		V _{CC} = 3V		2.4	—	
		V _{CC} = 3V	I _{OH} = -24mA	2.2	—	
V _{OL}	Output LOW Voltage	V _{CC} = 2.3V to 3.6V	I _{OL} = 0.1mA	—	0.2	V
		V _{CC} = 2.3V	I _{OL} = 6mA	—	0.4	
			I _{OL} = 12mA	—	0.7	
		V _{CC} = 2.7V	I _{OL} = 12mA	—	0.4	
		V _{CC} = 3V	I _{OL} = 24mA	—	0.55	

NOTE:

1. V_{IH} and V_{IL} must be within the min. or max. range shown in the DC ELECTRICAL CHARACTERISTICS OVER OPERATING RANGE table for the appropriate V_{CC} range. T_A = -40°C to +85°C.

OPERATING CHARACTERISTICS, $V_{CC} = 3.3V \pm 0.3V$, $T_A = 25^\circ C$

Symbol	Parameter	Test Conditions	Typical	Unit
CPD	Power Dissipation Capacitance	$C_L = 0pF$, $f = 10MHz$	16	pF

SWITCHING CHARACTERISTICS⁽¹⁾

Symbol	Parameter	$V_{CC} = 2.7V$		$V_{CC} = 3.3V \pm 0.3V$		Unit
		Min.	Max.	Min.	Max.	
t_{PLH} t_{PHL}	Propagation Delay xA or xB to xY	—	5.9	1	5.2	ns
t_{PLH} t_{PHL}	Propagation Delay \bar{A}/B to xY	—	8.1	1	6.8	ns
t_{PLH} t_{PHL}	Propagation Delay \bar{G} to xY	—	7.8	1	6.5	ns
$t_{sk(0)}$	Output Skew ⁽²⁾	—	—	—	1	ns

NOTES:

1. See TEST CIRCUITS AND WAVEFORMS. $T_A = -40^\circ C$ to $+85^\circ C$.
2. Skew between any two outputs of the same package and switching in the same direction.

TEST CIRCUITS AND WAVEFORMS
TEST CONDITIONS

Symbol	V _{CC} ⁽¹⁾ = 2.5V±0.2V	V _{CC} ⁽²⁾ = 3.3V±0.3V & 2.7V	Unit
V _{LOAD}	2 x V _{CC}	6	V
V _{IH}	V _{CC}	2.7	V
V _T	V _{CC} / 2	1.5	V
V _{LZ}	150	300	mV
V _{HZ}	150	300	mV
C _L	30	50	pF

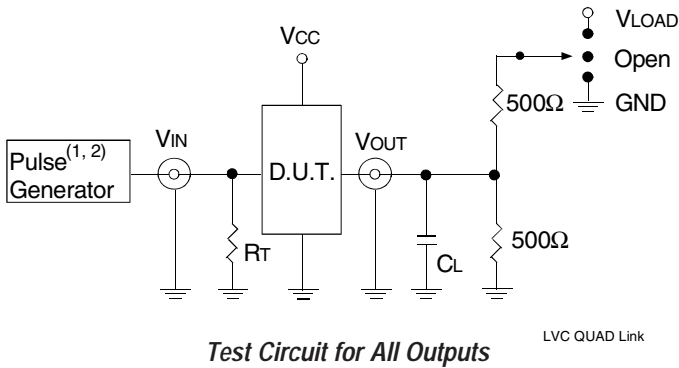

DEFINITIONS:

C_L = Load capacitance: includes jig and probe capacitance.
R_T = Termination resistance: should be equal to Z_{out} of the Pulse Generator.

NOTES:

1. Pulse Generator for All Pulses: Rate ≤ 10MHz; t_r ≤ 2ns; t_r ≤ 2ns.
2. Pulse Generator for All Pulses: Rate ≤ 10MHz; t_r ≤ 2.5ns; t_r ≤ 2.5ns.

SWITCH POSITION

Test	Switch
Open Drain Disable Low Enable Low	V _{LOAD}
Disable High Enable High	GND
All Other Tests	Open

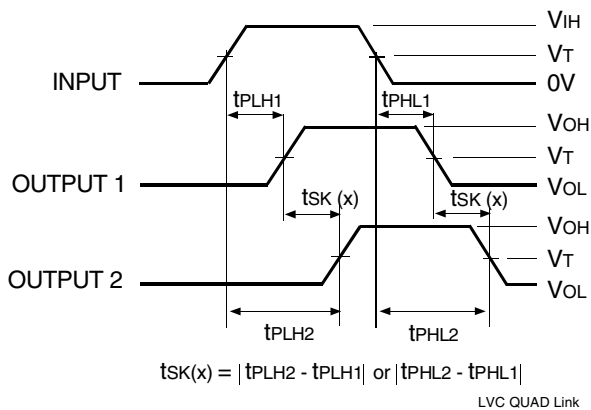

NOTES:

1. For t_{sk}(o) OUTPUT1 and OUTPUT2 are any two outputs.
2. For t_{sk}(b) OUTPUT1 and OUTPUT2 are in the same bank.

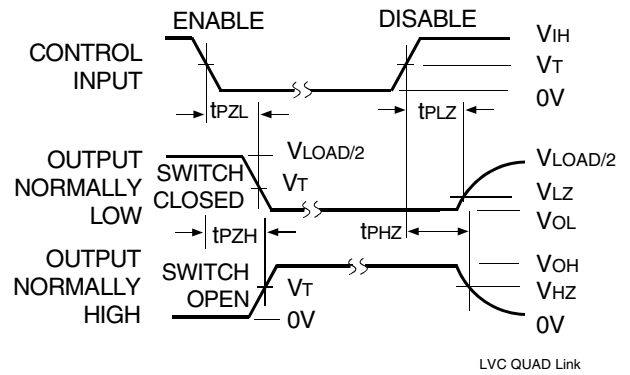
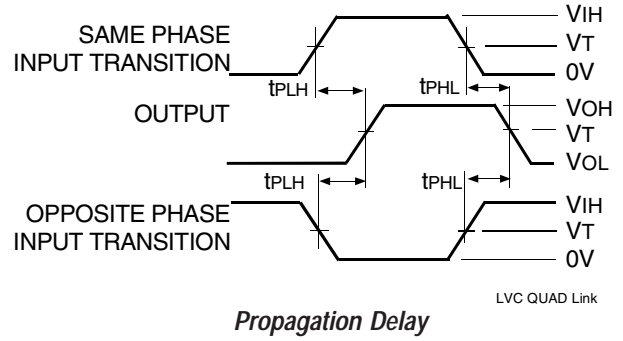

NOTE:

1. Diagram shown for input Control Enable-LOW and input Control Disable-HIGH.

Enable and Disable Times

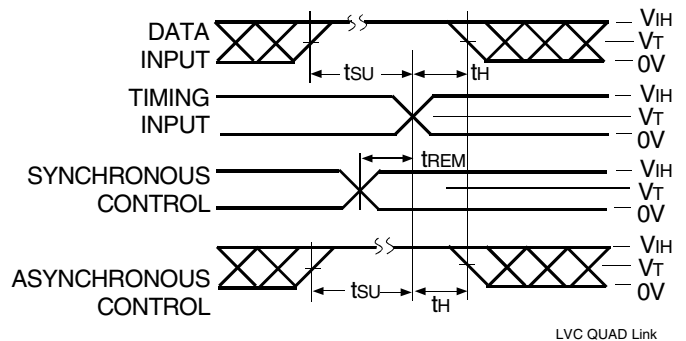

Set-up, Hold, and Release Times

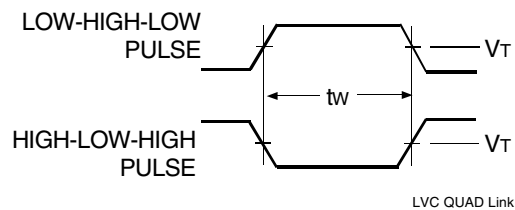

ORDERING INFORMATION

IDT XX LVC XXXX XX
Temp. Range Device Type Package

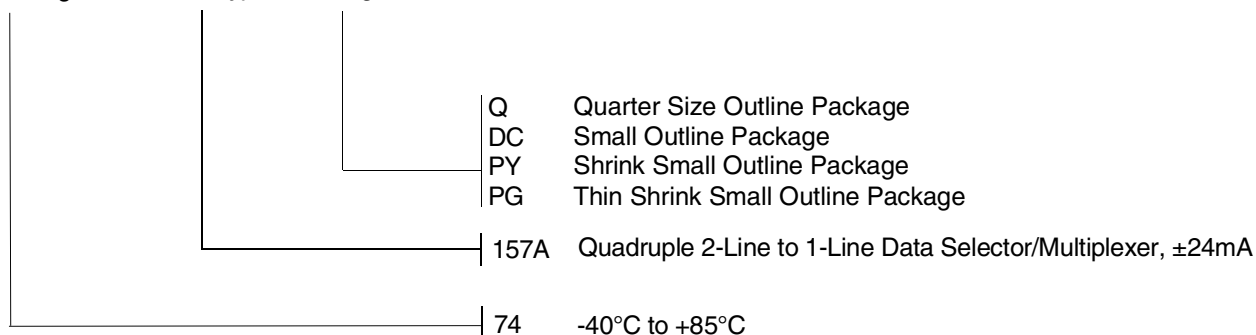

CORPORATE HEADQUARTERS
6024 Silver Creek Valley Road
San Jose, CA 95138

for SALES:
800-345-7015 or 408-284-8200
fax: 408-284-2775
www.idt.com

for Tech Support:
logichelp@idt.com