

SN74ALVC16652

16-BIT BUS TRANSCEIVER AND REGISTER WITH 3-STATE OUTPUTS

SCAS266 - JANUARY 1993 - REVISED MARCH 1994

- Member of the Texas Instruments *Widebus™* Family
- EPIC™ (Enhanced-Performance Implanted CMOS) Submicron Process
- Designed to Facilitate Incident-Wave Switching for Line Impedances of 50 Ω or Greater
- Typical V_{OLP} (Output Ground Bounce) < 0.8 V at $V_{CC} = 3.3$ V, $T_A = 25^\circ\text{C}$
- Typical V_{OHV} (Output V_{OH} Undershoot) > 2 V at $V_{CC} = 3.3$ V, $T_A = 25^\circ\text{C}$
- Bus-Hold On Data Inputs Eliminates the Need for External Pullup/Pulldown Resistors
- Package Options Include Plastic 300-mil Shrink Small-Outline (DL) and Thin Shrink Small-Outline (DGG) Packages

description

This 16-bit bus transceiver and register is designed for 2.7-V to 3.6-V V_{CC} operation.

The SN74ALVC16652 consists of D-type flip-flops and control circuitry arranged for multiplexed transmission of data directly from the data bus or from the internal storage registers. The device can be used as two 8-bit transceivers or one 16-bit transceiver.

Complementary output-enable (OEAB and OEBA) inputs are provided to control the transceiver functions. Select-control (SAB and SBA) inputs are provided to select whether real-time or stored data is transferred. A low input level selects real-time data, and a high input level selects stored data. The circuitry used for select control eliminates the typical decoding glitch that occurs in a multiplexer during the transition between stored and real-time data. Figure 1 illustrates the four fundamental bus-management functions that can be performed with the SN74ALVC16652.

Data on the A or B bus, or both, can be stored in the internal D flip-flops by low-to-high transitions at the appropriate clock (CLKAB or CLKBA) inputs regardless of the levels on the select-control or output-enable inputs. When SAB and SBA are in the real-time transfer mode, it is also possible to store data without using the internal D-type flip-flops by simultaneously enabling OEAB and OEBA. In this configuration, each output reinforces its input. Thus, when all other data sources to the two sets of bus line are at high impedance, each set of bus lines remains at its last level configuration.

The SN74ALVC16652 is available in TI's shrink small-outline (DL) and thin shrink small-outline (DGG) packages, which provide twice the I/O pin count and functionality of standard small-outline packages in the same printed-circuit-board area.

The SN74ALVC16652 is characterized for operation from -40°C to 85°C .

DGG OR DL PACKAGE
(TOP VIEW)

1OEAB	1	56	1OEBA
1CLKAB	2	55	1CLKBA
1SAB	3	54	1SBA
GND	4	53	GND
1A1	5	52	1B1
1A2	6	51	1B2
V_{CC}	7	50	V_{CC}
1A3	8	49	1B3
1A4	9	48	1B4
1A5	10	47	1B5
GND	11	46	GND
1A6	12	45	1B6
1A7	13	44	1B7
1A8	14	43	1B8
2A1	15	42	2B1
2A2	16	41	2B2
2A3	17	40	2B3
GND	18	39	GND
2A4	19	38	2B4
2A5	20	37	2B5
2A6	21	36	2B6
V_{CC}	22	35	V_{CC}
2A7	23	34	2B7
2A8	24	33	2B8
GND	25	32	GND
2SAB	26	31	2SBA
2CLKAB	27	30	2CLKBA
2OEAB	28	29	2OEBA

EPIC and Widebus are trademarks of Texas Instruments Incorporated.

PRODUCT PREVIEW Information concerns products in the formative or design phase of development. Characteristic data and other specifications are design goals. Texas Instruments reserves the right to change or discontinue these products without notice.



POST OFFICE BOX 655303 • DALLAS, TEXAS 75265

Copyright © 1994, Texas Instruments Incorporated

PRODUCT PREVIEW

SN74ALVC16652
16-BIT BUS TRANSCEIVER AND REGISTER
WITH 3-STATE OUTPUTS

SCAS286 - JANUARY 1993 - REVISED MARCH 1994

FUNCTION TABLE

INPUTS						DATA I/O†		OPERATION OR FUNCTION
OEAB	OEBA	CLKAB	CLKBA	SAB	SBA	A1 THRU A8	B1 THRU B8	
L	H	H or L	H or L	X	X	Input	Input	Isolation
L	H	↑	↑	X	X	Input	Input	Store A and B data
X	H	↑	H or L	X	X	Input	Unspecified‡	Store A, hold B
H	H	↑	↑	X‡	X	Input	Output	Store A in both registers
L	X	H or L	↑	X	X	Unspecified‡	Input	Hold A, store B
L	L	↑	↑	X	X‡	Output	Input	Store B in both registers
L	L	X	X	X	L	Output	Input	Real-time B data to A bus
L	L	X	H or L	X	H	Output	Input	Stored B data to A bus
H	H	X	X	L	X	Input	Output	Real-time A data to B bus
H	H	H or L	X	H	X	Input	Output	Stored A data to B bus
H	L	H or L	H or L	H	H	Output	Output	Stored A data to B bus and stored B data to A bus

† The data output functions may be enabled or disabled by a variety of level combinations at the OEAB or OEBA inputs. Data input functions are always enabled; i.e., data at the bus pins is stored on every low-to-high transition on the clock inputs.

‡ Select control = L; clocks can occur simultaneously.

Select control = H; clocks must be staggered in order to load both registers.

PRODUCT PREVIEW



POST OFFICE BOX 655303 • DALLAS, TEXAS 75265

SN74ALVC1652
16-BIT BUS TRANSCEIVER AND REGISTER
WITH 3-STATE OUTPUTS

SCAS266 - JANUARY 1993 - REVISED MARCH 1994

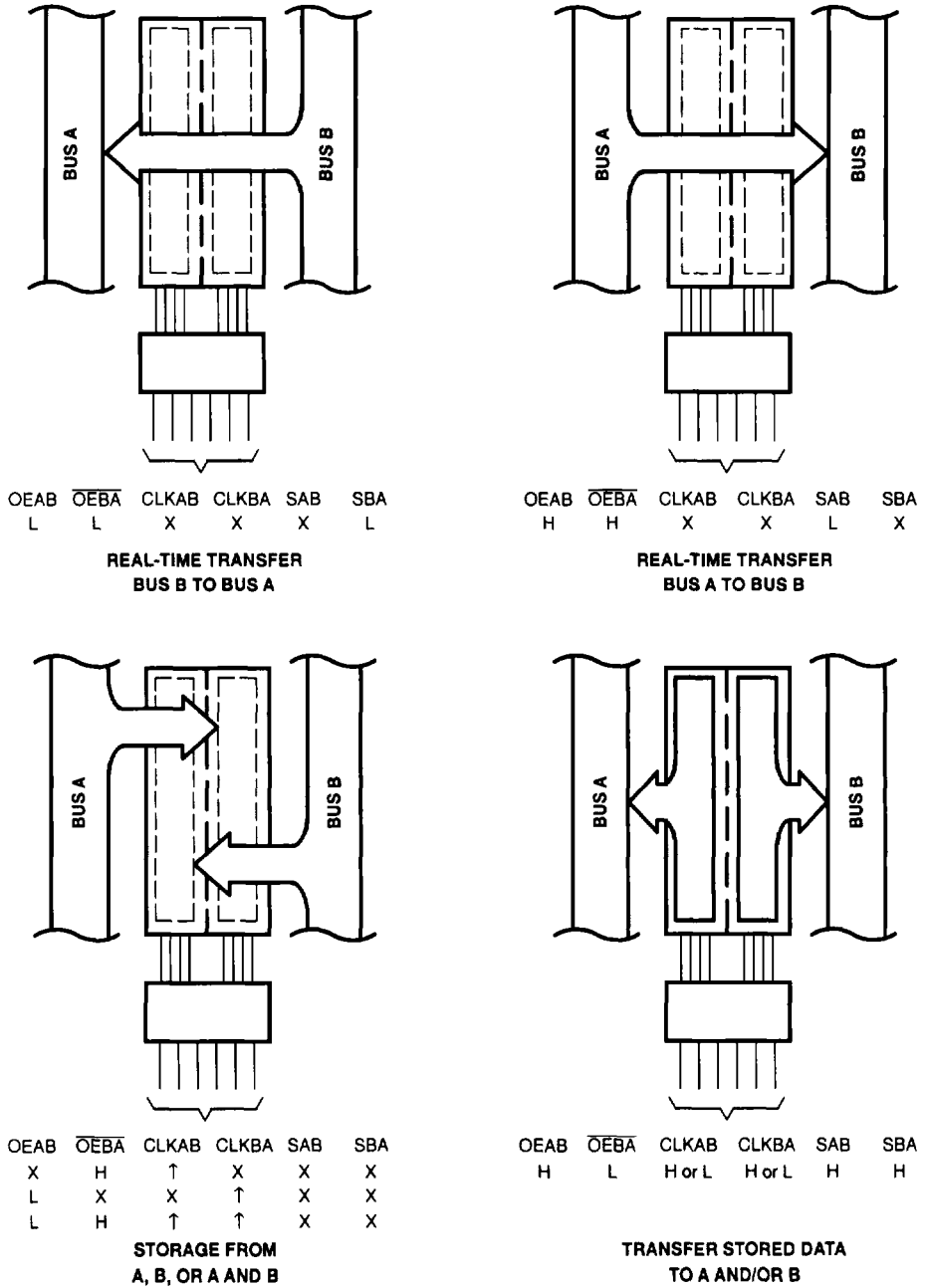
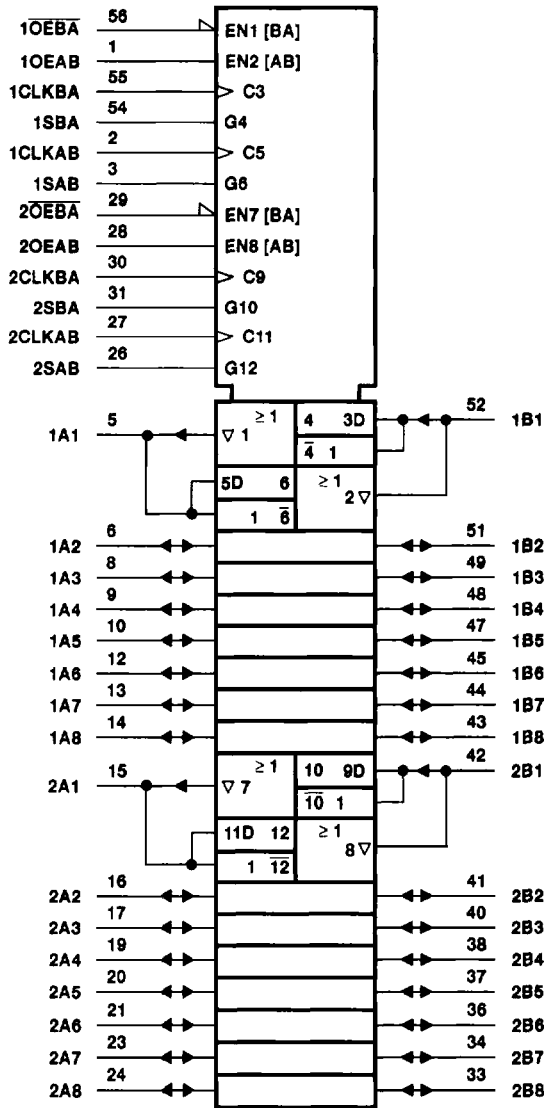

Figure 1. Bus-Management Functions

SN74ALVC16652
16-BIT BUS TRANSCEIVER AND REGISTER
WITH 3-STATE OUTPUTS

SCAS266 - JANUARY 1993 - REVISED MARCH 1994

logic symbol†



† This symbol is in accordance with ANSI/IEEE Std 91-1984 and IEC Publication 617-12.

PRODUCT PREVIEW



POST OFFICE BOX 855303 • DALLAS, TEXAS 75285

SN74ALVC16652
16-BIT BUS TRANSCEIVER AND REGISTER
WITH 3-STATE OUTPUTS

SCAS266 - JANUARY 1993 - REVISED MARCH 1994

logic diagram (positive logic)

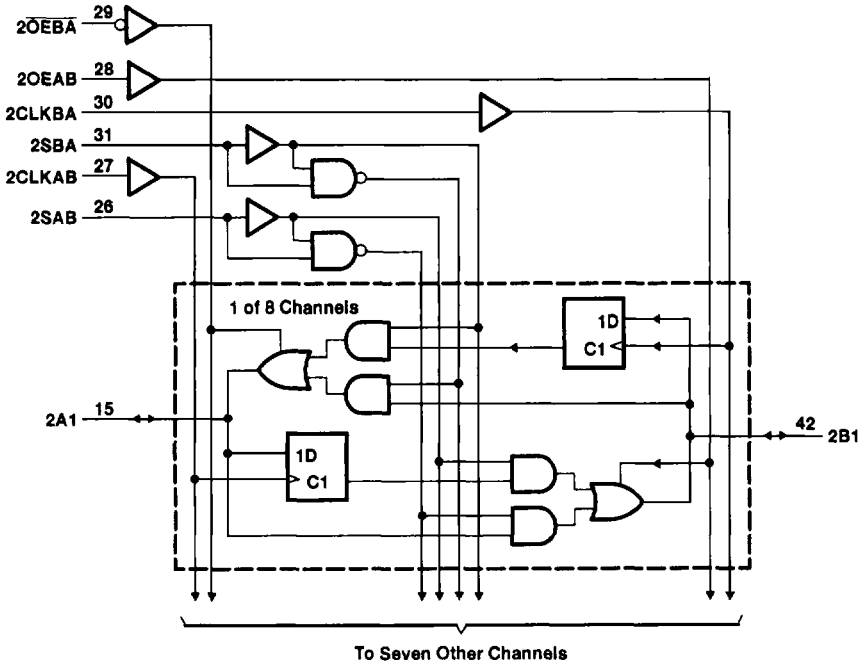
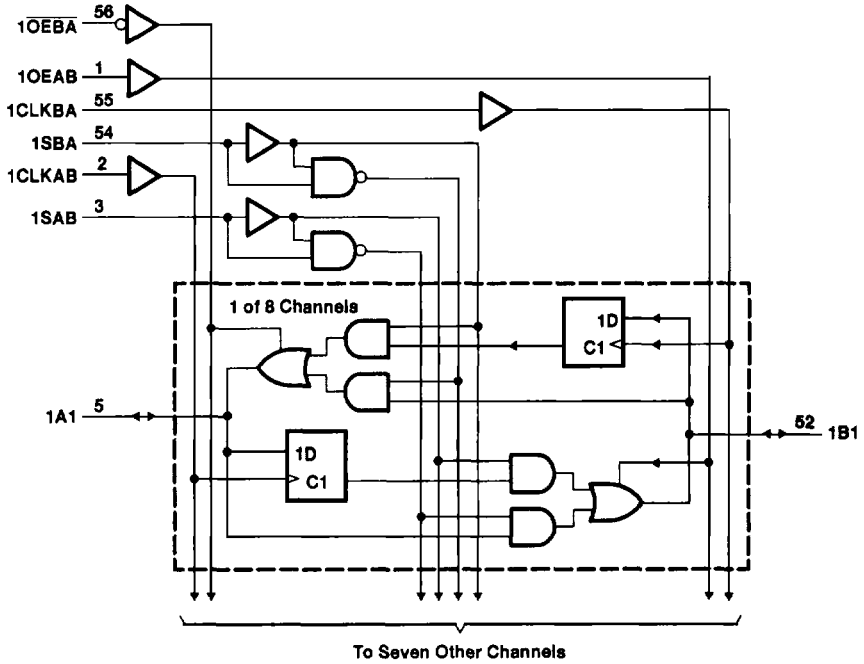

PRODUCT PREVIEW



POST OFFICE BOX 655303 • DALLAS, TEXAS 75265

SN74ALVC16652

16-BIT BUS TRANSCEIVER AND REGISTER

WITH 3-STATE OUTPUTS

SCAS266 - JANUARY 1993 - REVISED MARCH 1994

absolute maximum ratings over operating free-air temperature range (unless otherwise noted)†

Supply voltage range, V_{CC}	-0.5 V to 4.6 V
Input voltage range, V_I (except I/O ports) (see Note 1)	-0.5 V to 4.6 V
Input voltage range, V_I (I/O ports) (see Notes 1 and 2)	-0.5 V to $V_{CC} + 0.5$ V
Output voltage range, V_O (see Notes 1 and 2)	-0.5 V to $V_{CC} + 0.5$ V
Input clamp current, I_{IK} ($V_I < 0$)	-50 mA
Output clamp current, I_{OK} ($V_O < 0$ or $V_O > V_{CC}$)	±50 mA
Continuous output current, I_O ($V_O = 0$ to V_{CC})	±50 mA
Continuous current through V_{CC} or GND	±100 mA
Maximum power dissipation at $T_A = 55^\circ\text{C}$ (in still air) (see Note 3): DGG package	1 W
DL package	1.4 W
Storage temperature range	-65°C to 150°C

† Stresses beyond those listed under "absolute maximum ratings" may cause permanent damage to the device. These are stress ratings only, and functional operation of the device at these or any other conditions beyond those indicated under "recommended operating conditions" is not implied. Exposure to absolute-maximum-rated conditions for extended periods may affect device reliability.

- NOTES: 1. The input and output voltage ratings may be exceeded if the input and output clamp-current ratings are observed.
 2. This value is limited to 4.6 V maximum.
 3. The maximum package power dissipation is calculated using a junction temperature of 150°C and a board trace length of 750 mills.
 For more information, refer to the *Package Thermal Considerations* application note.

recommended operating conditions

		MIN	MAX	UNIT
V_{CC}	Supply voltage	2.7	3.6	V
V_{IH}	High-level input voltage	$V_{CC} = 2.7$ V to 3.6 V		V
V_{IL}	Low-level input voltage	$V_{CC} = 2.7$ V to 3.6 V		V
V_I	Input voltage	0	V_{CC}	V
V_O	Output voltage	0	V_{CC}	V
I_{OH}	High-level output current	$V_{CC} = 2.7$ V		mA
		$V_{CC} = 3$ V		
I_{OL}	Low-level output current	$V_{CC} = 2.7$ V		mA
		$V_{CC} = 3$ V		
$\Delta t/\Delta v$	Input transition rise or fall rate	0	10	ns/V
T_A	Operating free-air temperature	-40	85	°C

PRODUCT PREVIEW



POST OFFICE BOX 655303 • DALLAS, TEXAS 75285

SN74ALVC16652
16-BIT BUS TRANSCEIVER AND REGISTER
WITH 3-STATE OUTPUTS

SCAS266 - JANUARY 1993 - REVISED MARCH 1994

electrical characteristics over recommended operating free-air temperature range (unless otherwise noted)

PARAMETER		TEST CONDITIONS	V _{CC} [†]	MIN	MAX	UNIT
V _{OH}		I _{OH} = -100 μA	MIN to MAX	V _{CC} - 0.2		V
		I _{OH} = -12 mA	2.7 V	2.2		
		I _{OH} = -24 mA	3 V	2.4		
		I _{OH} = -24 mA	3 V	2		
V _{OL}		I _{OL} = 100 μA	MIN to MAX	0.2		V
		I _{OL} = 12 mA	2.7 V	0.4		
		I _{OL} = 24 mA	3 V	0.55		
I _I		V _I = V _{CC} or GND	3.6 V	±5		μA
I _I (hold)	Data I/Os	V _I = 0.8 V	3 V	75		μA
		V _I = 2 V		-75		
I _{OZ} [‡]		V _O = V _{CC} or GND	3.6 V	±10		μA
I _{CC}		V _I = V _{CC} or GND, I _O = 0	3.6 V	40		μA
ΔI _{CC}		V _{CC} = 3 V to 3.6 V, One input at V _{CC} - 0.6 V, Other inputs at V _{CC} or GND		750		μA
C _i	Control inputs	V _I = V _{CC} or GND	3.3 V			pF
C _{io}	A or B ports	V _O = V _{CC} or GND	3.3 V			pF

[†] For conditions shown as MIN or MAX, use the appropriate values under recommended operating conditions.

[‡] For I/O ports, the parameter I_{OZ} includes the input leakage current.

PRODUCT PREVIEW

