

# TYPES SN5432, SN54LS32, SN54S32, SN7432, SN74LS32, SN74S32 QUADRUPLE 2-INPUT POSITIVE-OR GATES

REVISED DECEMBER 1983

- Package Options Include Both Plastic and Ceramic Chip Carriers in Addition to Plastic and Ceramic DIPs
- Dependable Texas Instruments Quality and Reliability

SN5432, SN54LS32, SN54S32 . . . J OR W PACKAGE  
SN7432 . . . J OR N PACKAGE  
SN74LS32, SN74S32 . . . D, J or N PACKAGE

(TOP VIEW)

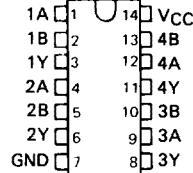

SN54LS32, SN54S32 . . . FK PACKAGE  
SN74LS32, SN74S32 . . . FN PACKAGE

(TOP VIEW)

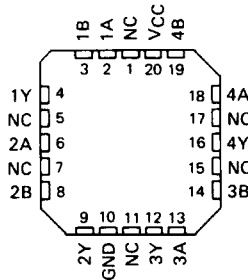

NC - No internal connection

## description

These devices contain four independent 2-input OR gates.

The SN5432, SN54LS32 and SN54S32 are characterized for operation over the full military range of  $-55^{\circ}\text{C}$  to  $125^{\circ}\text{C}$ . The SN7432, SN74LS32 and SN74S32 are characterized for operation from  $0^{\circ}\text{C}$  to  $70^{\circ}\text{C}$ .

## FUNCTION TABLE (each gate)

INPUTS		OUTPUT
A	B	Y
H	X	H
X	H	H
L	L	L

## logic diagram (each gate)



## positive logic

$$Y = A + B \text{ or } Y = \overline{\overline{A} \cdot \overline{B}}$$

3

TTL DEVICES

## PRODUCTION DATA

This document contains information current as of publication date. Products conform to specifications per the terms of Texas Instruments standard warranty. Production processing does not necessarily include testing of all parameters.

TEXAS  
INSTRUMENTS

POST OFFICE BOX 225012 • DALLAS, TEXAS 75265

# TYPES SN5432, SN54LS32, SN54S32, SN7432, SN74LS32, SN74S32 QUADRUPLE 2-INPUT POSITIVE-OR GATES

schematics (each gate)

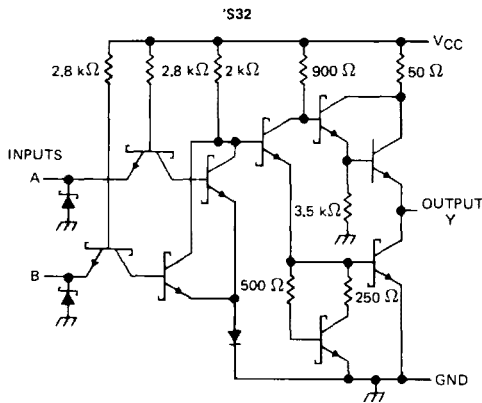
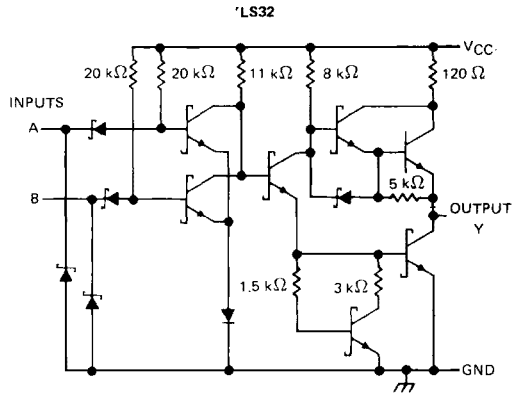
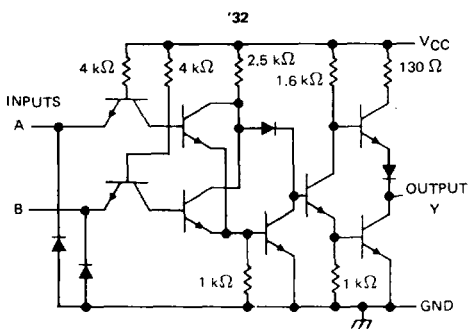

Resistor values shown are nominal.

absolute maximum ratings over operating free-air temperature range (unless otherwise noted)

Supply voltage, $V_{CC}$ (see Note 1)	7 V
Input voltage: '32, 'S32	5.5 V
'LS32	7 V
Operating free-air temperature: SN54'	-55°C to 125°C
SN74'	0°C to 70°C
Storage temperature range	-65°C to 150°C

NOTE 1: Voltage values are with respect to network ground terminal.

TTL DEVICES

# TYPES SN5432, SN7432 QUADRUPLE 2-INPUT POSITIVE-OR GATES

## recommended operating conditions

	SN5432			SN7432			UNIT
	MIN	NOM	MAX	MIN	NOM	MAX	
V <sub>CC</sub> Supply voltage	4.5	5	5.5	4.75	5	5.25	V
V <sub>IH</sub> High-level input voltage	2			2			V
V <sub>IL</sub> Low-level input voltage	0.8			0.8			V
I <sub>OH</sub> High-level output current	-0.8			-0.8			mA
I <sub>OL</sub> Low-level output current	16			16			mA
T <sub>A</sub> Operating free-air temperature	-55			0			70 °C

## electrical characteristics over recommended operating free-air temperature range (unless otherwise noted)

PARAMETER	TEST CONDITIONS †	SN5432			SN7432			UNIT
		MIN	TYP ‡	MAX	MIN	TYP ‡	MAX	
V <sub>IK</sub>	V <sub>CC</sub> = MIN, I <sub>I</sub> = -12 mA	-1.5			-1.5			V
V <sub>OH</sub>	V <sub>CC</sub> = MIN, V <sub>IH</sub> = 2 V, I <sub>OH</sub> = -0.8 mA	2.4	3.4		2.4	3.4	V	
V <sub>OL</sub>	V <sub>CC</sub> = MIN, V <sub>IL</sub> = 0.8 V, I <sub>OL</sub> = 16 mA	0.2			0.2			V
I <sub>I</sub>	V <sub>CC</sub> = MAX, V <sub>I</sub> = 5.5 V	1			1			mA
I <sub>IH</sub>	V <sub>CC</sub> = MAX, V <sub>I</sub> = 2.4 V	40			40			μA
I <sub>IL</sub>	V <sub>CC</sub> = MAX, V <sub>I</sub> = 0.4 V	-1.6			-1.6			mA
I <sub>OS</sub> §	V <sub>CC</sub> = MAX	-20	-55		-18	-55	mA	
I <sub>CCH</sub>	V <sub>CC</sub> = MAX, See Note 2	15			15			22 mA
I <sub>CCL</sub>	V <sub>CC</sub> = MAX, V <sub>I</sub> = 0 V	23			23			38 mA

† For conditions shown as MIN or MAX, use the appropriate value specified under recommended operating conditions.

‡ All typical values are at V<sub>CC</sub> = 5 V, T<sub>A</sub> = 25°C.

§ Not more than one output should be shorted at a time.

NOTE 2: One input at 4.5 V, all others at GND.

## switching characteristics, V<sub>CC</sub> = 5 V, T<sub>A</sub> = 25°C (see note 3)

PARAMETER	FROM (INPUT)	TO (OUTPUT)	TEST CONDITIONS	MIN	TYP	MAX	UNIT
t <sub>PLH</sub>	A or B	Y	R <sub>L</sub> = 400 Ω, C <sub>L</sub> = 15 pF	10	15		ns
t <sub>PHL</sub>				14	22		ns

NOTE 3: See General Information Section for load circuits and voltage waveforms.

3

TTL DEVICES

# TYPES SN54LS32, SN74LS32 QUADRUPLE 2-INPUT POSITIVE-OR GATES

## recommended operating conditions

	SN54LS32			SN74LS32			UNIT		
	MIN	NOM	MAX	MIN	NOM	MAX			
$V_{CC}$ Supply voltage	4.5	5	5.5	4.75	5	5.25	V		
$V_{IH}$ High-level input voltage	2			2			V		
$V_{IL}$ Low-level input voltage	0.7			0.8			V		
$I_{OH}$ High-level output current	-0.4			-0.4			mA		
$I_{OL}$ Low-level output current	4			8			mA		
$T_A$ Operating free-air temperature	-55			125			0	70	°C

## electrical characteristics over recommended operating free-air temperature range (unless otherwise noted)

PARAMETER	TEST CONDITIONS †	SN54LS32		SN74LS32		UNIT
		MIN	TYP ‡	MAX	MIN	
$V_{IK}$	$V_{CC} = \text{MIN}$ , $I_I = -18 \text{ mA}$	-1.5		-1.5		V
$V_{OH}$	$V_{CC} = \text{MIN}$ , $V_{IH} = 2 \text{ V}$ , $I_{OH} = -0.4 \text{ mA}$	2.5	3.4	2.7	3.4	V
$V_{OL}$	$V_{CC} = \text{MIN}$ , $V_{IL} = \text{MAX}$ , $I_{OL} = 4 \text{ mA}$	0.25		0.4		V
	$V_{CC} = \text{MIN}$ , $V_{IL} = \text{MAX}$ , $I_{OL} = 8 \text{ mA}$			0.35		
$I_I$	$V_{CC} = \text{MAX}$ , $V_I = 7 \text{ V}$	0.1		0.1		mA
$I_{IH}$	$V_{CC} = \text{MAX}$ , $V_I = 2.7 \text{ V}$	20		20		µA
$I_{IL}$	$V_{CC} = \text{MAX}$ , $V_I = 0.4 \text{ V}$	-0.4		-0.4		mA
$I_{OS} §$	$V_{CC} = \text{MAX}$	-20	-100	-20	-100	mA
$I_{CCH}$	$V_{CC} = \text{MAX}$ , See Note 2	3.1		6.2		mA
$I_{CCL}$	$V_{CC} = \text{MAX}$ , $V_I = 0 \text{ V}$	4.9		9.8		mA

† For conditions shown as MIN or MAX, use the appropriate value specified under recommended operating conditions.

‡ All typical values are at  $V_{CC} = 5 \text{ V}$ ,  $T_A = 25^\circ\text{C}$ .

§ Not more than one output should be shorted at a time and the duration of the short-circuit should not exceed one second.

NOTE 2: One input at 4.5 V, all others at GND.

## switching characteristics, $V_{CC} = 5 \text{ V}$ , $T_A = 25^\circ\text{C}$ (see note 3)

PARAMETER	FROM (INPUT)	TO (OUTPUT)	TEST CONDITIONS	MIN	TYP	MAX	UNIT
$t_{PLH}$	A or B	Y	$R_L = 2 \text{ k}\Omega$ , $C_L = 15 \text{ pF}$	14		22	ns
$t_{PHL}$				14		22	ns

NOTE 3: See General Information Section for load circuits and voltage waveforms.

# TYPES SN54S32, SN74S32 QUADRUPLE 2-INPUT POSITIVE-OR GATES

## recommended operating conditions

	SN54S32			SN74S32			UNIT
	MIN	NOM	MAX	MIN	NOM	MAX	
V <sub>CC</sub> Supply voltage	4.5	5	5.5	4.75	5	5.25	V
V <sub>IH</sub> High-level input voltage	2			2			V
V <sub>IL</sub> Low-level input voltage			0.8			0.8	V
I <sub>OH</sub> High-level output current			-1			-1	mA
I <sub>OL</sub> Low-level output current			20			20	mA
T <sub>A</sub> Operating free-air temperature	-55		125	0		70	°C

## electrical characteristics over recommended operating free-air temperature range (unless otherwise noted)

PARAMETER	TEST CONDITIONS †	SN54S32			SN74S32			UNIT
		MIN	TYP ‡	MAX	MIN	TYP ‡	MAX	
V <sub>IK</sub>	V <sub>CC</sub> = MIN, I <sub>I</sub> = -18 mA			-1.2			-1.2	V
V <sub>OH</sub>	V <sub>CC</sub> = MIN, V <sub>IH</sub> = 2 V, I <sub>OH</sub> = -1 mA	2.5	3.4		2.7	3.4		V
V <sub>OL</sub>	V <sub>CC</sub> = MIN, V <sub>IL</sub> = 0.8 V, I <sub>OL</sub> = 20 mA			0.5			0.5	V
I <sub>I</sub>	V <sub>CC</sub> = MAX, V <sub>I</sub> = 5.5 V			1			1	mA
I <sub>IH</sub>	V <sub>CC</sub> = MAX, V <sub>I</sub> = 2.7 V			50			50	µA
I <sub>IL</sub>	V <sub>CC</sub> = MAX, V <sub>I</sub> = 0.5 V			-2			-2	mA
I <sub>OS</sub> §	V <sub>CC</sub> = MAX	-40		-100	-40		-100	mA
I <sub>CC</sub>	V <sub>CC</sub> = MAX, See Note 2		18	32		18	32	mA
I <sub>CCL</sub>	V <sub>CC</sub> = MAX, V <sub>I</sub> = 0 V		38	68		38	68	mA

† For conditions shown as MIN or MAX, use the appropriate value specified under recommended operating conditions.

‡ All typical values are at V<sub>CC</sub> = 5 V, T<sub>A</sub> = 25°C.

§ Not more than one output should be shorted at a time and the duration of the short-circuit should not exceed one second.

NOTE 2: One input at 4.5 V, all others at GND.

## switching characteristics, V<sub>CC</sub> = 5 V, T<sub>A</sub> = 25°C (see note 3)

PARAMETER	FROM (INPUT)	TO (OUTPUT)	TEST CONDITIONS		MIN	TYP	MAX	UNIT
t <sub>PLH</sub>	A or B	Y	R <sub>L</sub> = 280 Ω,	C <sub>L</sub> = 15 pF		4	7	ns
t <sub>PHL</sub>						4	7	ns
t <sub>PLH</sub>	A or B	Y	R <sub>L</sub> = 280 Ω,	C <sub>L</sub> = 50 pF		5		ns
t <sub>PHL</sub>						5		ns

NOTE 3: See General Information Section for load circuits and voltage waveforms.

3

TTL DEVICES