

## DM74AS874 Dual 4-Bit D-Type Edge-Triggered Flip-Flop

### General Description

These dual 4-bit inverting registers feature totem-pole TRI-STATE® outputs designed specifically for driving highly-capacitive or relatively low-impedance loads. The high-impedance state and increased high-logic-level drive provide these registers with the capability of being connected directly to and driving the bus lines in a bus-organized system without need for interface or pull-up components. They are particularly attractive for implementing buffer registers, I/O ports, bidirectional bus drivers, and working registers.

The eight flip-flops of the AS874 are edge-triggered D-type flip-flops. On the positive transition of the clock, the Q outputs will be set to the logic states that were set up at the D inputs.

A buffered output control input can be used to place the eight outputs in either a normal logic state (high or low logic levels) or a high-impedance state. In the high-impedance state the outputs neither load nor drive the bus lines significantly.

The output control does not affect the internal operation of the flip-flops. That is, the old data can be retained or new data can be entered even while the outputs are off.

The pinout is arranged to ease printed circuit board layout. All data inputs are on one side of the package, while all outputs are on the other side.

### Features

- Switching specifications at 50 pF
- Switching specifications guaranteed over full temperature and V<sub>CC</sub> range
- Advanced oxide-isolated, ion-implanted Schottky TTL process
- TRI-STATE buffer-type outputs drive bus lines directly
- Space saving 300 mil wide package
- Bus structured pinout

### Connection Diagram

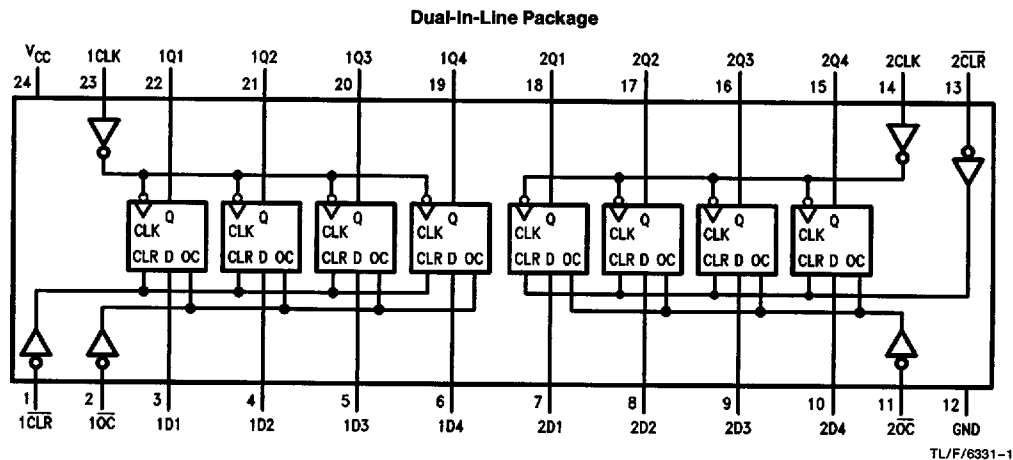

TRI-STATE® is a registered trademark of National Semiconductor Corporation.

## Absolute Maximum Ratings

Supply Voltage	7V
Input Voltage	7V
Voltage Applied to Disabled Output	5.5V
Operating Free Air Temperature Range	0°C to +70°C
Storage Temperature Range	-65°C to +150°C
Typical $\theta_{JA}$ N Package	47.0°C/W

Note: This product meets application requirements of 500 temperature cycles from -65°C to +150°C.

Note: The "Absolute Maximum Ratings" are those values beyond which the safety of the device cannot be guaranteed. The device should not be operated at these limits. The parametric values defined in the "Electrical Characteristics" table are not guaranteed at the absolute maximum ratings. The "Recommended Operating Conditions" table will define the conditions for actual device operation.

## Recommended Operating Conditions

Symbol	Parameter		Min	Nom	Max	Units
V <sub>CC</sub>	Supply Voltage		4.5	5	5.5	V
V <sub>IH</sub>	High Level Input Voltage		2			V
V <sub>IL</sub>	Low Level Input Voltage				0.8	V
I <sub>OH</sub>	High Level Output Current				-15	mA
I <sub>OL</sub>	Low Level Output Current				48	mA
f <sub>CLK</sub>	Clock Frequency		0		80	MHz
t <sub>WCLK</sub>	Width of Clock Pulse	High	3			ns
		Low	6			
t <sub>WCLR</sub>	Width of Clear Pulse	Low	2			ns
t <sub>SU</sub>	Setup Time	Data	4 ↑			ns
		Clear Inactive	5 ↑			
t <sub>H</sub>	Data Hold Time		1 ↑			ns
T <sub>A</sub>	Free Air Operating Temperature		0		70	°C

The (↑) arrow indicates the positive edge of the Clock is used for reference.

## Electrical Characteristics

over recommended operating free air temperature range. All typical values are measured at V<sub>CC</sub> = 5V, T<sub>A</sub> = 25°C.

Symbol	Parameter	Conditions	Min	Typ	Max	Units	
V <sub>IK</sub>	Input Clamp Voltage	V <sub>CC</sub> = 4.5V, I <sub>I</sub> = -18 mA			-1.2	V	
V <sub>OH</sub>	High Level Output Voltage	V <sub>CC</sub> = 4.5V, V <sub>IL</sub> = V <sub>IL</sub> Max, I <sub>OH</sub> = Max	2.4	3.3		V	
		I <sub>OH</sub> = -2 mA, V <sub>CC</sub> = 4.5V to 5.5V	V <sub>CC</sub> - 2				
V <sub>OL</sub>	Low Level Output Voltage	V <sub>CC</sub> = 4.5V, V <sub>IH</sub> = 2V, I <sub>OL</sub> = Max		0.35	0.5	V	
I <sub>I</sub>	Input Current at Max Input Voltage	V <sub>CC</sub> = 5.5V, V <sub>IH</sub> = 7V			0.1	mA	
I <sub>IH</sub>	High Level Input Current	V <sub>CC</sub> = 5.5V, V <sub>IH</sub> = 2.7V			20	μA	
I <sub>IL</sub>	Low Level Input Current	V <sub>CC</sub> = 5.5V, V <sub>IL</sub> = 0.4V			-0.5	mA	
I <sub>O</sub> (Note 1)	Output Drive Current	V <sub>CC</sub> = 5.5V, V <sub>O</sub> = 2.25V	-30		-112	mA	
I <sub>OZH</sub>	Off-State Output Current, High Level Voltage Applied	V <sub>CC</sub> = 5.5V, V <sub>IH</sub> = 2V, V <sub>O</sub> = 2.7V,			50	μA	
I <sub>OZL</sub>	Off-State Output Current, Low Level Voltage Applied	V <sub>CC</sub> = 5.5V, V <sub>IH</sub> = 2V, V <sub>O</sub> = 0.4V			-50	μA	
I <sub>CC</sub>	Supply Current	V <sub>CC</sub> = 5.5V Outputs Open	Outputs High		82	133	mA
			Outputs Low		92	149	
			Outputs Disabled		100	160	

Note 1: The output conditions have been chosen to produce a current that closely approximates one-half of the true short-circuit current, I<sub>CS</sub>.

## Switching Characteristics over recommended operating free air temperature range (Note 1)

Symbol	Parameter	Conditions	From	To	Min	Max	Units
$f_{MAX}$	Maximum Clock Frequency	$V_{CC} = 4.5V$ to $5.5V$ $R_L = 500\Omega$ $C_L = 50$ pF			80		MHz
$t_{PLH}$	Propagation Delay Time Low to High Level Output		Clock	Any Q	3	8.5	ns
$t_{PHL}$	Propagation Delay Time High to Low Level Output		Clock	Any Q	4	10.5	ns
$t_{PZH}$	Output Enable Time to High Level Output		$\overline{\text{Output Control}}$	Any Q	2	7	ns
$t_{PZL}$	Output Enable Time to Low Level Output		$\overline{\text{Output Control}}$	Any Q	3	10.5	ns
$t_{PHZ}$	Output Disable Time from High Level Output		$\overline{\text{Output Control}}$	Any Q	2	6	ns
$t_{PLZ}$	Output Disable Time from Low Level Output		$\overline{\text{Output Control}}$	Any Q	2	7.5	ns
$t_{PHL}$	Propagation Delay Time High to Low Level Output		$\overline{\text{Clear}}$	Any Q	4	11.5	ns

Note 1: See Section 5 for test waveforms and output load.

## Function Table

Inputs				Output
$\overline{\text{CLR}}$	D	CLK	$\overline{\text{OC}}$	Q
X	X	X	H	Z
L	X	X	L	L
H	H	$\uparrow$	L	H
H	L	$\uparrow$	L	L
H	X	L	L	$Q_0$

L = Low State, H = High State, X = Don't Care

$\uparrow$  = Positive Edge Transition

Z = High Impedance State

$Q_0$  = Previous Condition of Q

# Logic Diagram

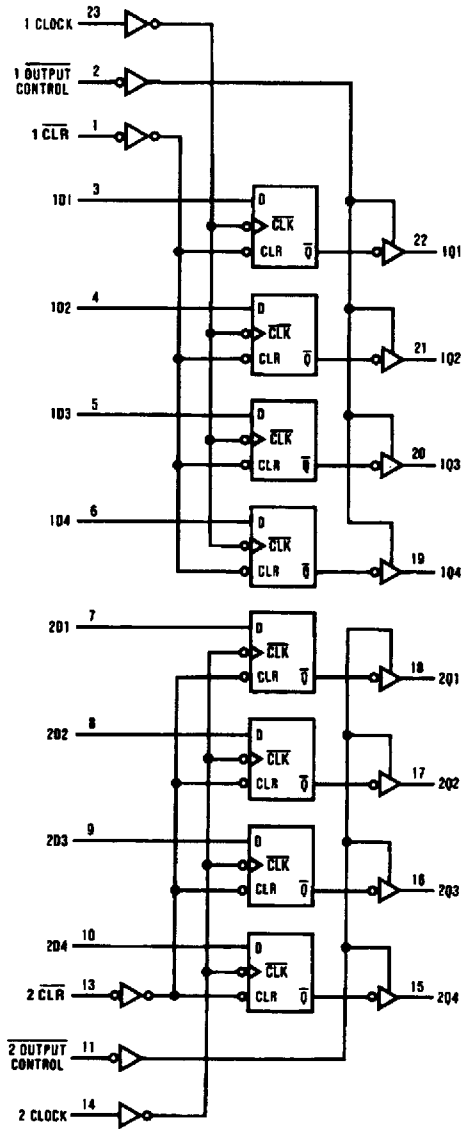

TL/F/6331-2

**Physical Dimensions** inches (millimeters)

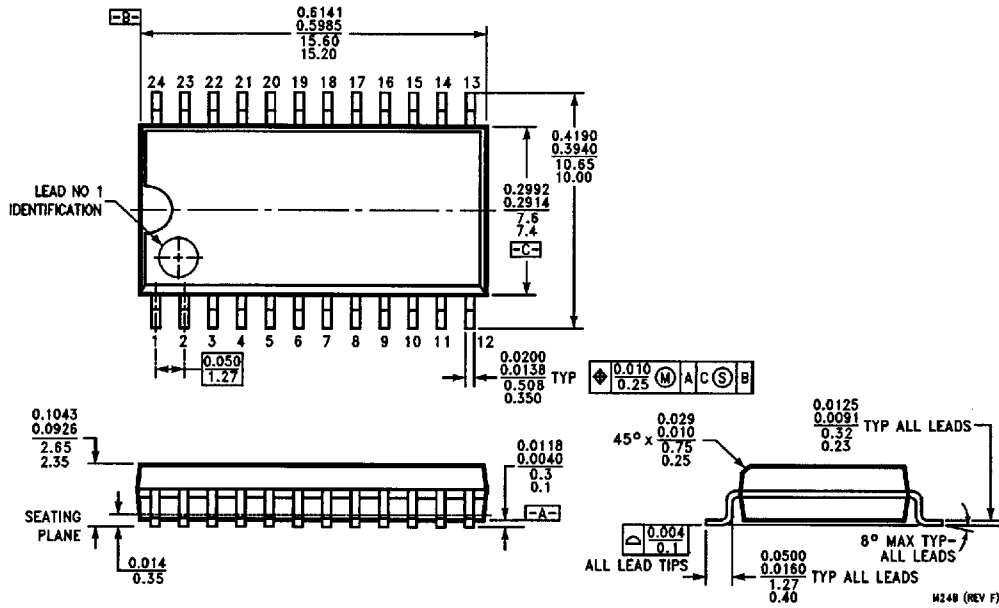

**24-Lead (0.300" Wide) Molded Small Outline Package, JEDEC (M)**  
**Order Number DM74AS874WM**  
**NS Package Number M24B**

