

Product Features

- Near-zero propagation delay
- 5-ohm switches connect inputs to outputs
- Fast Switching speed - 5ns (max.)
- Operating Range: 3.0V to 3.6V
- Industrial operating temperature: -40°C to +85°C
- Packages available:
 - 48-pin, 240-mil wide thin plastic TSSOP (A)
 - 48-pin, 300-mil wide plastic SSOP (V)

Product Description

Pericom Semiconductor's PI3B series of logic circuits are produced using the Company's advanced submicron CMOS technology.

The PI3B16209 is a 3.3 volt, 18-bit bus exchange switches designed with a low On-resistance (5 ohms) allowing inputs to be connected directly to outputs. The devices operate as either a 18-bit bus switch or as a 9-bit exchanger, providing data exchange between four signal ports via the data select pins (S0-S2).

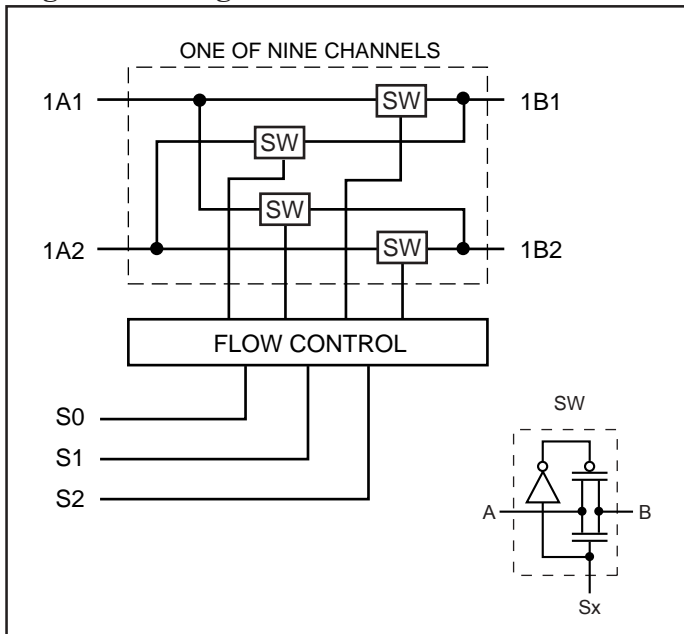
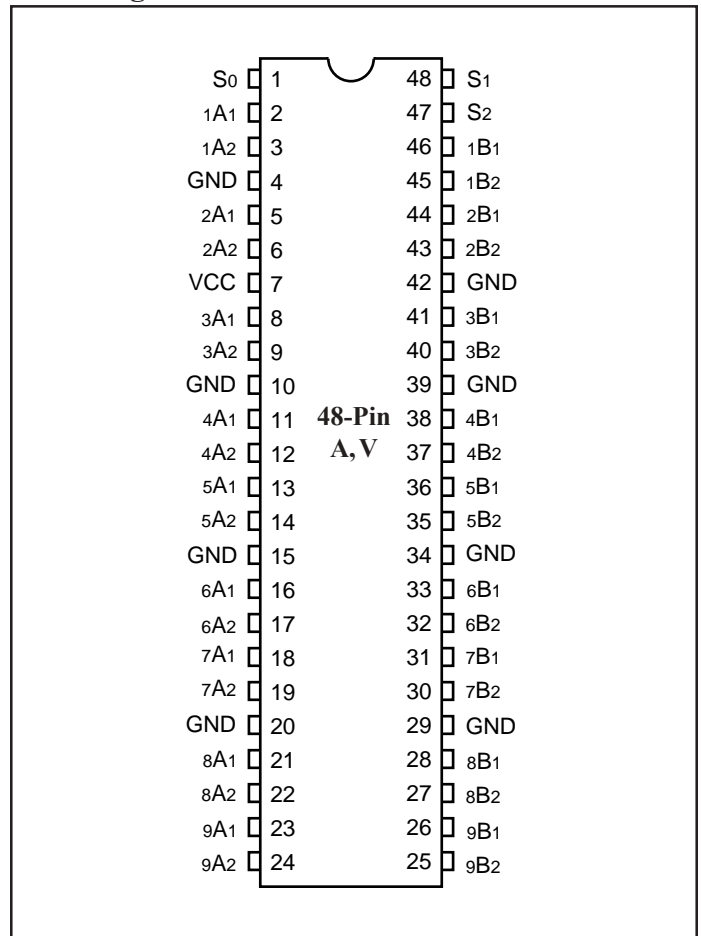
Logic Block Diagram

Pin Configuration

Truth Table

Function	S2	S1	S0	A1	A2
Disconnect	L	L	L	Z	Z
A1 to B1	L	L	H	B1	Z
A1 to B2	L	H	L	B2	Z
A2 to B1	L	H	H	Z	B1
A2 to B2	H	L	L	Z	B2
Disconnect	H	L	H	Z	Z
A1 to B1, A2 to B2	H	H	L	B1	B2
A1 to B2, A2 to B1	H	H	H	B2	B1

Note:

1. H = High Voltage Level
L = Low Voltage Level
Z = High Impedance

Pin Description

Pin Name	I/O	Description
S0-S2	I	Select Inputs
xAx	I/O	Bus A
xBx	I/O	Bus B

Maximum Ratings

(Above which the useful life may be impaired. For user guidelines, not tested.)

Storage Temperature	-65°C to +150°C
Ambient Temperature with Power Applied	-0°C to +85°C
Supply Voltage Range	-0.5V to +4.6V
DC Input Voltage	-0.5V to +4.6V
DC Output Current	120mA
Power Dissipation	0.5W

Note:

Stresses greater than those listed under MAXIMUM RATINGS may cause permanent damage to the device. This is a stress rating only and functional operation of the device at these or any other conditions above those indicated in the operational sections of this specification is not implied. Exposure to absolute maximum rating conditions for extended periods may affect reliability.

DC Electrical Characteristics (Over the Operating Range, $T_A = -40^\circ\text{C}$ to $+85^\circ\text{C}$, $V_{CC} = 3.0\text{V}$ to 3.6V)

Parameters	Description	Test Conditions ⁽¹⁾	Min.	Typ ⁽²⁾	Max.	Units
V_{IH}	Input HIGH Voltage	Guaranteed Logic HIGH Level	2.0	–	–	V
V_{IL}	Input LOW Voltage	Guaranteed Logic LOW Level	-0.5	–	0.8	
I_{IH}	Input High Current	$V_{CC} = \text{Max.}, V_{IN} = V_{CC}$	–	–	± 1	μA
I_{IL}	Input Low Current	$V_{CC} = \text{Max.}, V_{IN} = \text{GND}$	–	–	± 1	
I_{OZH}	High Impedance Output Current	$0 \leq A, B, \leq V_{CC}$	–	–	± 1	
V_{IK}	Clamp Diode Voltage	$V_{CC} = \text{Min.}, I_{IN} = -18\text{mA}$	–	-0.7	-1.2	V
R_{ON}	Switch ON Resistance ⁽³⁾	$V_{CC} = \text{Min.}, V_{IN} = 0.0\text{V}, I_{ON} = 48\text{mA}$	–	5	8	Ω
		$V_{CC} = \text{Min.}, V_{IN} = 2.4\text{V}, I_{ON} = 15\text{mA}$	–	10	15	

Capacitance ($T_A = 25^\circ\text{C}$, $f = 1\text{MHz}$)

Parameters ⁽⁴⁾	Description	Test Conditions	Typ	Units
C_{IN}	Input Capacitance	$V_{IN} = 0\text{V}$	3	pF
C_{OFF}	A/B Capacitance, Switch Off		14	
C_{ON}	A/B Capacitance, Switch On		30	

Notes:

- For Max. or Min. conditions, use appropriate value specified under Electrical Characteristics for the applicable device type.
- Typical values are at $V_{CC} = 3.3\text{V}$, $T_A = 25^\circ\text{C}$ ambient and maximum loading.
- Measured by the voltage drop between A and B pin at indicated current through the switch. ON resistance is determined by the lower of the voltages on the two (A,B) pins.
- This parameter is determined by device characterization but is not production tested.

Power Supply Characteristics

Parameters	Description	Test Conditions ⁽¹⁾		Min.	Typ ⁽²⁾	Max.	Units
I _{CC}	Quiescent Power Supply Current	V _{CC} = Max.	V _{IN} = GND or V _{CC}			10	μA
ΔI _{CC}	Supply Current per Input @ TTL HIGH	V _{CC} = Max.	V _{IN} = 3.0V ⁽³⁾			750	
I _{CCD}	Supply Current per Input per MHz ⁽⁴⁾	V _{CC} = Max. A & B Pins Open BE = GND Control Input Toggling 50% Duty Cycle				0.25	mA/ MHz

Notes:

1. For Max. or Min. conditions, use appropriate value specified under Electrical Characteristics for the applicable device.
2. Typical values are at V_{CC} = 3.3V, +25°C ambient.
3. Per TTL driven input (control input only); A and B pins do not contribute to I_{CC}.
4. This current applies to the control inputs only and represent the current required to switch internal capacitance at the specified frequency. The A and B inputs generate no significant AC or DC currents as they transition. This parameter is not tested, but is guaranteed by design.

Switching Characteristics over Operating Range

Parameters	Description	Conditions ⁽¹⁾	Com.		Units
			Min.	Max.	
t _{PLH} t _{PHL}	Bus Enable Time BE to Ax or Bx	C _L = 50pF R _L = 500 ohms		0.25	ns
t _{PZH} t _{PZL}	Bus Enable Time BE to Ax or Bx	C _L = 50pF R _L = 500 ohms	1	4.5	
t _{PHZ} t _{PLZ}	Bus Disable Time BE to Ax or Bx	R = 500 ohms	1	5	

Notes:

1. See test circuit and waveforms.
2. This parameter is guaranteed but not tested on Propagation Delays.
3. The bus switch contributes no propagational delay other than the RC delay of the ON resistance of the switch and the load capacitance. The time constant for the switch alone is of the order of 0.25ns for 50pF load. Since this time constant is much smaller than the rise/fall times of typical driving signals, it adds very little propagational delay to the system. Propagational delay of the bus switch when used in a system is determined by the driving circuit on the driving side of the switch and its interaction with the load on the driven side.

48-Pin TSSOP (A) Package

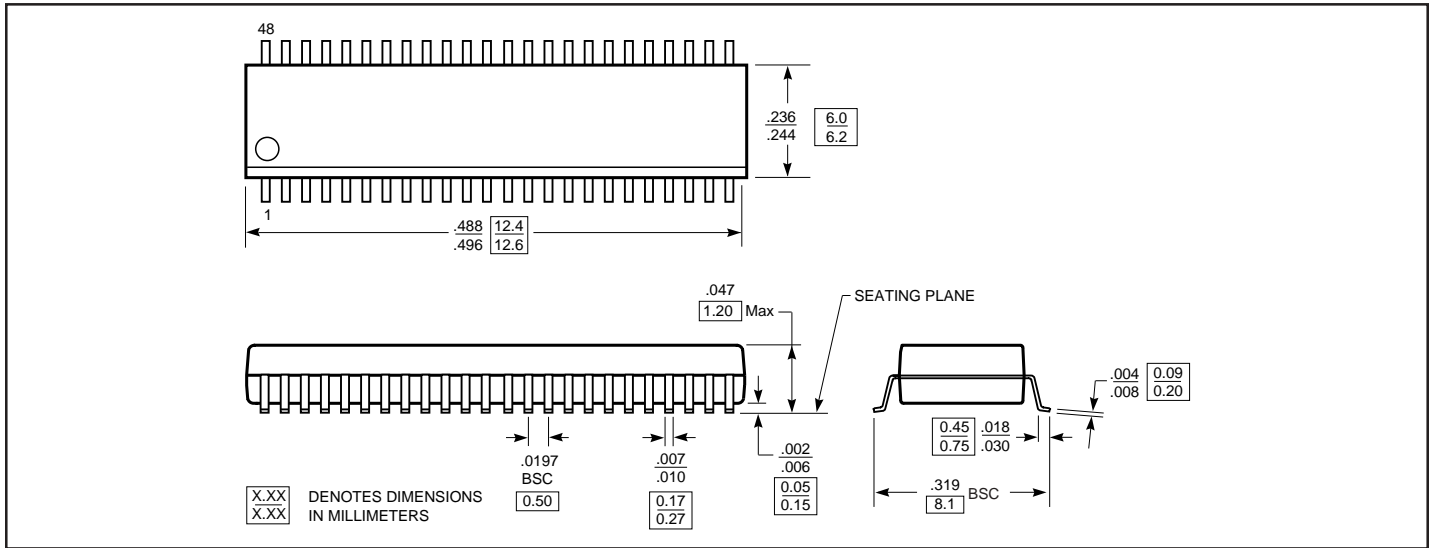

48-Pin SSOP (V) Package

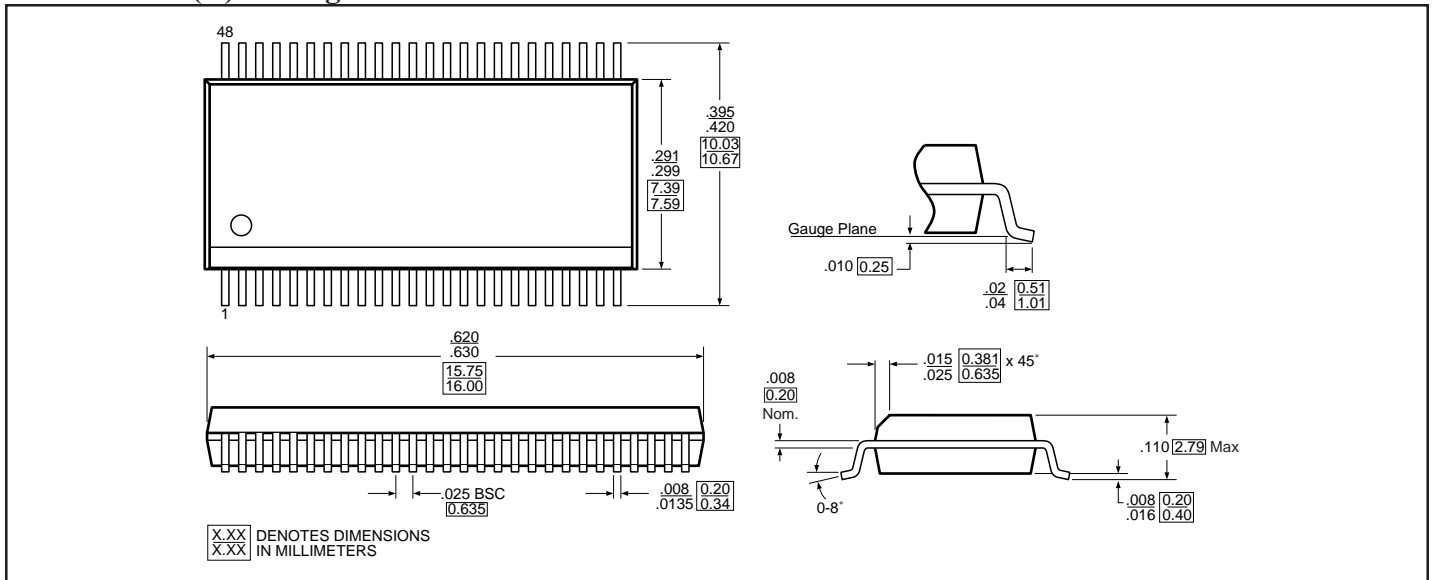

Ordering Information

Part	Pin - Package	Temperature
PI3B16209V	48 - SSOP (V)	-40°C to +85°C
PI3B16209A	48 - TSSOP (A)	

Applications Information

Logic Inputs

The logic control inputs can be driven up to +3.6V regardless of the supply voltage. For example, given a +3.3V supply, IN may be driven low to 0V and high to 3.6V. Driving IN Rail-to-Rail® minimizes power consumption.

Power-Supply Sequencing and Hot-Plug Information

Proper power-supply sequencing is recommended for all CMOS devices. Always apply V_{CC} and GND before applying signals to input/output or control pins.

Rail-to-Rail is a registered trademark of Nippon Motorola, Ltd.