

SN74ALS156
DECODER/DEMULTIPLEXER
WITH OPEN-COLLECTOR OUTPUTS
 SDAS099C – JUNE 1986 – REVISED MAY 1996

- **Applications:**
 - Dual 2-Line to 4-Line Decoder
 - Dual 1-Line to 4-Line Demultiplexer
 - 3-Line to 8-Line Decoder
 - 1-Line to 8-Line Demultiplexer
- **Individual Strobes Simplify Cascading for Decoding or Demultiplexing Larger Words**
- **Package Options Include Plastic Small-Outline (D) Packages and Standard Plastic (N) 300-mil DIPs**

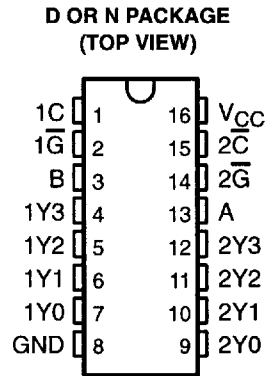

description

One of the main applications of the SN74ALS156 is as a dual 1-line to 4-line decoder/demultiplexer with individual strobes (\bar{G}) and common binary-address inputs in a single 16-pin package. When both sections are enabled, the common binary-address inputs sequentially select and route associated input data to the appropriate output of each section. The individual strobes permit enabling or disabling each of the 4-bit sections, as desired.

Data applied to input 1C is inverted at its outputs and data applied at input 2 \bar{C} is not inverted through its outputs. The inverter following the 1C data input permits use of the SN74ALS156 as a 3-line to 8-line demultiplexer without external gating. All inputs are clamped with high-performance Schottky diodes to suppress line ringing and simplify system design.

The SN74ALS156 is characterized for operation from 0°C to 70°C.



Please be aware that an important notice concerning availability, standard warranty, and use in critical applications of Texas Instruments semiconductor products and disclaimers thereto appears at the end of this data sheet.

PRODUCTION DATA information is current as of publication date. Products conform to specifications per the terms of Texas Instruments standard warranty. Production processing does not necessarily include testing of all parameters.



POST OFFICE BOX 655303 • DALLAS, TEXAS 75265

Copyright © 1996, Texas Instruments Incorporated

SN74ALS156
DECODER/DEMULTIPLEXER
WITH OPEN-COLLECTOR OUTPUTS

SDAS099C – JUNE 1986 – REVISED MAY 1996

Function Tables

**2-LINE TO 4-LINE DECODER OR
 1-LINE TO 4-LINE DEMULTIPLEXER**

INPUTS				OUTPUTS			
SELECT		STROBE	DATA				
B	A	1 \bar{G}	1C	1Y0	1Y1	1Y2	1Y3
X	X	H	X	H	H	H	H
L	L	L	H	L	H	H	H
L	H	L	H	H	L	H	H
H	L	L	H	H	H	L	H
H	H	L	H	H	H	H	L
X	X	X	L	H	H	H	H

**2-LINE TO 4-LINE DECODER OR
 1-LINE TO 4-LINE DEMULTIPLEXER**

INPUTS				OUTPUTS			
SELECT		STROBE	DATA				
B	A	2 \bar{G}	2C	2Y0	2Y1	2Y2	2Y3
X	X	H	X	H	H	H	H
L	L	L	L	L	H	H	H
L	H	L	L	H	L	H	H
H	L	L	L	H	H	L	H
H	H	L	L	H	H	H	L
X	X	X	H	H	H	H	H

**3-LINE TO 8-LINE DECODER OR
 1-LINE TO 8-LINE DEMULTIPLEXER**

INPUTS				OUTPUTS							
SELECT			STROBE OR DATA \bar{G}^\ddagger	0	1	2	3	4	5	6	7
C †	B	A		2Y0	2Y1	2Y2	2Y3	1Y0	1Y1	1Y2	1Y3
X	X	X	H	H	H	H	H	H	H	H	H
L	L	L	L	L	H	H	H	L	H	H	H
L	L	H	L	H	L	H	H	H	L	H	H
L	H	L	L	H	H	L	H	H	H	H	H
L	H	H	L	H	H	H	L	H	H	H	H
H	L	L	L	H	H	H	H	L	H	H	H
H	L	H	L	H	H	H	H	H	L	H	H
H	H	L	L	H	H	L	H	H	H	L	H
H	H	H	L	H	H	H	L	H	H	H	L

† C = inputs 1C and 2 \bar{C} connected together

‡ \bar{G} = inputs 1 \bar{G} and 2 \bar{G} connected together



POST OFFICE BOX 655303 • DALLAS, TEXAS 75265

logic symbols† (alternatives)

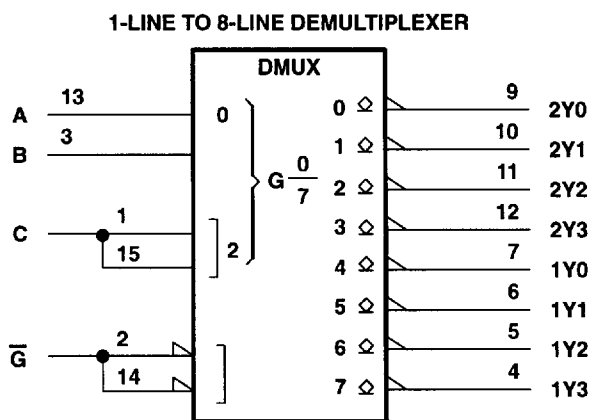
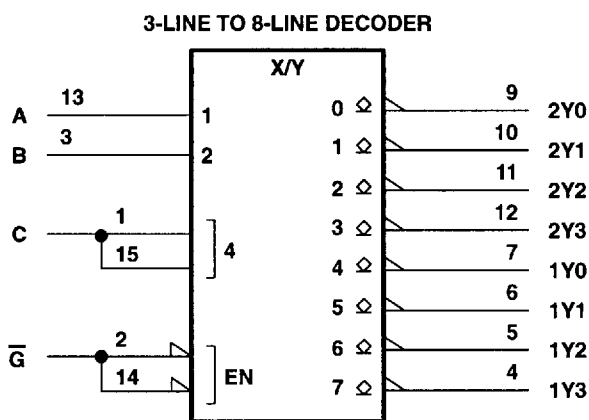
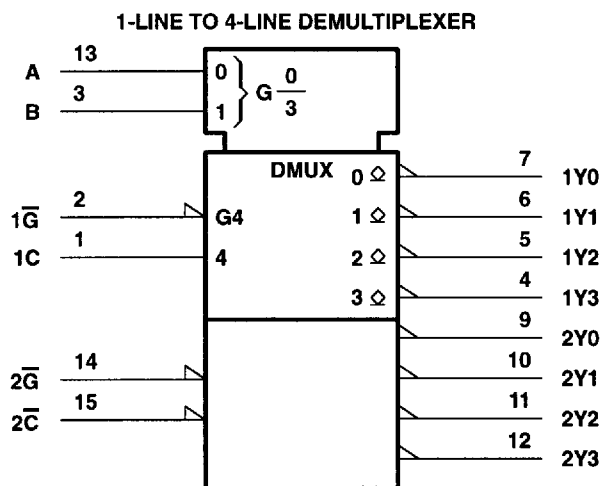
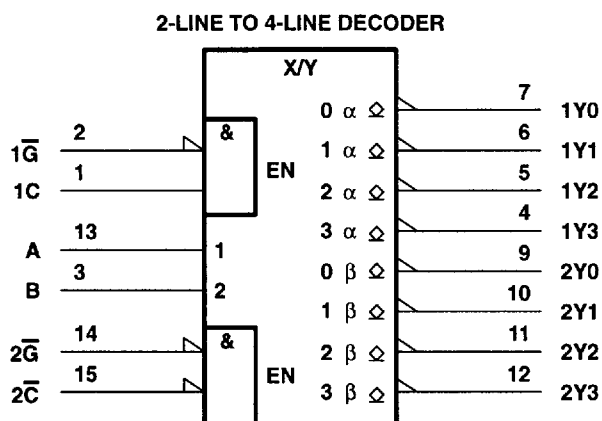

† These symbols are in accordance with ANSI/IEEE Std 91-1984 and IEC Publication 617-12.

SN74ALS156 DECODER/DEMULTIPLEXER WITH OPEN-COLLECTOR OUTPUTS

SDAS099C – JUNE 1986 – REVISED MAY 1996

logic diagram (positive logic)

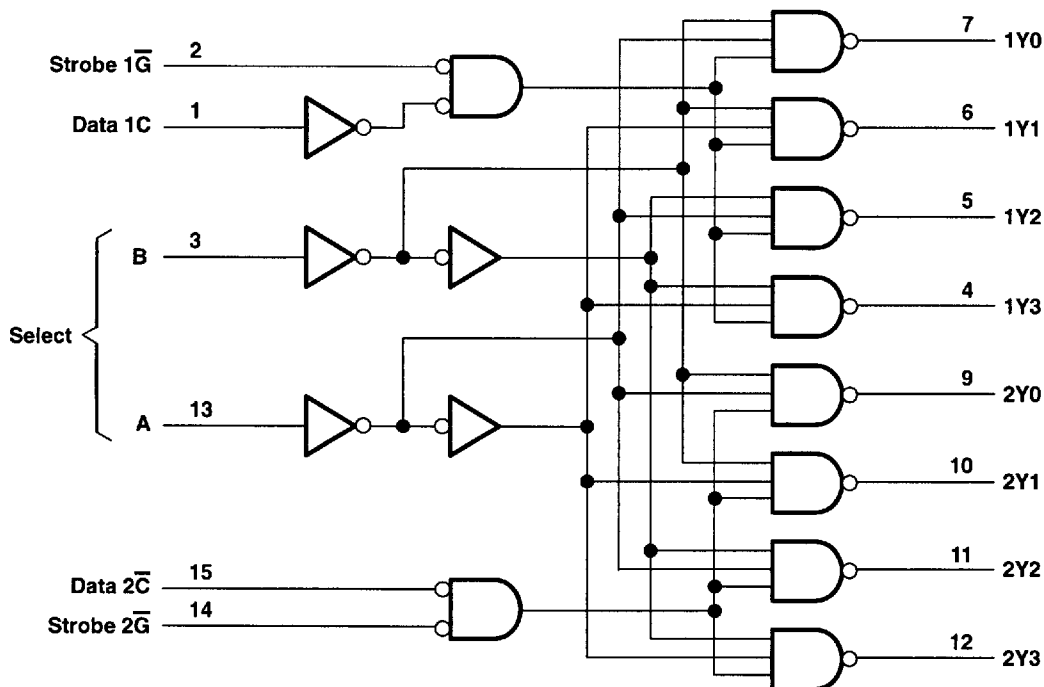

absolute maximum ratings over operating free-air temperature range (unless otherwise noted)†

Supply voltage, V_{CC}	7 V
Input voltage, V_I	7 V
Operating free-air temperature range, T_A	0°C to 70°C
Storage temperature range, T_{stg}	-65°C to 150°C

† Stresses beyond those listed under "absolute maximum ratings" may cause permanent damage to the device. These are stress ratings only, and functional operation of the device at these or any other conditions beyond those indicated under "recommended operating conditions" is not implied. Exposure to absolute-maximum-rated conditions for extended periods may affect device reliability.

recommended operating conditions

	MIN	NOM	MAX	UNIT
V_{CC} Supply voltage	4.5	5	5.5	V
V_{IH} High-level input voltage	2			V
V_{IL} Low-level input voltage			0.8	V
V_{OH} High-level output voltage			5.5	V
I_{OL} Low-level output current			8	mA
T_A Operating free-air temperature	0		70	°C



POST OFFICE BOX 655303 • DALLAS, TEXAS 75265

electrical characteristics over recommended operating free-air temperature range (unless otherwise noted)

PARAMETER	TEST CONDITIONS		MIN	TYP†	MAX	UNIT
V_{IK}	$V_{CC} = 4.5 \text{ V}$,	$I_I = -18 \text{ mA}$			-1.5	V
V_{OL}	$V_{CC} = 4.5 \text{ V}$	$I_{OL} = 4 \text{ mA}$		0.25	0.4	V
		$I_{OL} = 8 \text{ mA}$		0.35	0.5	
I_{OH}	$V_{CC} = 4.5 \text{ V}$,	$V_{OH} = 5.5 \text{ V}$			0.1	mA
I_I	$V_{CC} = 5.5 \text{ V}$,	$V_I = 7 \text{ V}$			0.1	mA
I_{IH}	$V_{CC} = 5.5 \text{ V}$,	$V_I = 2.7 \text{ V}$			20	μA
I_{IL}	$V_{CC} = 5.5 \text{ V}$,	$V_I = 0.4 \text{ V}$			-0.1	μA
I_{CCL}	$V_{CC} = 5.5 \text{ V}$			5	9	mA

† All typical values are at $V_{CC} = 5 \text{ V}$, $T_A = 25^\circ\text{C}$.

switching characteristics (see Figure 1)

PARAMETER	FROM (INPUT)	TO (OUTPUT)	$V_{CC} = 4.5 \text{ V to } 5.5 \text{ V}$, $C_L = 50 \text{ pF}$, $R_L = 500 \Omega$, $T_A = \text{MIN to MAX}^\ddagger$		UNIT
			MIN	MAX	
t_{PLH}	A, B	1Y, 2Y	7	55	ns
t_{PHL}			6	25	
t_{PLH}	1C	1Y	7	50	ns
t_{PHL}			6	23	
t_{PLH}	$1\bar{G}$	1Y	7	38	ns
t_{PHL}			6	22	
t_{PLH}	$2\bar{C}, 2\bar{G}$	2Y	7	38	ns
t_{PHL}			6	22	

‡ For conditions shown as MIN or MAX, use the appropriate value specified under recommended operating conditions.



SN74ALS156
DECODER/DEMULTIPLEXER
WITH OPEN-COLLECTOR OUTPUTS

SDAS099C - JUNE 1986 - REVISED MAY 1996

PARAMETER MEASUREMENT INFORMATION
SERIES 54ALS/74ALS AND 54AS/74AS DEVICES

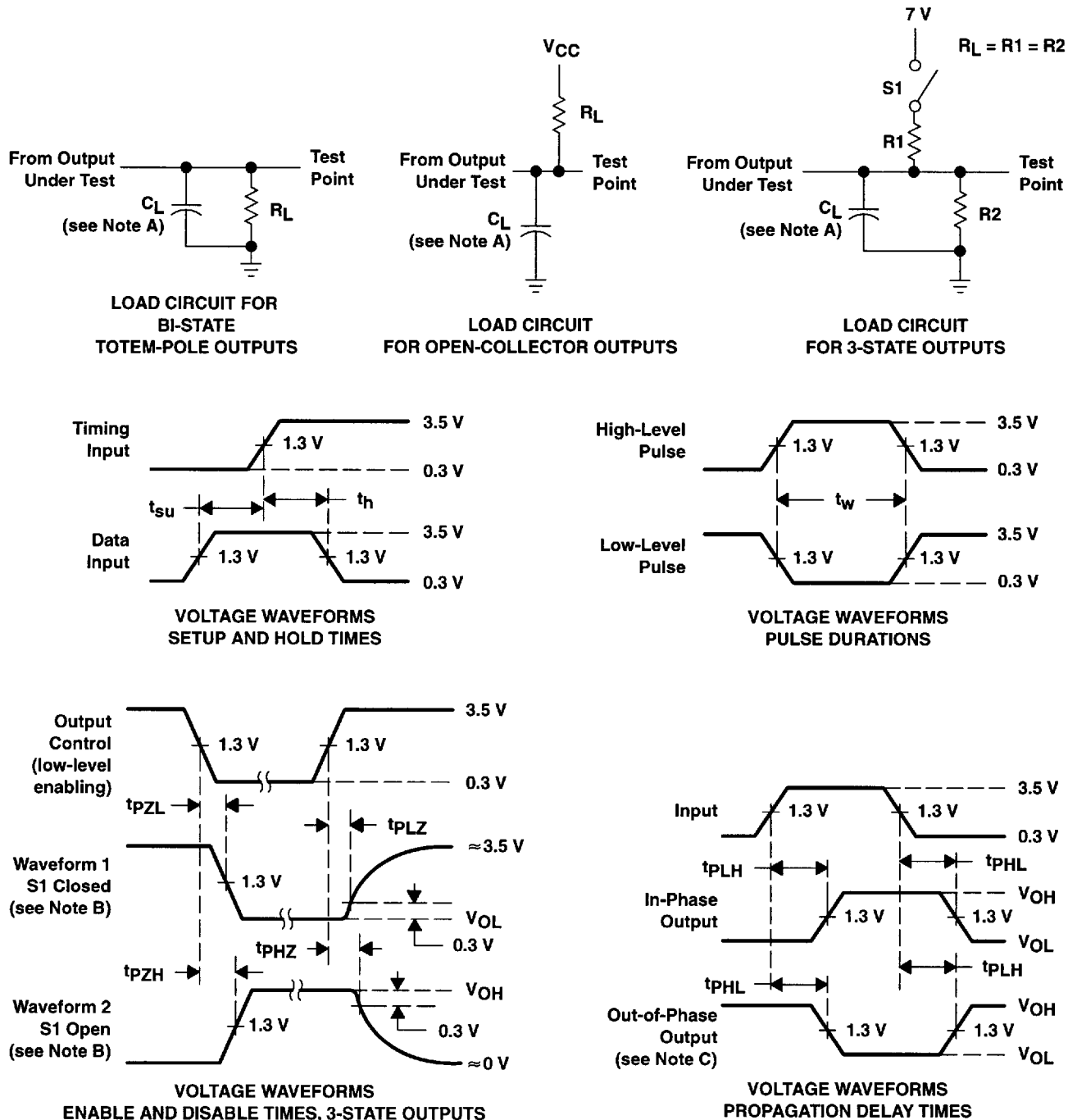

- NOTES: A. C_L includes probe and jig capacitance.
 B. Waveform 1 is for an output with internal conditions such that the output is low except when disabled by the output control. Waveform 2 is for an output with internal conditions such that the output is high except when disabled by the output control.
 C. When measuring propagation delay items of 3-state outputs, switch S1 is open.
 D. All input pulses have the following characteristics: $PRR \leq 1$ MHz, $t_r = t_f = 2$ ns, duty cycle = 50%.
 E. The outputs are measured one at a time with one transition per measurement.

Figure 1. Load Circuits and Voltage Waveforms



POST OFFICE BOX 655303 • DALLAS, TEXAS 75265