



# BZD27C3V6P~BZD27C75P

## VOLTAGE REGULATOR DIODES

**VOLTAGE** 3.6 to 75 Volt **POWER** 1 W

**SOD-123FL** Unit : inch(mm)

### FEATURES

- Silicon Planar Zener Diode
- Low profile surface-mount package
- Zener and surge current specification
- Low leakage current
- Excellent stability
- High temperature soldering : 260°C/10 sec. at terminals
- Lead free in compliance with EU RoHS2.0
- Green molding compound as per IEC 61249 standard

### MECHANICAL DATA

- Case: SOD-123FL
- Terminals : Solderable per MIL-STD-750, Method 2026
- Approx Weight: 0.0006 ounces, 0.0173 grams

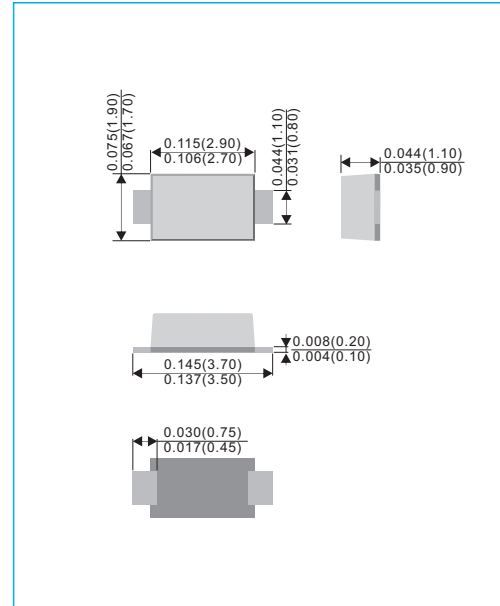
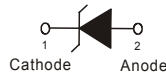

### ABSOLUTE MAXIMUM RATINGS (T<sub>A</sub>=25°C, unless otherwise specified)

Parameter	Test condition	Symbol	Value	Units
Power dissipation	T <sub>L</sub> = 80°C T <sub>A</sub> = 25°C	P <sub>TOT</sub>	2.3	W
		P <sub>TOT</sub>	1 (note 1)	
Non-repetitive peak pulse power dissipation	100 μs square pulse (note 2) 10/1000 μs waveform (BZD27-C7V5P to BZD27-75P)	P <sub>ZSM</sub>	300	W
		P <sub>RSM</sub>	150	

### THERMAL CHARACTERISTICS (T<sub>A</sub>=25°C, unless otherwise noted)

Parameter	Symbol	Value	Unit
Typical thermal resistance junction to ambient	R <sub>θJA</sub>	180	°C/W
Typical thermal resistance junction to lead	R <sub>θJL</sub>	30	°C/W
Operating junction temperature range	T <sub>J</sub>	-55 to + 150	°C
Storage temperature range	T <sub>STG</sub>	-55 to + 150	°C

### ELECTRICAL CHARACTERISTICS

Parameter	Test condition	Symbol	Min	Typ	Max	Units
Forward voltage	I <sub>F</sub> =0.2A	V <sub>F</sub>	-	-	1.2	V

#### NOTES :

1. Mounted on a FR4 PCB, single-sided copper, with 100cm<sup>2</sup> copper pad area.
2. T<sub>J</sub>=25°C prior to surge.



# BZD27C3V6P~BZD27C75P

Part Number	Nominal Zener Voltage			Max. Zener Impedance				Max Reverse Leakage Current		Marking Code
	V <sub>Z</sub> @I <sub>ZT</sub>			Z <sub>ZT</sub> @I <sub>ZT</sub>		Z <sub>ZK</sub> @I <sub>ZK</sub>		I <sub>R</sub> @V <sub>R</sub>		
	Nom. V	Min. V	Max. V	Ω	mA	Ω	mA	μA	V	
BZD27C3V6P	3.6	3.42	3.78	8	100	400	1	100	1	3V6
BZD27C3V9P	3.9	3.71	4.10	8	100	400	1	50	1	3V9
BZD27C4V3P	4.3	4.09	4.52	7	100	400	1	25	1	4V3
BZD27C4V7P	4.7	4.47	4.94	7	100	500	1	10	1	4V7
BZD27C5V1P	5.1	4.85	5.36	6	100	550	1	5	1	5V1
BZD27C5V6P	5.6	5.32	5.88	4	100	600	1	10	2	5V6
BZD27C6V0P	6.0	5.70	6.30	3	100	600	1	8	2	6V1
BZD27C6V2P	6.2	5.89	6.51	3	100	700	1	5	2	6V2
BZD27C6V8P	6.8	6.46	7.14	3	100	700	1	10	3	6V8
BZD27C7V5P	7.5	7.13	7.88	2	100	700	0.5	50	3	7V5
BZD27C8V2P	8.2	7.79	8.61	2	100	700	0.5	10	3	8V2
BZD27C8V7P	8.7	8.27	9.14	3	50	700	0.5	10	4	8V7
BZD27C9V1P	9.1	8.65	9.56	4	50	700	0.5	10	5	9V1
BZD27C10P	10	9.50	10.50	4	50	700	0.25	7	7.5	10P
BZD27C11P	11	10.45	11.55	7	50	700	0.25	4	8.2	11P
BZD27C12P	12	11.40	12.60	7	50	700	0.25	3	9.1	12P
BZD27C13P	13	12.35	13.65	10	50	700	0.25	2	10	13P
BZD27C14P	14	13.30	14.70	10	50	700	0.25	2	11	14P
BZD27C15P	15	14.25	15.75	10	50	700	0.25	1	11	15P
BZD27C16P	16	15.20	16.80	15	25	700	0.25	1	12	16P
BZD27C17P	17	16.15	17.85	15	25	750	0.25	1	13	17P
BZD27C18P	18	17.10	18.90	15	25	750	0.25	1	13	18P
BZD27C19P	19	18.05	19.95	15	25	750	0.25	1	14	19P
BZD27C20P	20	19.00	21.0	15	25	750	0.25	1	15	20P
BZD27C22P	22	20.90	23.10	15	25	750	0.25	1	16	22P
BZD27C24P	24	22.80	25.20	15	25	750	0.25	1	18	24P
BZD27C25P	25	23.75	26.25	15	25	750	0.25	1	19	25P
BZD27C27P	27	25.65	28.35	15	25	1000	0.25	1	20	27P
BZD27C28P	28	26.60	29.40	15	25	1000	0.25	1	21	28P
BZD27C30P	30	28.50	31.50	15	25	1000	0.25	1	22	30P
BZD27C33P	33	31.35	34.65	15	25	1000	0.25	1	24	33P
BZD27C36P	36	34.20	37.80	40	10	1000	0.25	1	27	36P
BZD27C39P	39	37.05	40.95	40	10	1000	0.25	1	30	39P
BZD27C43P	43	40.85	45.15	45	10	1500	0.25	1	33	43P
BZD27C47P	47	44.65	49.35	45	10	1500	0.25	1	36	47P
BZD27C51P	51	48.45	53.55	60	10	1500	0.25	1	39	51P
BZD27C56P	56	53.2	58.8	60	10	2000	0.25	1	43	56P
BZD27C62P	62	58.9	65.1	80	10	2000	0.25	1	47	62P
BZD27C68P	68	64.6	71.4	80	10	2000	0.25	1	51	68P
BZD27C75P	75	71.25	78.75	100	10	2000	0.25	1	56	75P



# BZD27C3V6P~BZD27C75P

Typical Characteristics ( $T_A=25^\circ\text{C}$  unless otherwise specified)

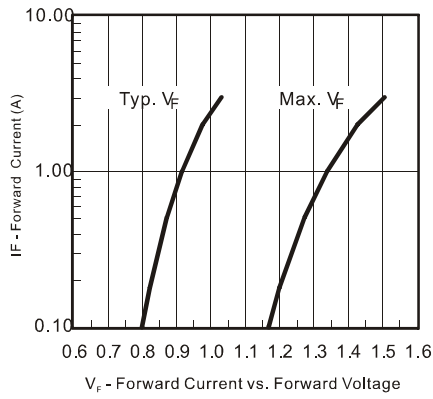

Figure1. Forward Current vs. Forward Voltage

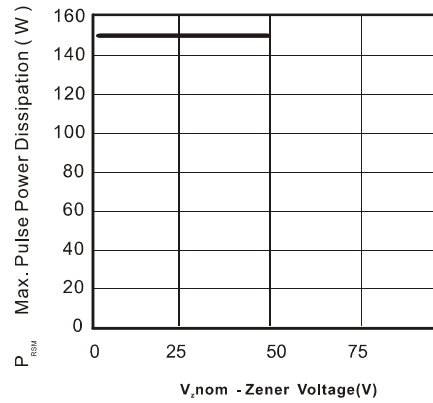

Figure4. Maximum Pulse Power Dissipation vs. Zener Voltage

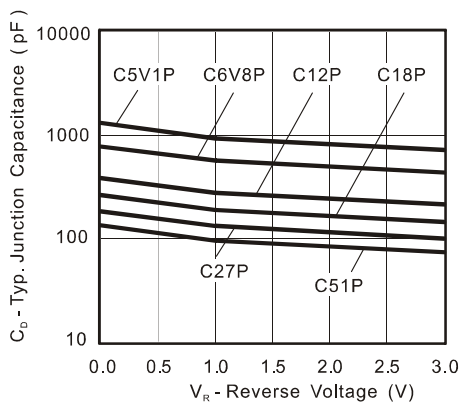

Figure2. Typ. Diode Capacitance vs. Reverse Voltage

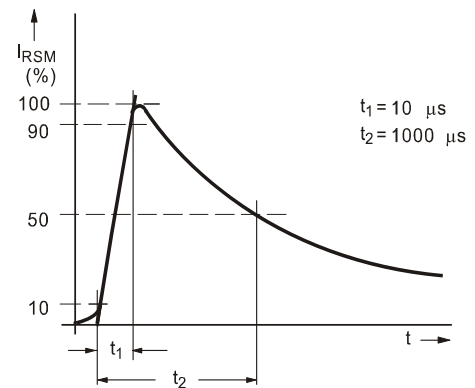

Figure5. Non-Repetitive Peak Reverse Current Pulse Definition

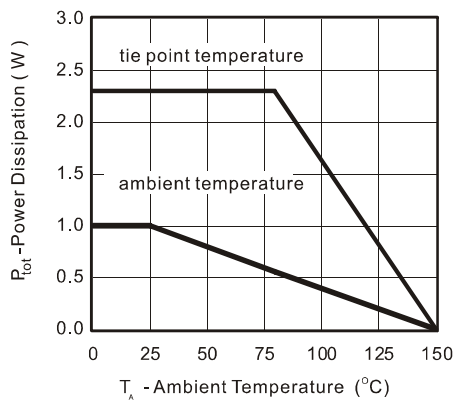

Figure3. Power Dissipation vs. Ambient Temperature



# BZD27C3V6P~BZD27C75P

## MOUNTING PAD LAYOUT

SOD-123FL

Unit : inch(mm)

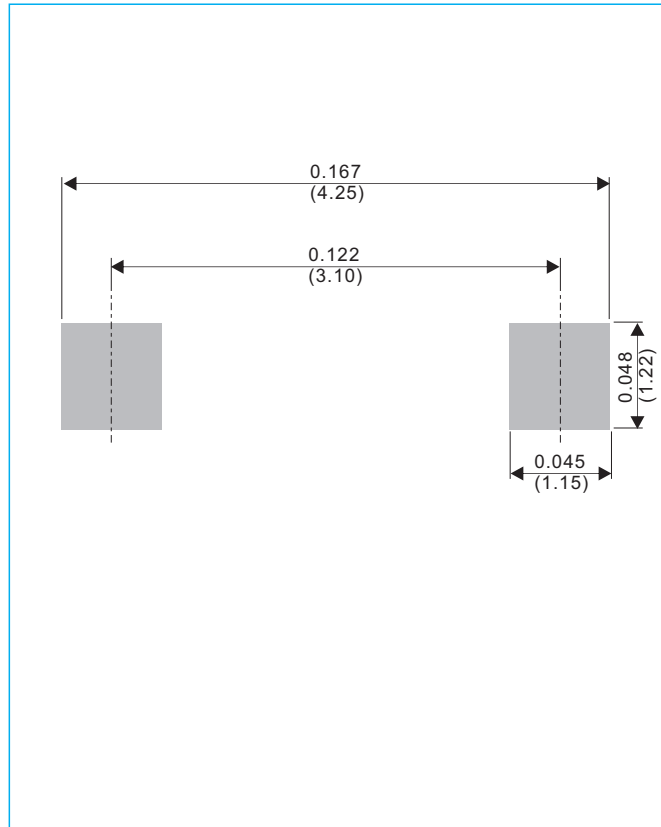

## ORDER INFORMATION

- Packing information  
T/R - 10K per 13" plastic Reel  
T/R - 3K per 7" plastic Reel



# BZD27C3V6P~BZD27C75P

## Part No\_packing code\_Version

BZD27C3V6P\_R1\_00001

BZD27C3V6P\_R2\_00001

For example :

**RB500V-40\_R2\_00001**



Packing Code <b>XX</b>				Version Code <b>XXXXX</b>		
Packing type	1 <sup>st</sup> Code	Packing size code	2 <sup>nd</sup> Code	HF or RoHS	1 <sup>st</sup> Code	2 <sup>nd</sup> ~5 <sup>th</sup> Code
Tape and Ammunition Box (T/B)	<b>A</b>	N/A	<b>0</b>	<b>HF</b>	<b>0</b>	serial number
Tape and Reel (T/R)	<b>R</b>	7"	<b>1</b>	<b>RoHS</b>	<b>1</b>	serial number
Bulk Packing (B/P)	<b>B</b>	13"	<b>2</b>			
Tube Packing (T/P)	<b>T</b>	26mm	<b>X</b>			
Tape and Reel (Right Oriented) (TRR)	<b>S</b>	52mm	<b>Y</b>			
Tape and Reel (Left Oriented) (TRL)	<b>L</b>	PANASERT T/B CATHODE UP (PBCU)	<b>U</b>			
FORMING	<b>F</b>	PANASERT T/B CATHODE DOWN (PBCD)	<b>D</b>			



## BZD27C3V6P~BZD27C75P

---

### Disclaimer

- Reproducing and modifying information of the document is prohibited without permission from Panjit International Inc..
- Panjit International Inc. reserves the rights to make changes of the content herein the document anytime without notification. Please refer to our website for the latest document.
- Panjit International Inc. disclaims any and all liability arising out of the application or use of any product including damages incidentally and consequentially occurred.
- Panjit International Inc. does not assume any and all implied warranties, including warranties of fitness for particular purpose, non-infringement and merchantability.
- Applications shown on the herein document are examples of standard use and operation. Customers are responsible in comprehending the suitable use in particular applications. Panjit International Inc. makes no representation or warranty that such applications will be suitable for the specified use without further testing or modification.
- The products shown herein are not designed and authorized for equipments requiring high level of reliability or relating to human life and for any applications concerning life-saving or life-sustaining, such as medical instruments, transportation equipment, aerospace machinery et cetera. Customers using or selling these products for use in such applications do so at their own risk and agree to fully indemnify Panjit International Inc. for any damages resulting from such improper use or sale.
- Since Panjit uses lot number as the tracking base, please provide the lot number for tracking when complaining.