

Features

- ✧ Designed for use in switching power supplies, inverters and as free wheeling diodes
- ✧ High efficiency, low VF
- ✧ High reliability
- ✧ Ultrafast recovery time for high efficiency
- ✧ 175°C operating junction temperature
- ✧ Green compound with suffix "G" on packing code & prefix "G" on datecode



Mechanical Data

- ✧ Case: Molded plastic
- ✧ Epoxy: UL 94V-0 rate flame retardant
- ✧ Lead: Pure tin plated, lead free, solderable per MIL-STD-202, Method 208 guaranteed
- ✧ Polarity: color band denotes cathode
- ✧ Solder dip 260°C max.10s per JESD 22-B106
- ✧ Weight: 0.34 grams

Ordering Information (example)

Part No.	Package	Packing	INNER TAPE	Packing code	Packing code (Green)
MUR16A	DO-41	3K / AMMO box	52mm	A0	A0G

Maximum Ratings and Electrical Characteristics

Rating at 25 °C ambient temperature unless otherwise specified.

Parameter	Symbol	MUR160A	MUR190A	Unit
Maximum Repetitive Peak Reverse Voltage	V_{RRM}	600	900	V
Maximum RMS Voltage	V_{RMS}	420	630	V
Maximum DC Blocking Voltage	V_{DC}	600	900	V
Maximum Average Forward Rectified Current	$I_{F(AV)}$	1		A
Peak Forward Surge Current, 8.3 ms Single Half Sine-wave Superimposed on Rated Load (JEDEC method)	I_{FSM}	35		A
Maximum Instantaneous Forward Voltage (Note 1) @ 1.0A $T_A=25^\circ\text{C}$ $T_A=150^\circ\text{C}$	V_F	1.25 1.05	1.70 1.50	V
Maximum Reverse Current @ Rated VR $T_A=25^\circ\text{C}$ $T_A=125^\circ\text{C}$	I_R	5 150		μA
Maximum Reverse Recovery Time (Note 2)	T_{rr}	50	75	nS
Typical Junction Capacitance (Note 3)	C_j	27	15	pF
Typical Thermal Resistance	$R_{\theta JA}$	50		$^\circ\text{C/W}$
Operating Temperature Range	T_J	- 55 to + 175		$^\circ\text{C}$
Storage Temperature Range	T_{STG}	- 55 to + 175		$^\circ\text{C}$

Note 1: Pulse Test with PW=300 usec, 1% Duty Cycle

Note 2: Reverse Recovery Test Conditions: $I_F=0.5\text{A}$, $I_R=1.0\text{A}$, $I_{RR}=0.25\text{A}$

Note 3: Measured at 1 MHz and Applied Reverse Voltage of 4.0V D.C.

RATINGS AND CHARACTERISTIC CURVES (MUR160A THRU MUR190A)

FIG.1 FORWARD CURRENT DERATING CURVE

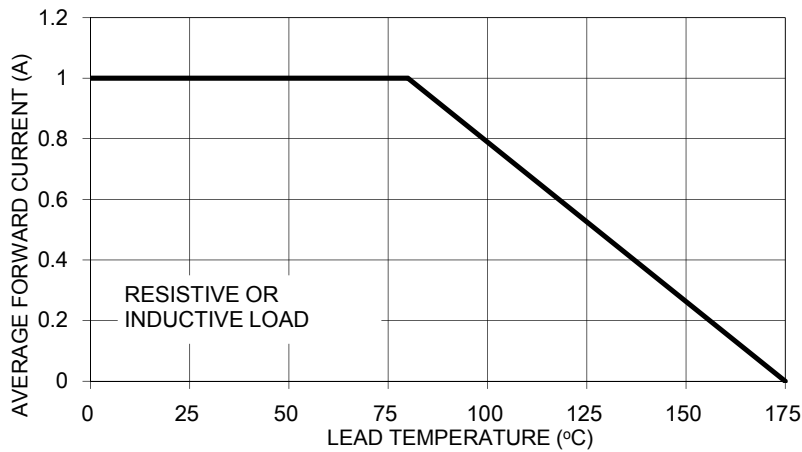

FIG. 2 TYPICAL REVERSE CHARACTERISTICS

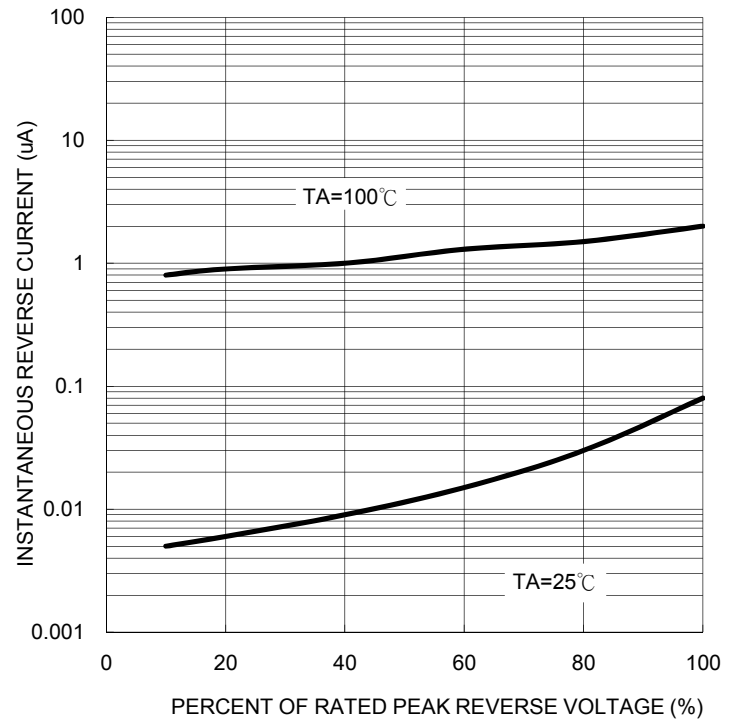

FIG. 3 MAXIMUM NON-REPETITIVE FORWARD SURGE CURRENT

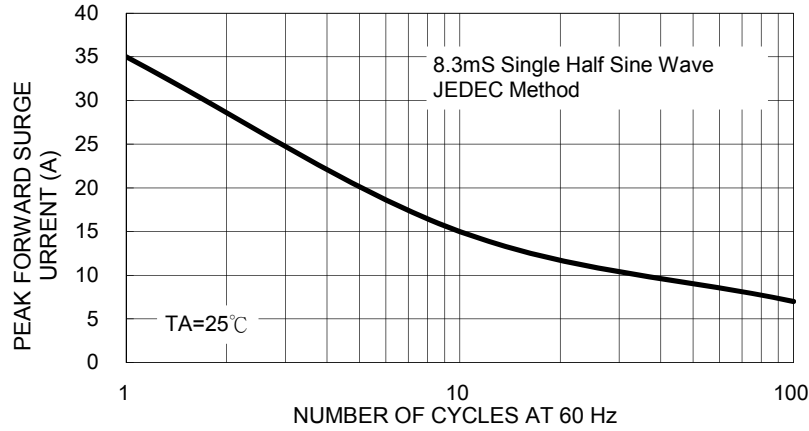

FIG. 5 TYPICAL FORWARD CHARACTERISTICS

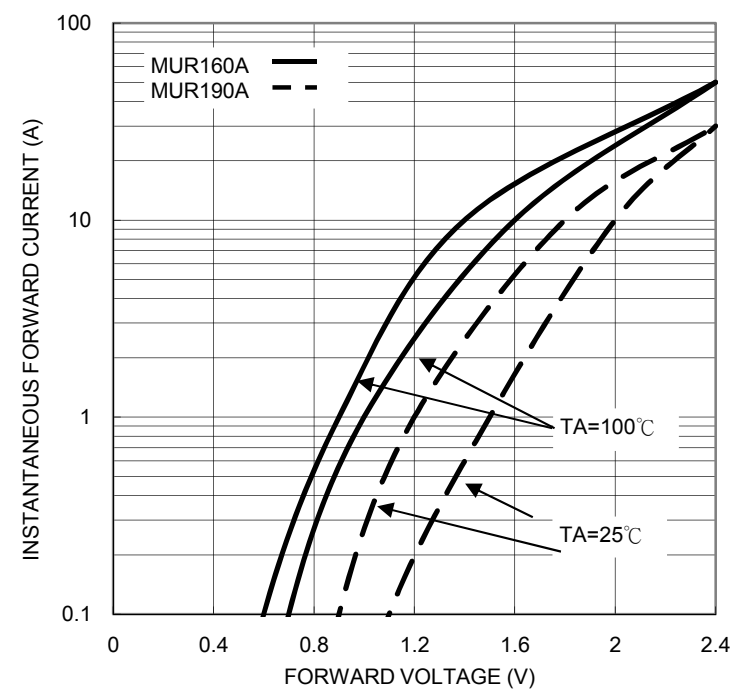

FIG. 4 TYPICAL JUNCTION CAPACITANCE

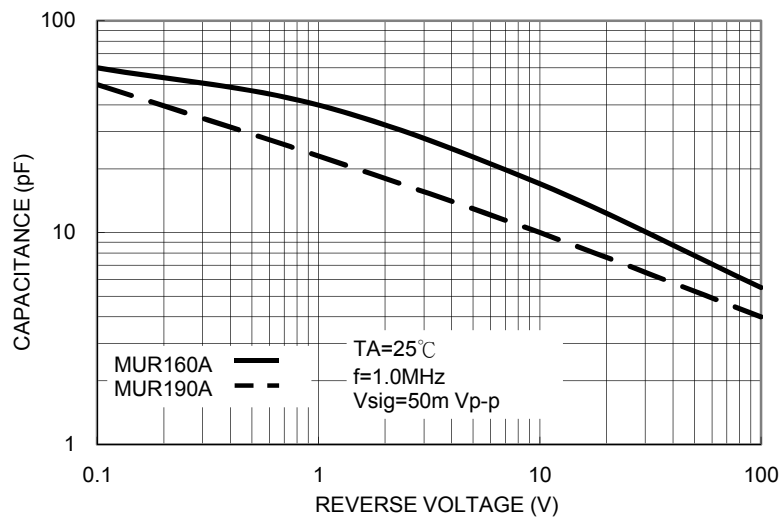
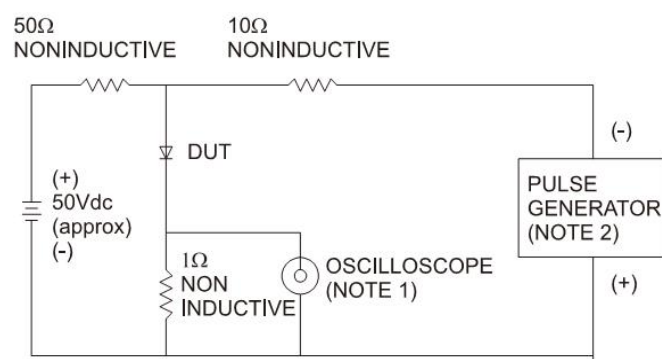
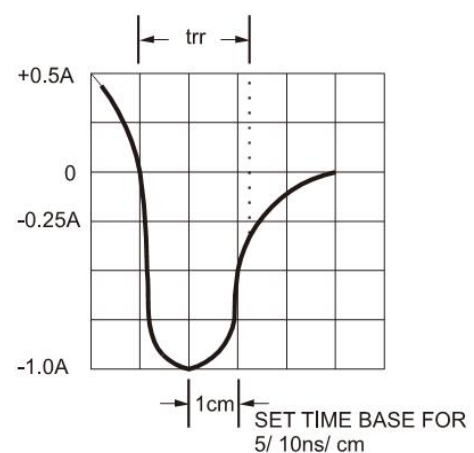

FIG.6- REVERSE RECOVERY TIME CHARACTERISTIC AND TEST CIRCUIT DIAGRAM



NOTES: 1. Rise Time=7ns max. Input Impedance= 1 megohm 22pf
2. Rise Time=10ns max. Source Impedance= 50 ohms



Ordering information

Part No.	Package	Packing	INNER TAPE	Packing code	Packing code (Green)
MUR1x0A	DO-41	3K / AMMO box	52mm	A0	A0G
	DO-41	3K / AMMO box	26mm	A1	A1G
	DO-41	5K / 13" Reel	52mm	R0	R0G
	DO-41	5K / 13" Reel	52mm	R1	R1G
	DO-41	1K / Bulk packing		B0	B0G

Note: "x" is Device Code from "6" thru "9".

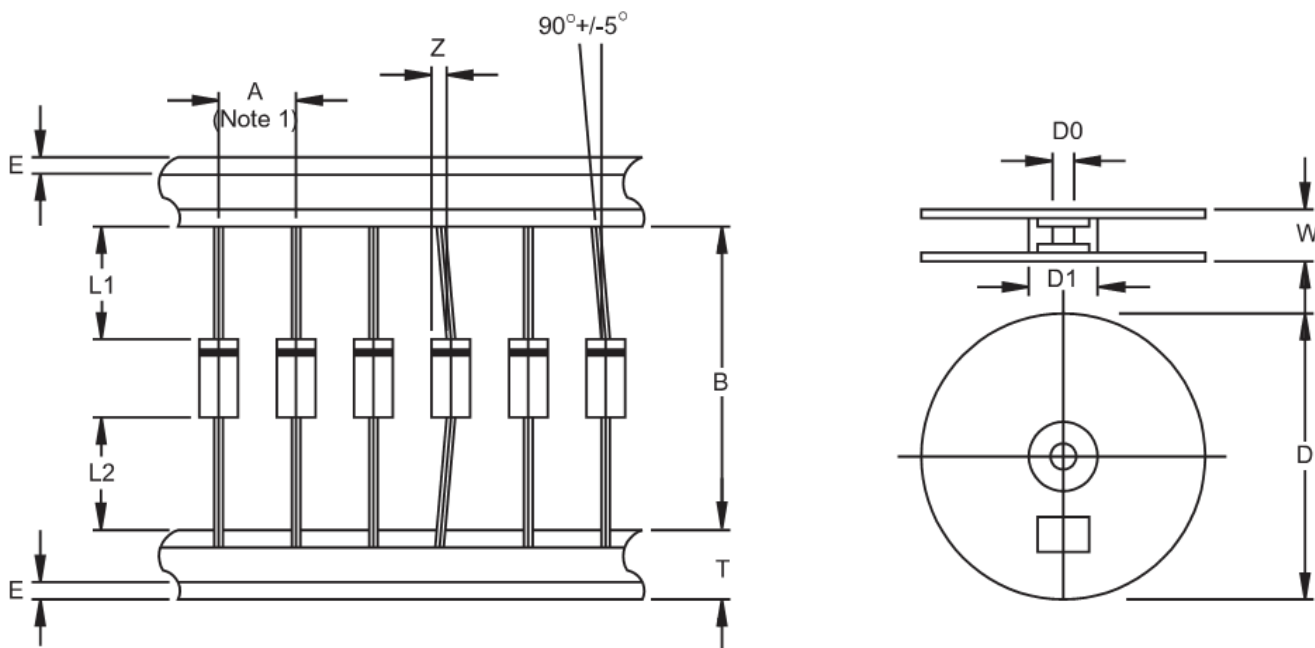
AXIAL LEAD TAPING SPECIFICATIONS

Outline	A	B	Z	T	E	L1-L2	D	D1	D0	W
	±0.5	±1.5	MAX	±0.4	MAX	MAX		±0.3	±0.4	±1.0
DO-41	5	26	1.2	6	0.8	1	330	85.7	16.6	76
DO-41	5	52.4	1.2	6	0.8	1	330	85.7	16.6	76

Unit (mm)

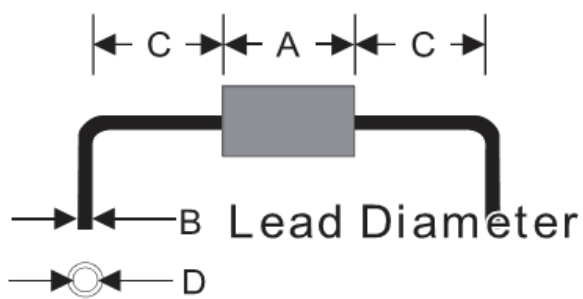
Suggested Mounting Hole Rule

Symbol	Unit(mm)
A	5.1
B	0.8
C	3.0
D	1.2

Dimensions

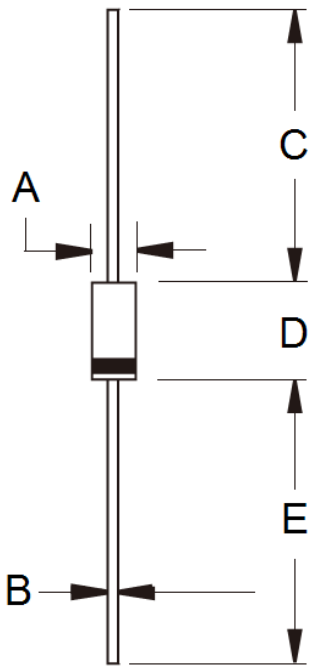

DIM.	Unit(mm)		Unit(inch)	
	Min	Max	Min	Max
A	2.00	2.70	0.079	0.106
B	0.71	0.86	0.028	0.034
C	25.40	-	1.000	-
D	4.20	5.20	0.165	0.205
E	25.40	-	1.000	-

Marking Diagram



- P/N = Specific Device Code
- G = Green Compound
- YWW = Date Code
- F = Factory Code