

FCT FAMILY GENERAL CHARACTERISTICS

DC ELECTRICAL CHARACTERISTICS OVER OPERATING RANGE

$T_A = 0^\circ\text{C}$ to $+70^\circ\text{C}$ $V_{CC} = 5.0\text{V} \pm 5\%$ Min = 4.75V Max = 5.25V (Commercial)

$T_A = -55^\circ\text{C}$ to $+125^\circ\text{C}$ $V_{CC} = 5.0\text{V} \pm 10\%$ Min = 4.50V Max = 5.50V (Military), $V_{LC} = 0.2\text{V}$ $V_{HC} = V_{CC} - 0.2\text{V}$

SYMBOL	PARAMETER	TEST CONDITIONS ¹	MIN	TYP ²	MAX	UNIT	
V_{IH}	Input HIGH Level	Guaranteed Logic High Level	2.0	—	—	V	
V_{IL}	Input LOW Level	Guaranteed Logic Low Level	—	—	0.8	V	
I_{IH}	Input HIGH Current	$V_{CC} = \text{Max}$, $V_{IN} = V_{CC}$	—	—	5	μA	
I_{IL}	Input LOW Current	$V_{CC} = \text{Max}$, $V_{IN} = \text{GND}$	—	—	-5	μA	
I_{OS}	Short Circuit Current	$V_{CC} = \text{Max}$ ³	-60	-120	—	mA	
V_H	Hysteresis	Inputs		0.4		V	
V_{IK}	Input Clamp Voltage	$V_{CC} = \text{Min}$	$I_{IN} = -18\text{mA}$			-1.2	V
			$I_{IN} = 18\text{mA}$			$V_{CC} + 1.2$	V
I_{OZ}	High Impedance Output Current	$V_{CC} = \text{Max}$ $V_O = V_{CC}$ or Gnd	Output Only			± 10	μA
			Bidirectional			± 15	μA
V_{OH}	Output HIGH Voltage	$V_{CC} = 3\text{V}$, $V_{IN} = V_{LC}$ or V_{HC}	$I_{OH} = 32\mu\text{A}$	V_{HC}	V_{CC}	—	V
			$I_{OH} = -300\mu\text{A}$	V_{HC}	V_{CC}	—	
			$I_{OH} = -12\text{mA Mil}$ ⁵	2.4	4.3	—	
			$I_{OH} = -15\text{mA Comm}$ ⁵	2.4	4.3	—	
V_{OL}	Output LOW Voltage	$V_{CC} = 3\text{V}$, $V_{IN} = V_{LC}$ or V_{HC}	$I_{OL} = 300\mu\text{A}$	—	GND	V_{LC}	V
			$I_{OL} = 300\mu\text{A}$	—	GND	V_{LC}	
			$I_{OL} = 32\text{mA Mil}$	—	0.3	0.5	
			$I_{OL} = 48\text{mA Comm}$	—	0.3	0.5	
V_{OH}^4	Output HIGH Voltage	$V_{CC} = 3\text{V}$, $V_{IN} = V_{LC}$ or V_{HC}	$I_{OH} = 32\mu\text{A}$	V_{HC}	V_{CC}	—	V
			$I_{OH} = -300\mu\text{A}$	V_{HC}	V_{CC}	—	
			$I_{OH} = -12\text{mA Mil}$ ⁵	2.4	4.3	—	
			$I_{OH} = -15\text{mA Comm}$ ⁵	2.4	4.3	—	
V_{OL}^4	Output LOW Voltage	$V_{CC} = 3\text{V}$, $V_{IN} = V_{LC}$ or V_{HC}	$I_{OL} = 300\mu\text{A}$	—	GND	V_{LC}	V
			$I_{OL} = 300\mu\text{A}$	—	GND	V_{LC}	
			$I_{OL} = 48\text{mA Mil}$	—	0.3	0.55	
			$I_{OL} = 64\text{mA Comm}$	—	0.3	0.55	

Notes:

- For conditions shown as max. or min., use appropriate value specified under Electrical Characteristics for the applicable device type.
- Typical values are at $V_{CC} = 5.0\text{V}$, $+25^\circ\text{C}$ ambient and maximum loading.
- Not more than one output should be shorted at one time. Duration of the short circuit test should not exceed one second.
- FCT240, FCT244, FCT245, FCT640, FCT645 only.
- $I_{OH} = -24\text{mA}$ also available.

FCT FAMILY GENERAL CHARACTERISTICS

ABSOLUTE MAXIMUM RATING ¹

SYMBOL	RATING	COMMERCIAL	MILITARY	UNIT
V _{TERM}	Terminal Voltage with Respect to GND	-0.5 to +7.0	-0.5 to +7.0	V
T _A	Operating Temperature	0 to +70	-55 to +125	°C
T _{BIAS}	Temperature Under Bias	-55 to +125	-65 to +135	°C
T _{STG}	Storage Temperature	-55 to +125	-65 to +150	°C
I _{OUT}	DC Output Current	120	120	mA

Note 1: Maximum ratings are those values beyond which damage to the device may occur.

RECOMMENDED OPERATING CONDITIONS

SYMBOL	PARAMETER	Min		Typ		Max		UNIT
		Mil	Comm	Mil	Comm	Mil	Comm	
V _{CC}	Supply Voltage	4.5	4.75	5.0	5.0	5.5	5.25	V
T _A	Operating Free-Air Temp	-55	0			125	70	°C
t _r , t _f	Input, Rise and Fall Time			3	3			ns
V _{IH}	High Level Input Voltage	2.0	2.0			V _{CC} +0.5		V
V _{IL}	Low Level Input Voltage	0.5	-0.5			0.8	0.8	V

POWER SUPPLY CHARACTERISTICS

V _{LC} = 0.2V; V _{HC} = V _{CC} - 0.2V									
SYMBOL	PARAMETER	TEST CONDITIONS ⁽¹⁾				MIN	TYP ⁽²⁾	MAX	UNIT
I _{CCQ}	Quiescent Power Supply Current	V _{CC} = Max. V _{IN} ≥ V _{HC} ; V _{IN} ≤ V _{LC} ; f _{CP} = f _i = 0				—	0.001	1.5	mA
I _{CC_T}	Quiescent Power Supply Current TTL Inputs HIGH	V _{CC} = Max. ⁽³⁾ V _{IN} = 3.4V				—	0.5	1.6	mA
I _{CCD}	Dynamic Power Supply Current	V _{CC} = Max., Outputs Open, \overline{OE} = GND One Bit Toggling, 50% Duty Cycle ⁽⁵⁾		V _{IN} ≥ V _{HC} V _{IN} ≤ V _{LC}		—	0.15	0.25	mA/ MHz

Notes:

1. For conditions shown as max. or min. use appropriate value specified under Electrical Characteristics for the applicable device type

2. Typical values are at V_{CC} = 5.0V, +25°C ambient and maximum loading

3. Per TTL driven input (V_{IN} = 3.4V); all other inputs at V_{CC} or GND.

4. I_{CC} = I_{QUIESCENT} + I_{INPUTS} + I_{DYNAMIC}

$$I_{CC} = I_{CCQ} + I_{CC_T} D_H + I_{CCD} (f_{CP}/2 + f_i N_i)$$

I_{CCQ} = Quiescent Current

I_{CC_T} = Power supply current for TTL high input (V_{IN} = 3.4V)

D_H = Duty cycle for TTL inputs high

N_T = Number of TTL inputs at D_H

I_{CCD} = Dynamic current caused by an input transition pair (HLH or LHL)

f_{CP} = Clock frequency for register devices (zero for non-register devices)

f_i = Input frequency

N_i = Number of inputs at f_i

5. "Catch all" = if CE is low, to make toggle

All currents are in milliamps and all frequencies are in megahertz.

TEST CIRCUIT OUTPUT TESTS

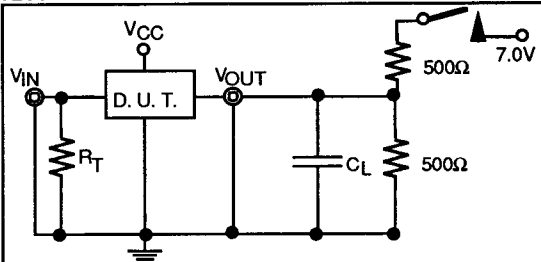

TEST	SWITCH
t_{PLZ}	Closed
t_{PZL}	Closed
All Others	Open

C_L = Load Capacitance includes jig and probe capacitance
 R_T = Termination should be equal to Z_{OUT} of pulse generators
 V_{IN} = 0 to 3V
 Input = $t_r = t_f \leq 2.5ns$ (10% to 90%)

SETUP AND HOLD TIME WAVEFORMS
FOR FLIP FLOPS

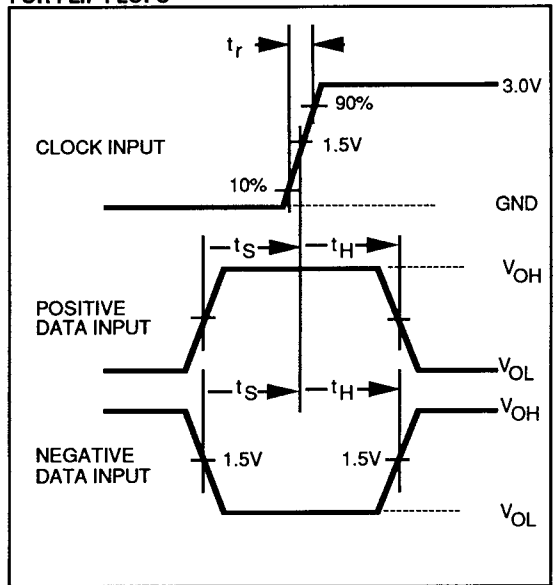

FCT FAMILY
DATA SHEETS

3-STATE OUTPUT ENABLE AND DISABLE WAVEFORMS

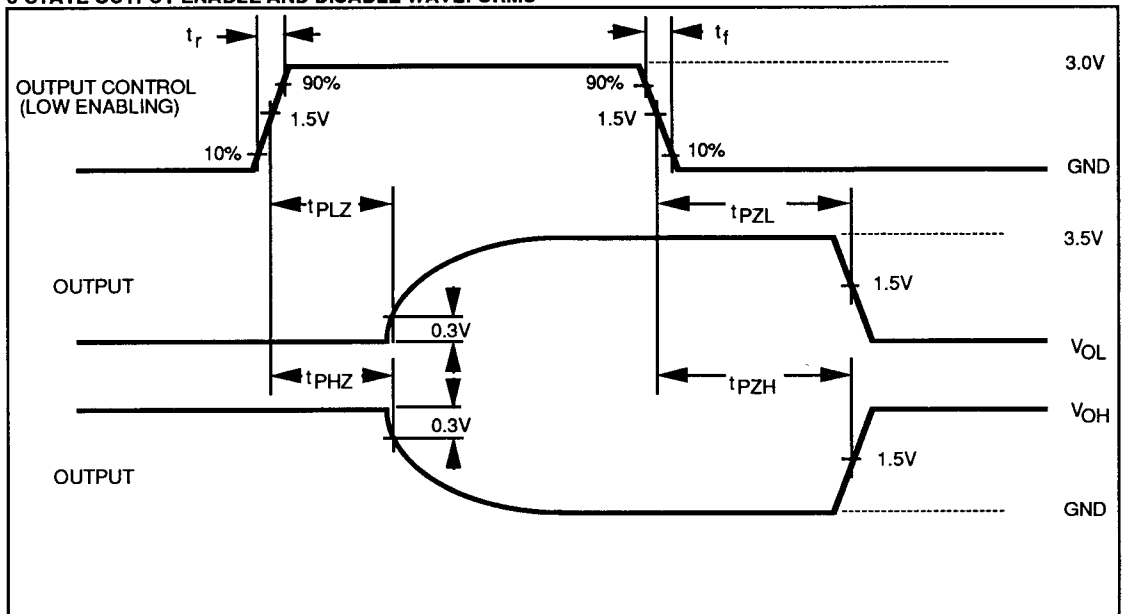

FCT FAMILY
GENERAL CHARACTERISTICS

PROPAGATION DELAY WAVEFORMS

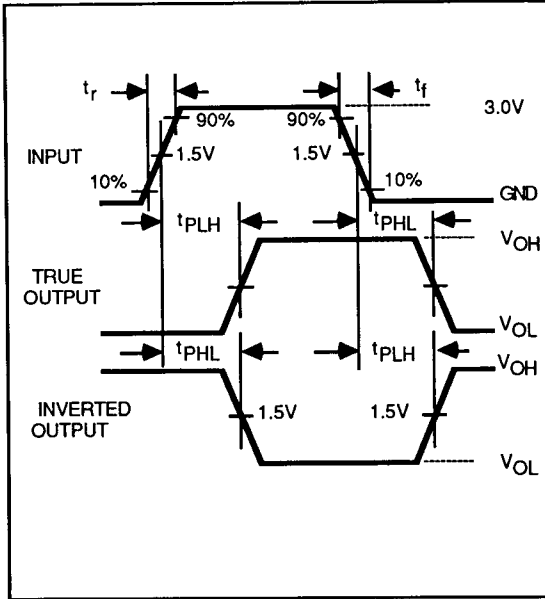

OUTPUT TRANSITION TIME WAVEFORMS
(10-90% of 3.0V)

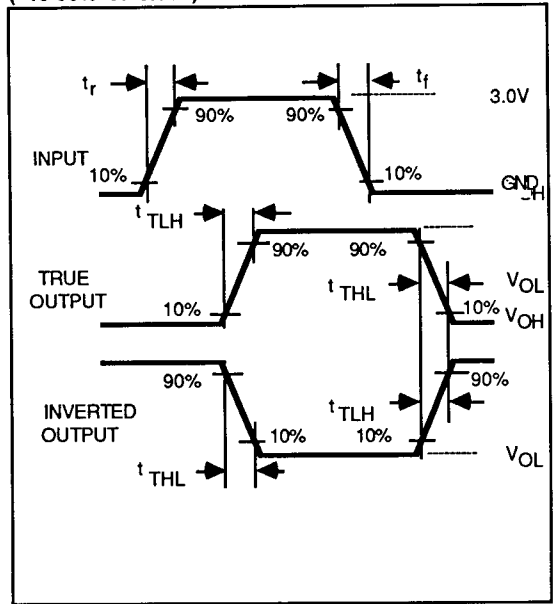

INPUT PULSE WIDTH WAVEFORMS

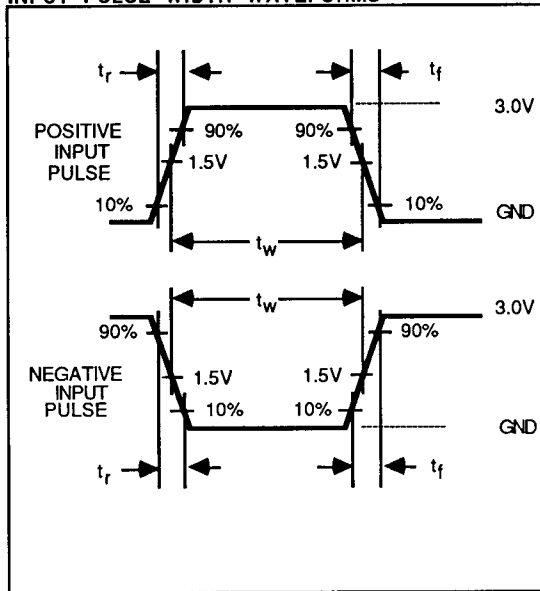

SETUP AND HOLD TIME WAVEFORMS
FOR LATCHES

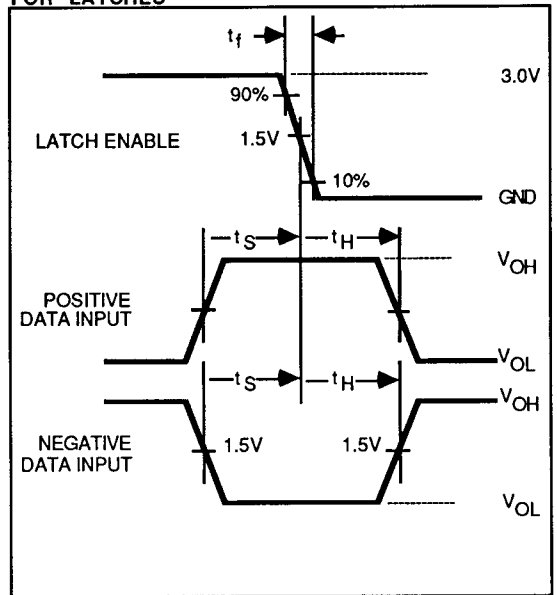

FCT FAMILY
DATA SHEETS

PACKAGING

T-90-20

VTC offers a wide variety of industry-standard packages for its products. These include plastic and ceramic dual in-line, side brazed ceramic, plastic small outline, plastic leaded chip carrier, ceramic leadless chip carrier, surface mount plastic, ceramic flatpacks and pin grid array packages.

Pin counts to 172 pins are used in volume manufacturing and pin counts up to 300 are in development.

The packages dimensions given in this section are offered for VTC's advanced CMOS logic products. The ACL products are available compliant to MIL-STD-883.

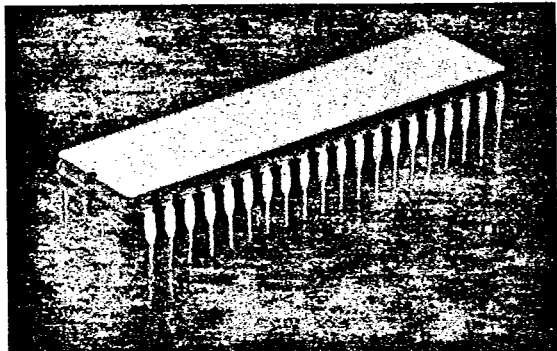

Ceramic DIP (Cerdip)

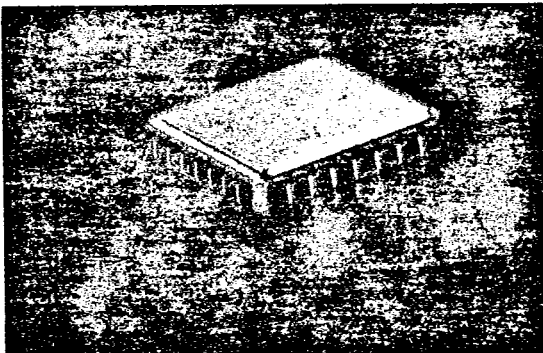

Ceramic Leadless Chip Carrier (LCC)

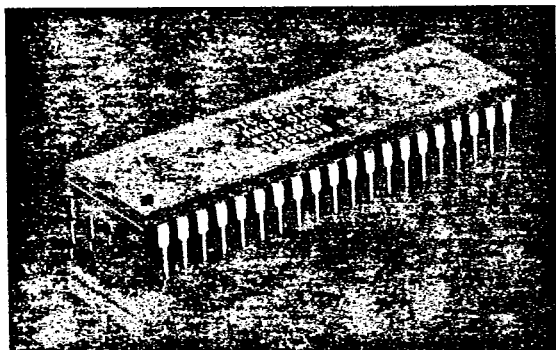

Plastic DIP

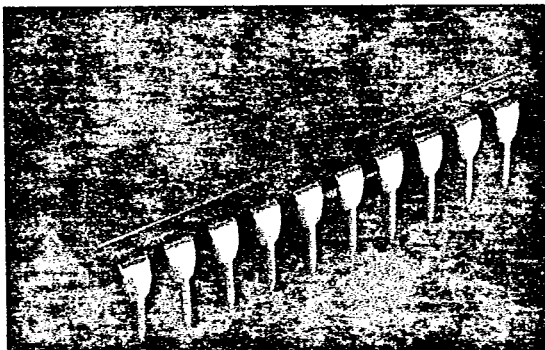

Plastic Slimline DIP

PACKAGING AND ORDERING

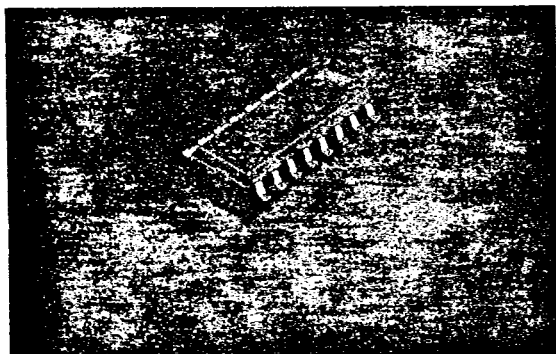

Plastic SOIC

CERAMIC DIP (CERDIP)

T-90-20

20 PIN CERAMIC DIP				
SYMBOL	INCHES		MILLIMETERS	
	MIN.	MAX.	MIN.	MAX.
A	0.155	0.200	3.94	5.08
B	0.014	0.023	0.36	0.58
C	0.008	0.015	0.20	0.38
D	0.940	0.960	23.87	24.39
E	0.220	0.300	5.59	7.62
F	0.300 BSC		7.62 BSC	
G	0.030	0.070	0.76	1.78
H	0.100 BSC		2.54 BSC	
J	0.015	0.060	0.38	1.52
K	0.125	0.200	3.18	5.08
L	0°	15°	0°	15°

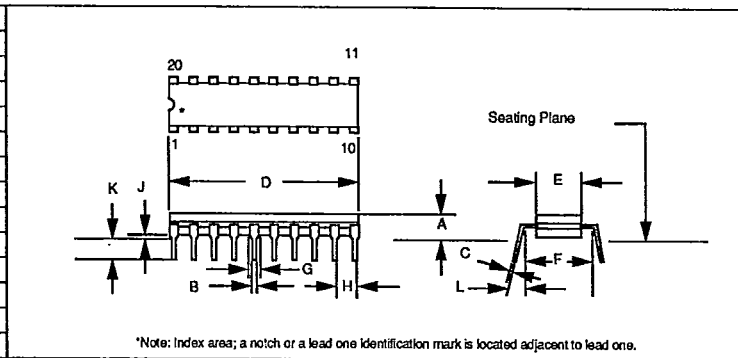

24 PIN CERAMIC DIP				
SYMBOL	INCHES		MILLIMETERS	
	MIN.	MAX.	MIN.	MAX.
A	0.155	0.200	3.94	5.08
B	0.014	0.023	0.36	0.58
C	0.008	0.015	0.20	0.38
D	1.150	1.350	29.21	34.29
E	0.220	0.300	5.59	7.62
F	0.300 BSC		7.62 BSC	
G	0.030	0.070	0.76	1.78
H	0.100 BSC		2.54 BSC	
J	0.015	0.060	0.38	1.52
K	0.125	0.200	3.18	5.08
L	0°	15°	0°	15°

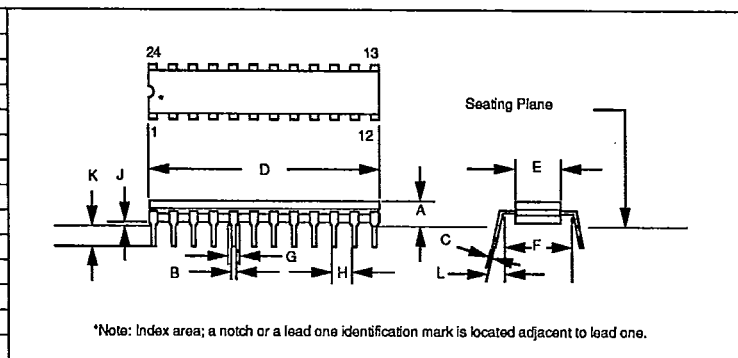

PACKAGING AND ORDERING

CERAMIC LEADLESS CHIP CARRIER (LCC)

T-90-20

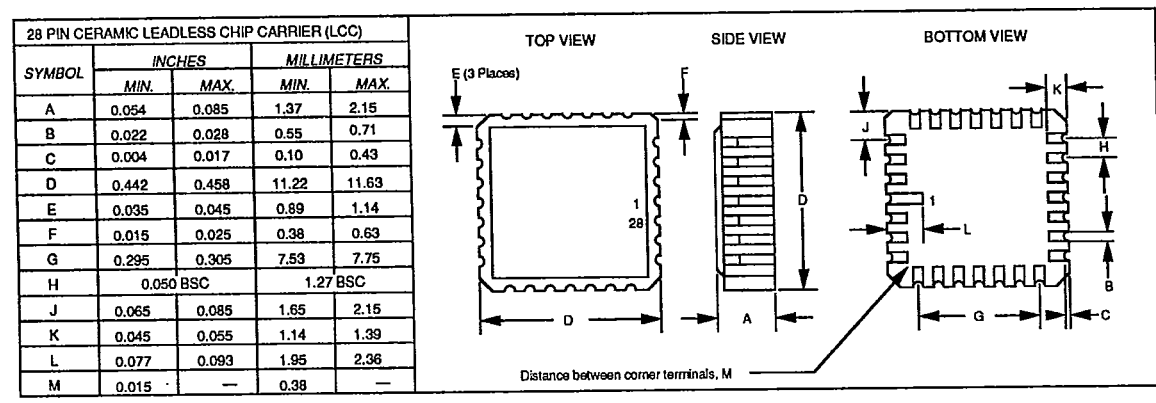
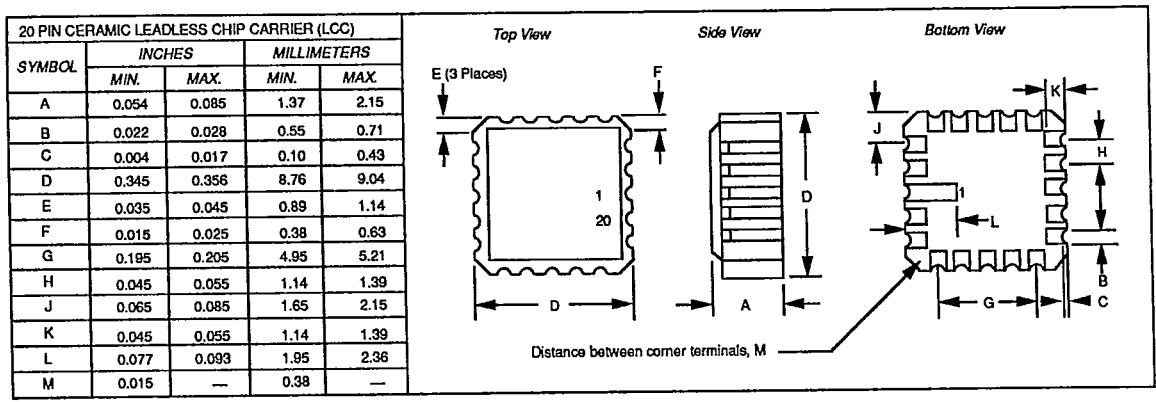

PACKAGING AND ORDERING

T-90 -20

20 PIN PLASTIC DIP				
SYMBOL	INCHES		MILLIMETERS	
	MIN.	MAX.	MIN.	MAX.
A	—	0.210	—	5.33
B	0.014	0.022	0.356	0.558
C	0.008	0.015	0.204	0.381
D	0.925	1.060	23.5	26.9
E	0.240	0.280	6.10	7.11
F	0.300	0.325	7.62	8.25
G	0.045	0.070	1.15	1.77
H	0.100 BSC		2.54 BSC	
J	0.015	—	0.39	—
K	0.115	0.160	2.93	4.06
L	Ø	15°	Ø	15°

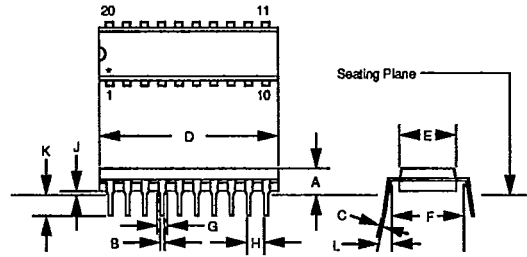

*Note: Index area; a notch or a lead one identification mark is located adjacent to lead one.

PACKAGING
AND ORDERING

PLASTIC SLIMLINE DIP

T-90-20

24 PIN 'SLIMLINE' PLASTIC DIP				
SYMBOL	INCHES		MILLIMETERS	
	MIN.	MAX.	MIN.	MAX.
A	—	0.210	—	5.33
B	0.014	0.022	0.356	0.558
C	0.008	0.015	0.204	0.381
D	1.125	1.275	29.3	32.3
E	0.240	0.280	6.10	7.11
F	0.300 BSC		7.62 BSC	
G	0.045	0.070	1.15	1.77
H	0.100 BSC		2.54 BSC	
J	0.015	—	0.39	—
K	0.115	0.160	2.93	4.06
L	0°	15°	0°	15°

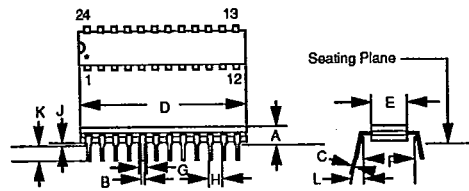

*Note: Index area; a notch or a lead one identification mark is located adjacent to lead one.

PACKAGING AND ORDERING

T-90-20

20 PIN SOIC				
SYMBOL	INCHES		MILLIMETERS	
	MIN.	MAX.	MIN.	MAX.
A	0.092	0.110	2.35	2.75
B	0.009	0.030	0.25	0.75
C	0.007	0.013	0.18	0.32
D	0.496	0.512	12.60	13.00
E	0.291	0.300	7.40	7.60
F	0.393	0.420	10.00	10.65
G	0.013	0.020	0.35	0.49
H	0.050 BSC		1.27 BSC	
J	0.003	0.012	0.10	0.30
K	0.015	0.050	0.40	1.27
L	Ø	Ø	Ø	Ø

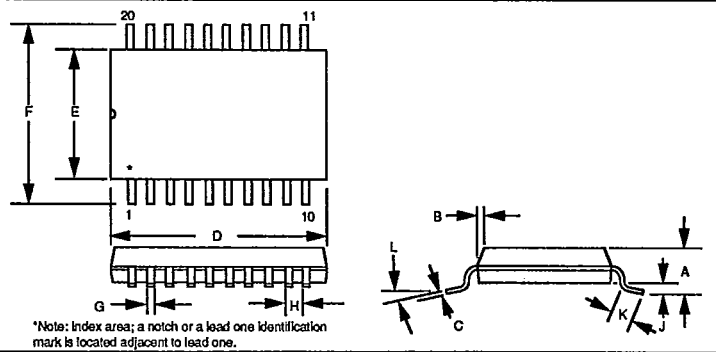

24 PIN SOIC				
SYMBOL	INCHES		MILLIMETERS	
	MIN.	MAX.	MIN.	MAX.
A	0.092	0.110	2.35	2.75
B	0.009	0.030	0.25	0.75
C	0.007	0.013	0.18	0.32
D	0.598	0.615	15.20	15.62
E	0.291	0.300	7.40	7.60
F	0.393	0.420	10.00	10.65
G	0.013	0.020	0.35	0.49
H	0.050 BSC		1.27 BSC	
J	0.003	0.012	0.10	0.30
K	0.015	0.050	0.40	1.27
L	Ø	Ø	Ø	Ø

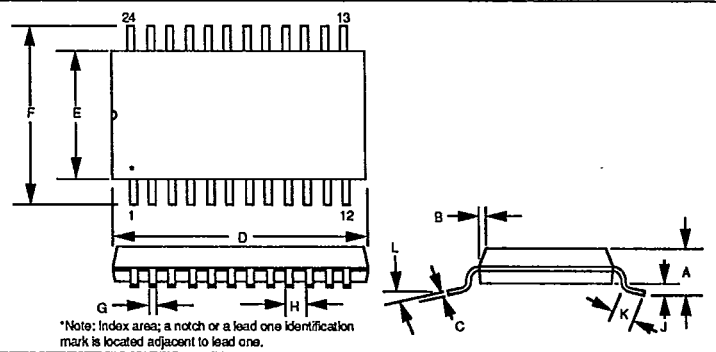

PACKAGING AND ORDERING