



3.3V CMOS 16-BIT BUFFER/DRIVER WITH 3-STATE OUTPUTS AND 5 VOLT TOLERANT I/O

IDT74LVC162244A

FEATURES:

- Typical $t_{sk(o)}$ (Output Skew) < 250ps
- ESD > 2000V per MIL-STD-883, Method 3015; > 200V using machine model (C = 200pF, R = 0)
- $V_{CC} = 3.3V \pm 0.3V$, Normal Range
- $V_{CC} = 2.7V$ to $3.6V$, Extended Range
- CMOS power levels (0.4 μ W typ. static)
- All inputs, outputs, and I/O are 5V tolerant
- Available in SSOP, TSSOP, and TVSOP packages

DRIVE FEATURES:

- Balanced Output Drivers: $\pm 12mA$
- Low switching noise

APPLICATIONS:

- 5V and 3.3V mixed voltage systems
- Data communication and telecommunication systems

DESCRIPTION:

The LVC162244A 16-bit buffer/driver is built using advanced dual metal CMOS technology. The LVC162244A is designed specifically to improve both the performance and density of 3-state memory address drivers, clock drivers, and bus-oriented receivers and transmitters. The device can be used as four 4-bit buffers, two 8-bit buffers, or one 16-bit buffer. This device provides true outputs and symmetrical active-low output-enable (\overline{OE}) inputs.

All pins of this 16-bit buffer/driver can be driven from either 3.3V or 5V devices. This feature allows the use of the device as a translator in a mixed 3.3V/5V supply system.

The LVC162244A has series resistors in the device output structure which will significantly reduce line noise when used with light loads. This driver has been developed to drive $\pm 12mA$ at the designated threshold levels.

FUNCTIONAL BLOCK DIAGRAM

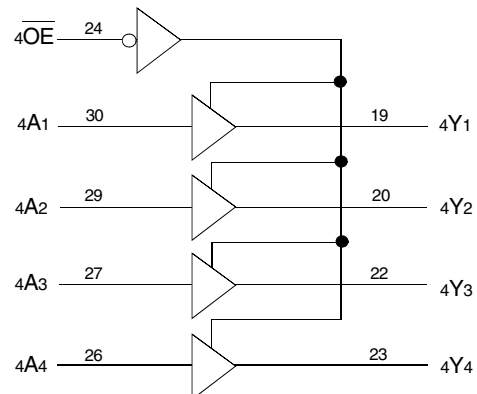
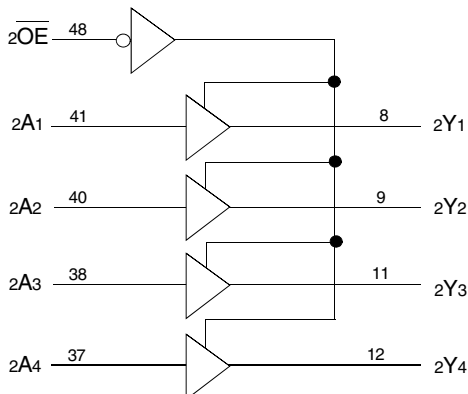
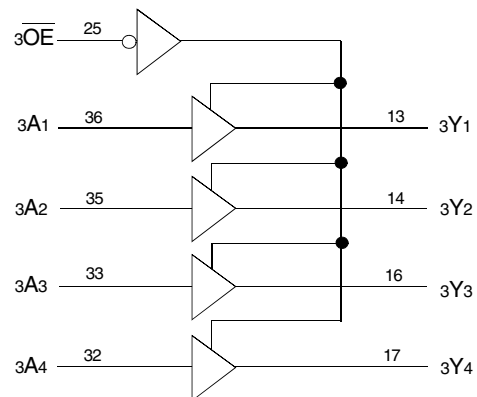
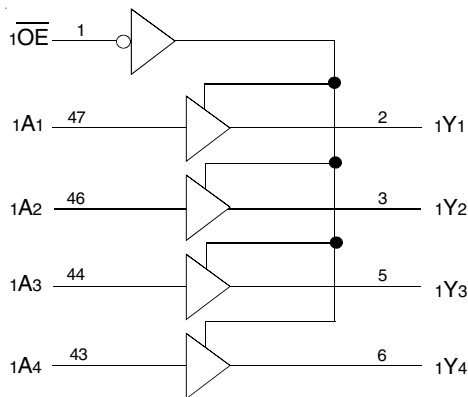

The IDT logo is a registered trademark of Integrated Device Technology, Inc.

INDUSTRIAL TEMPERATURE RANGE

JUNE 2006

PIN CONFIGURATION

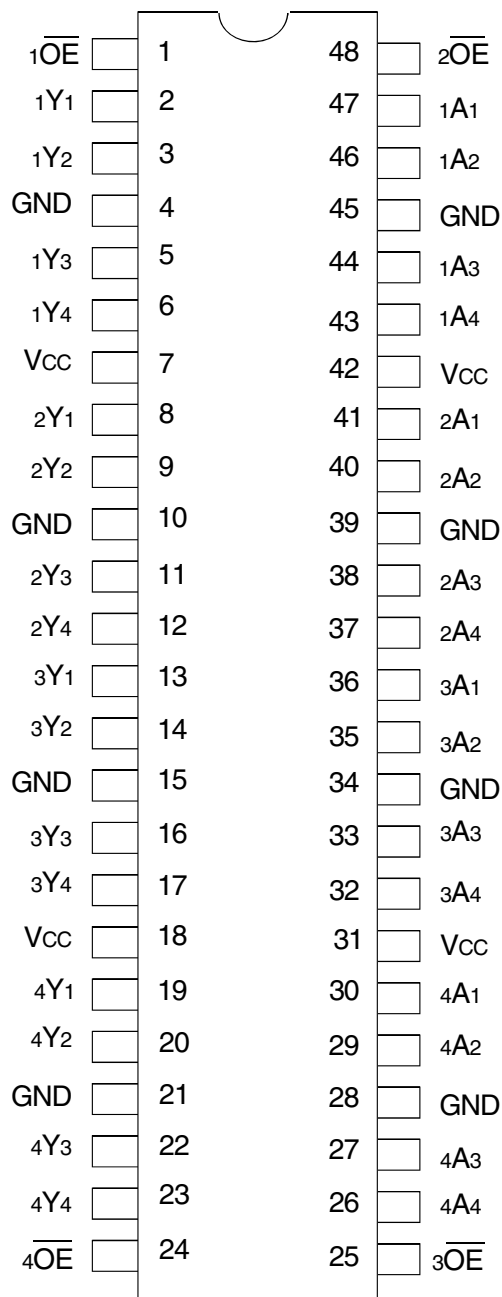

SSOP/ TSSOP/ TVSOP
TOP VIEW

ABSOLUTE MAXIMUM RATINGS⁽¹⁾

Symbol	Description	Max	Unit
VTERM ⁽²⁾	Terminal Voltage with Respect to GND	-0.5 to +6.5	V
VTERM ⁽³⁾	Terminal Voltage with Respect to GND	-0.5 to +6.5	V
TSTG	Storage Temperature	-65 to +150	°C
I _{OUT}	DC Output Current	-50 to +50	mA
I _{IK} I _{OK}	Continuous Clamp Current, V _I < 0 or V _O < 0	-50	mA
I _{CC} I _{SS}	Continuous Current through each V _{CC} or GND	±100	mA

NOTES:

- Stresses greater than those listed under ABSOLUTE MAXIMUM RATINGS may cause permanent damage to the device. This is a stress rating only and functional operation of the device at these or any other conditions above those indicated in the operational sections of this specification is not implied. Exposure to absolute maximum rating conditions for extended periods may affect reliability.
- V_{CC} terminals.
- All terminals except V_{CC}.

CAPACITANCE (T_A = +25°C, F = 1.0MHz)

Symbol	Parameter ⁽¹⁾	Conditions	Typ.	Max.	Unit
C _{IN}	Input Capacitance	V _{IN} = 0V	4.5	6	pF
C _{OUT}	Output Capacitance	V _{OUT} = 0V	6.5	8	pF
C _{I/O}	I/O Port Capacitance	V _{IN} = 0V	6.5	8	pF

NOTE:

- As applicable to the device type.

PIN DESCRIPTION

Pin Names	Description
x \overline{OE}	3-State Output Enable Inputs (Active LOW)
xAx	Data Inputs
xYx	3-State Outputs

FUNCTION TABLE (EACH 4-BIT BUFFER)⁽¹⁾

Inputs		Outputs
x \overline{OE}	xAx	xYx
L	H	H
L	L	L
H	X	Z

NOTE:

- H = HIGH Voltage Level
X = Don't Care
L = LOW Voltage Level
Z = High-Impedance

DC ELECTRICAL CHARACTERISTICS OVER OPERATING RANGE

Following Conditions Apply Unless Otherwise Specified:

Operating Condition: $T_A = -40^{\circ}\text{C}$ to $+85^{\circ}\text{C}$

Symbol	Parameter	Test Conditions		Min.	Typ. ⁽¹⁾	Max.	Unit
V_{IH}	Input HIGH Voltage Level	$V_{CC} = 2.3\text{V}$ to 2.7V		1.7	—	—	V
		$V_{CC} = 2.7\text{V}$ to 3.6V		2	—	—	
V_{IL}	Input LOW Voltage Level	$V_{CC} = 2.3\text{V}$ to 2.7V		—	—	0.7	V
		$V_{CC} = 2.7\text{V}$ to 3.6V		—	—	0.8	
I_{IH} I_{IL}	Input Leakage Current	$V_{CC} = 3.6\text{V}$	$V_I = 0$ to 5.5V	—	—	± 5	μA
I_{OZH} I_{OZL}	High Impedance Output Current (3-State Output pins)	$V_{CC} = 3.6\text{V}$	$V_O = 0$ to 5.5V	—	—	± 10	μA
I_{OFF}	Input/Output Power Off Leakage	$V_{CC} = 0\text{V}$, V_{IN} or $V_O \leq 5.5\text{V}$		—	—	± 50	μA
V_{IK}	Clamp Diode Voltage	$V_{CC} = 2.3\text{V}$, $I_{IN} = -18\text{mA}$		—	-0.7	-1.2	V
V_H	Input Hysteresis	$V_{CC} = 3.3\text{V}$		—	100	—	mV
I_{CCL} I_{CCH} I_{CCZ}	Quiescent Power Supply Current	$V_{CC} = 3.6\text{V}$	$V_{IN} = \text{GND}$ or V_{CC}	—	—	10	μA
			$3.6 \leq V_{IN} \leq 5.5\text{V}^{(2)}$	—	—	10	
ΔI_{CC}	Quiescent Power Supply Current Variation	One input at $V_{CC} - 0.6\text{V}$, other inputs at V_{CC} or GND		—	—	500	μA

NOTES:

- Typical values are at $V_{CC} = 3.3\text{V}$, $+25^{\circ}\text{C}$ ambient.
- This applies in the disabled state only.

OUTPUT DRIVE CHARACTERISTICS

Symbol	Parameter	Test Conditions ⁽¹⁾		Min.	Max.	Unit
V_{OH}	Output HIGH Voltage	$V_{CC} = 2.3\text{V}$ to 3.6V	$I_{OH} = -0.1\text{mA}$	$V_{CC} - 0.2$	—	V
		$V_{CC} = 2.3\text{V}$	$I_{OH} = -4\text{mA}$	1.9	—	
			$I_{OH} = -6\text{mA}$	1.7	—	
		$V_{CC} = 2.7\text{V}$	$I_{OH} = -4\text{mA}$	2.2	—	
			$I_{OH} = -8\text{mA}$	2	—	
		$V_{CC} = 3\text{V}$	$I_{OH} = -6\text{mA}$	2.4	—	
$I_{OH} = -12\text{mA}$	2		—			
V_{OL}	Output LOW Voltage	$V_{CC} = 2.3\text{V}$ to 3.6V	$I_{OL} = 0.1\text{mA}$	—	0.2	V
		$V_{CC} = 2.3\text{V}$	$I_{OL} = 4\text{mA}$	—	0.4	
			$I_{OL} = 6\text{mA}$	—	0.55	
		$V_{CC} = 2.7\text{V}$	$I_{OL} = 4\text{mA}$	—	0.4	
			$I_{OL} = 8\text{mA}$	—	0.6	
		$V_{CC} = 3\text{V}$	$I_{OL} = 6\text{mA}$	—	0.55	
$I_{OL} = 12\text{mA}$	—		0.8			

NOTE:

- V_{IH} and V_{IL} must be within the min. or max. range shown in the DC ELECTRICAL CHARACTERISTICS OVER OPERATING RANGE table for the appropriate V_{CC} range. $T_A = -40^{\circ}\text{C}$ to $+85^{\circ}\text{C}$.

OPERATING CHARACTERISTICS, $T_A = 25^\circ\text{C}$

Symbol	Parameter	Test Conditions	Typical	Unit
CPD	Power Dissipation Capacitance per Buffer/Driver Outputs enabled	$C_L = 0\text{pF}$, $f = 10\text{MHz}$	35	pF
CPD	Power Dissipation Capacitance per Buffer/Driver Outputs disabled		4	

SWITCHING CHARACTERISTICS⁽¹⁾

Symbol	Parameter	$V_{CC} = 2.7\text{V}$		$V_{CC} = 3.3\text{V} \pm 0.3\text{V}$		Unit
		Min.	Max.	Min.	Max.	
t_{PLH} t_{PHL}	Propagation Delay xAX to xYx	—	5.6	1.1	4.4	ns
t_{PZH} t_{PZL}	Output Enable Time x $\overline{\text{OE}}$ to xYx	—	6.9	1	5.5	ns
t_{PHZ} t_{PLZ}	Output Disable Time x $\overline{\text{OE}}$ to xYx	—	6.8	1.8	6.3	ns
$t_{SK(0)}$	Output Skew ⁽²⁾	—	—	—	500	ps

NOTES:

1. See TEST CIRCUITS AND WAVEFORMS. $T_A = -40^\circ\text{C}$ to $+85^\circ\text{C}$.
2. Skew between any two outputs of the same package and switching in the same direction.

TEST CIRCUITS AND WAVEFORMS

TEST CONDITIONS

Symbol	V _{CC} ⁽¹⁾ =3.3V±0.3V	V _{CC} ⁽¹⁾ =2.7V	V _{CC} ⁽²⁾ =2.5V±0.2V	Unit
V _{LOAD}	6	6	2 x V _{CC}	V
V _{IH}	2.7	2.7	V _{CC}	V
V _T	1.5	1.5	V _{CC} / 2	V
V _{LZ}	300	300	150	mV
V _{HZ}	300	300	150	mV
C _L	50	50	30	pF

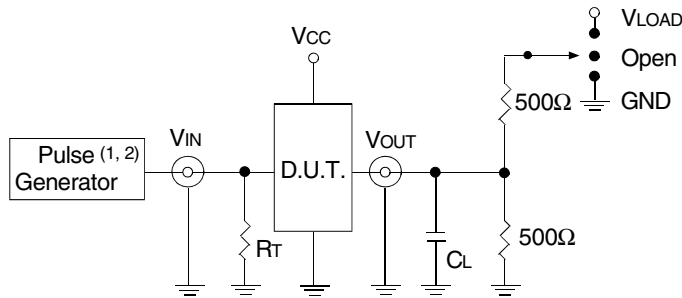

Test Circuit for All Outputs

DEFINITIONS:

C_L = Load capacitance: includes jig and probe capacitance.
R_T = Termination resistance: should be equal to Z_{OUT} of the Pulse Generator.

NOTES:

1. Pulse Generator for All Pulses: Rate ≤ 10MHz; t_F ≤ 2.5ns; t_R ≤ 2.5ns.
2. Pulse Generator for All Pulses: Rate ≤ 10MHz; t_F ≤ 2ns; t_R ≤ 2ns.

SWITCH POSITION

Test	Switch
Open Drain Disable Low Enable Low	V _{LOAD}
Disable High Enable High	GND
All Other Tests	Open

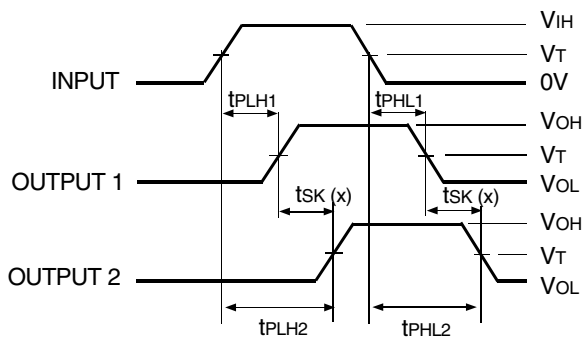

$$tsk(x) = |t_{PLH2} - t_{PLH1}| \text{ or } |t_{PHL2} - t_{PHL1}|$$

Output Skew - tsk(x)

NOTES:

1. For tsk(o) OUTPUT1 and OUTPUT2 are any two outputs.
2. For tsk(b) OUTPUT1 and OUTPUT2 are in the same bank.

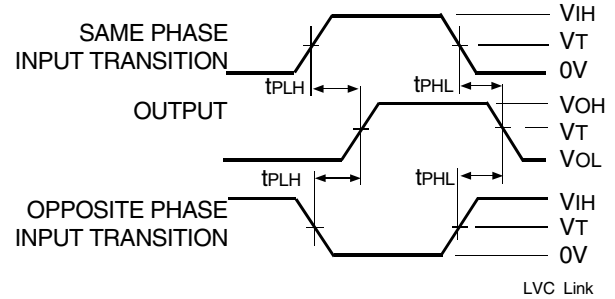

Propagation Delay

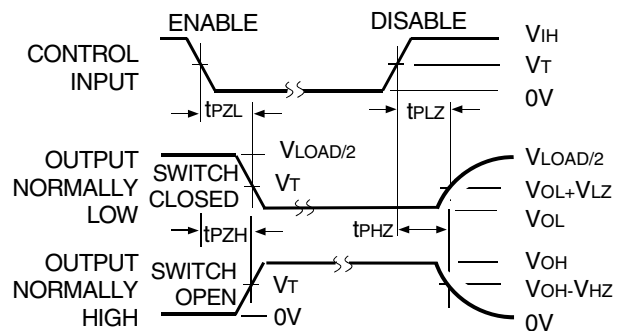

Enable and Disable Times

NOTE:

1. Diagram shown for input Control Enable-LOW and input Control Disable-HIGH.

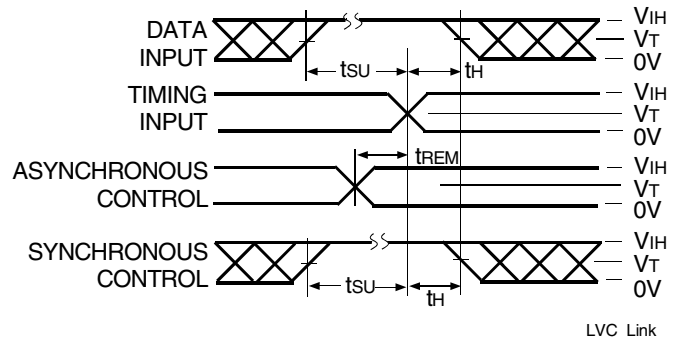

Set-up, Hold, and Release Times



Pulse Width

ORDERING INFORMATION

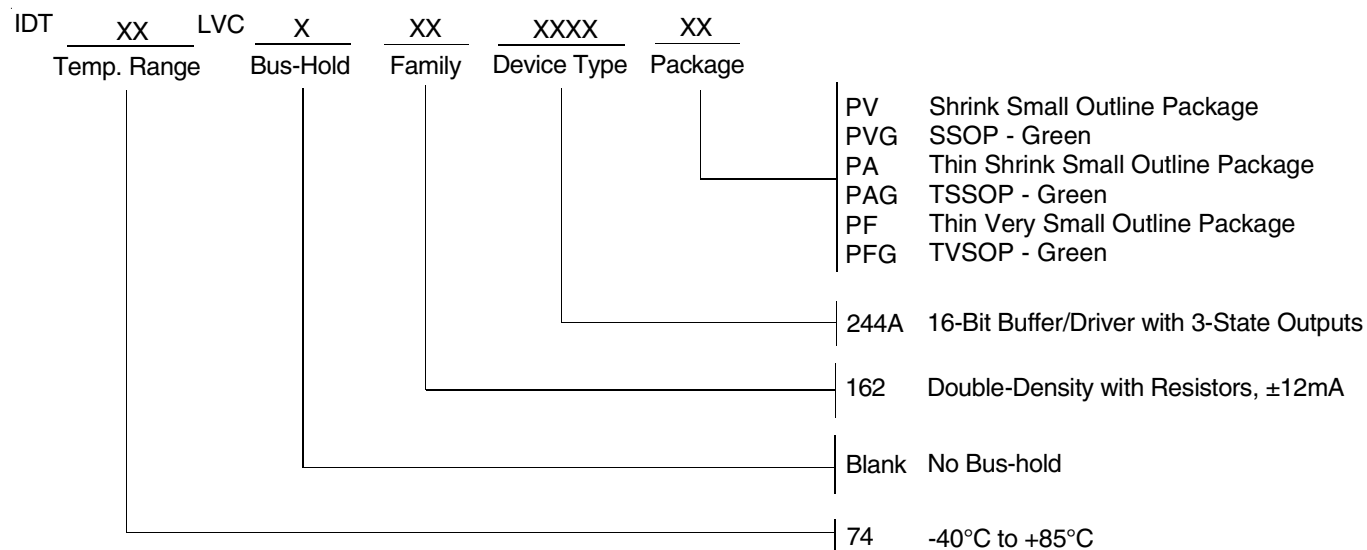

CORPORATE HEADQUARTERS
 6024 Silver Creek Valley Road
 San Jose, CA 95138

for SALES:
 800-345-7015 or 408-284-8200
 fax: 408-284-2775
 www.idt.com

for Tech Support:
 logichelp@idt.com