



## MC4558

### LINEAR INTEGRATED CIRCUIT

## DUAL OPERATIONAL AMPLIFIER

### DESCRIPTION

The UTC **MC4558** is a monolithic integrated circuit designed for dual operational amplifier.

### FEATURES

- \* No frequency compensation required
- \* No latch-up
- \* Large common mode and differential voltage range
- \* Parameter tracking over temperature range
- \* Gain and phase match between amplifiers
- \* Internally frequency compensated
- \* Low noise input transistors

### ORDERING INFORMATION

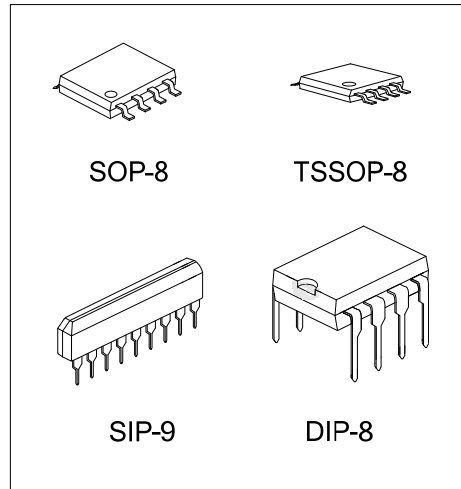

Normal	Ordering Number		Package	Packing
	Lead Free Plating	Halogen Free		
MC4558-D08-T	MC4558L-D08-T	MC4558G-D08-T	DIP-8	Tube
MC4558-P08-R	MC4558L-P08-R	MC4558G-P08-R	TSSOP-8	Tape Reel
MC4558-S08-T	MC4558L-S08-T	MC4558G-S08-T	SOP-8	Tube
MC4558-S08-R	MC4558L-S08-R	MC4558G-S08-R	SOP-8	Tape Reel
MC4558-G09-T	MC4558L-G09-T	MC4558G-G09-T	SIP-9	Tube

<p>MC4558L-D08-T</p> <p>(1) Packing Type (2) Package Type (3) Lead Plating</p>	<p>(1) R: Tape Reel, T: Tube (2) D08: DIP-8, P08: TSSOP-8, S08: SOP-8, G09: SIP-9 (3) L: Lead Free Plating, Blank: Pb/Sn, G: Halogen Free</p>
--	---

### ■ PIN CONFIGURATIONS

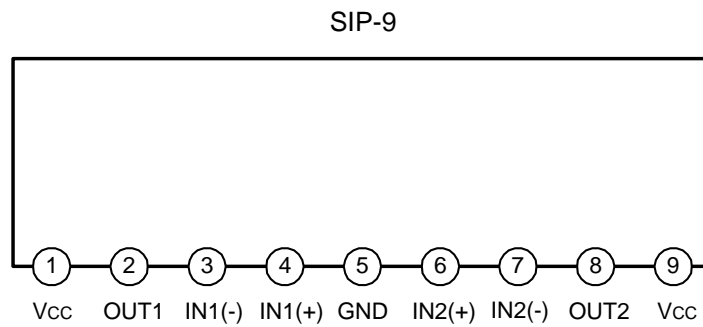
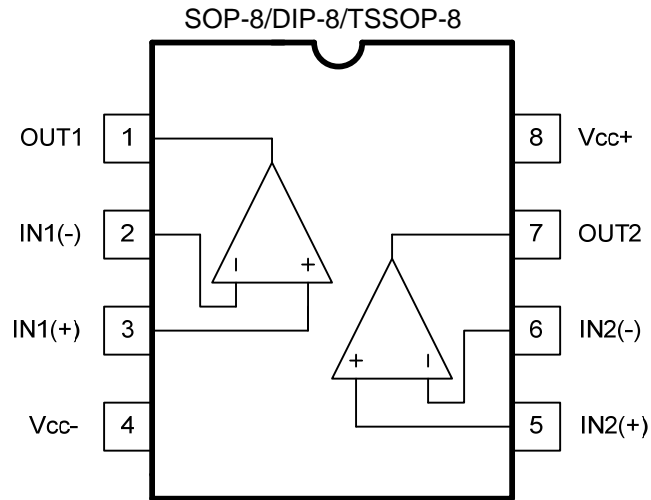

■ BLOCK DIAGRAM

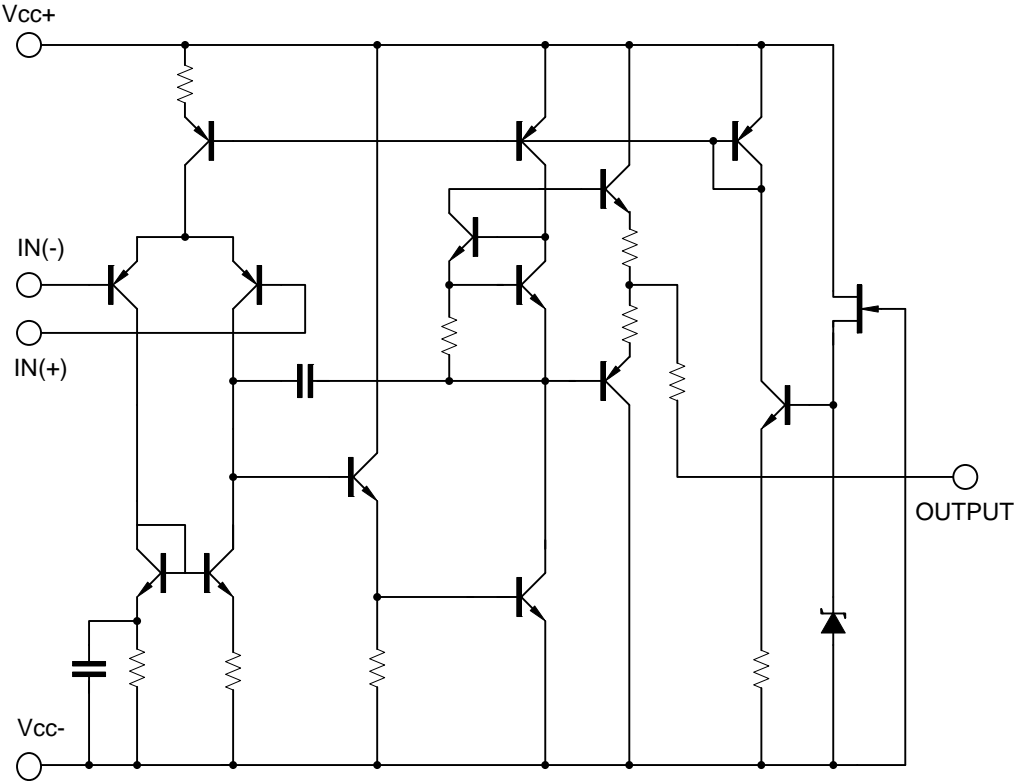

### ■ ABSOLUTE MAXIMUM RATINGS

PARAMETER	SYMBOL	RATING	UNIT	
Supply Voltage	$V_{CC}$	$\pm 22$	V	
Differential input voltage	$V_{I(DIFF)}$	$\pm 18$	V	
Power Dissipation	$P_D$	DIP-8	600	mW
		SOP-8	400	mW
		TSSOP-8	250	mW
		SIP-9	500	mW
Input Voltage	$V_{IN}$	$\pm 15$	V	
Junction Temperature	$T_J$	+125	°C	
Operating Temperature	$T_{OPR}$	-20 ~ +85	°C	
Storage Temperature	$T_{STG}$	-40 ~ +150	°C	

Note 1. Absolute maximum ratings are those values beyond which the device could be permanently damaged. Absolute maximum ratings are stress ratings only and functional device operation is not implied.

2. The device is guaranteed to meet performance specification within 0°C ~ +70°C operating temperature range and assured by design from -20°C ~ +85°C.

### ■ ELECTRICAL CHARACTERISTICS (Ta=25°C, VCC=15V, Vee=-15V)

PARAMETER	SYMBOL	TEST CONDITIONS	MIN	TYP	MAX	UNIT
Supply Current, all Amp, no load	$I_{CC}$			2.3	4.5	mA
Input offset voltage	$V_{I(OFF)}$	$R_S < 10k\Omega$		2	6	mV
Input offset current	$I_{I(OFF)}$			5	200	nA
Input bias current	$I_{I(BIAS)}$			30	500	nA
Large signal voltage gain	$G_V$	$V_o(p-p) = \pm 10V, R_L \cong 2k\Omega$	20	200		V/mV
Common Mode Input Voltage Range	$V_{I(COM)}$		$\pm 12$	$\pm 13$		V
Common Mode Rejection Ratio	$RR_{(COM)}$	$R_S \cong 10k\Omega$	70	90		dB
Supply Voltage Rejection Ratio	$RR_{(VCC)}$	$R_S \cong 10k\Omega$	76	90		dB
Output Voltage swing	$V_{O(p-p)}$	$R_L \geq 10k\Omega$	$\pm 12$	$\pm 14$		V
Power Consumption	$P_C$			70	170	mW
Slew Rate	SR	$V_{IN} = \pm 10V, R_L \cong 2k\Omega, C_L \cong 100pF$	1.2	2.2		V/ $\mu s$
Rise Time	$T_{RIS}$	$V_{IN} = \pm 20mV, R_L \cong 2k\Omega, C_L \cong 100pF$		0.3		$\mu s$
Overshoot	OS	$V_{IN} = \pm 20mV, R_L \cong 2k\Omega, C_L \cong 100pF$		15		%
Input Resistance	$R_{IN}$		0.3	2		M $\Omega$
Output Resistance	$R_{OUT}$			75		$\Omega$
Total Harmonic Distortion	THD	$f=1kHz, A_v=20dB, R_L=2k\Omega, V_{OUT}=2V_{pp}, C_L=100pF$		0.008		%
Channel Separation	$V_{O1}/V_{O2}$			120		dB
<b>FREQUENCY CHARACTERISTIC</b>						
Unity Gain Bandwidth	BW		2.0	2.8		MHz

## ■ TYPICAL CHARACTERISTICS

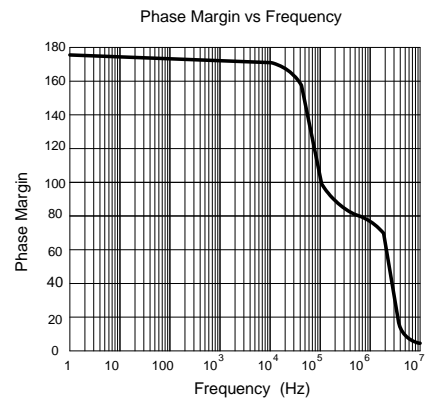
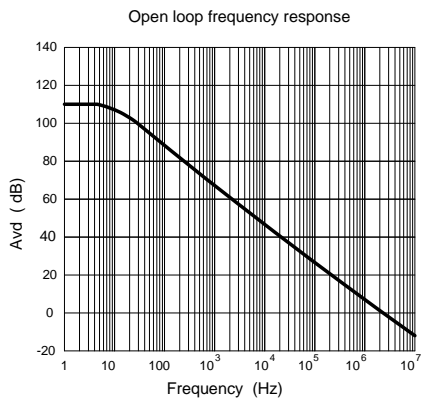
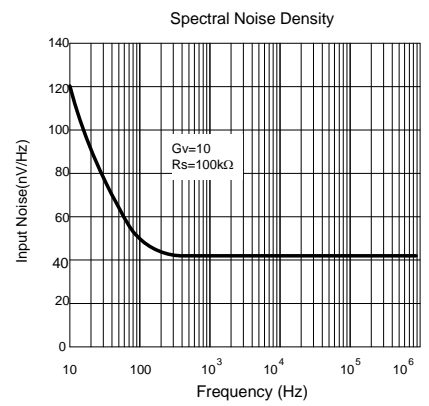
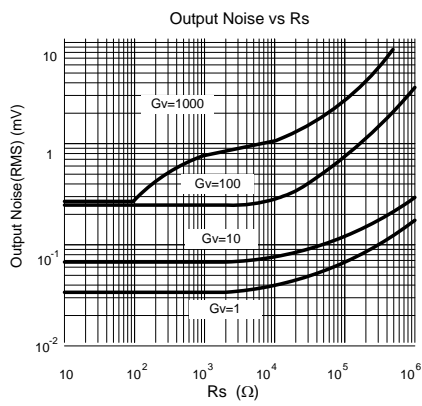
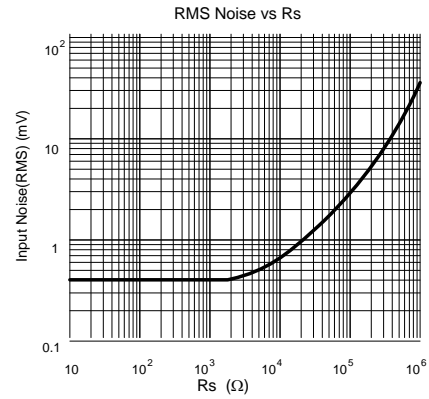
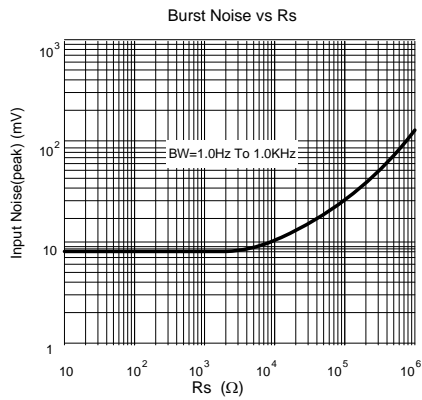

■ TYPICAL CHARACTERISTICS(Cont.)

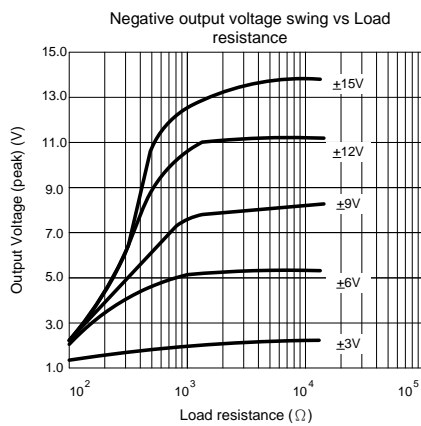
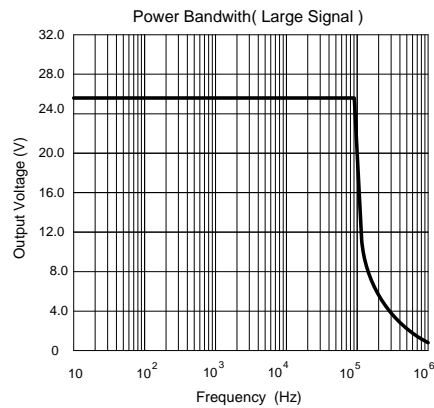
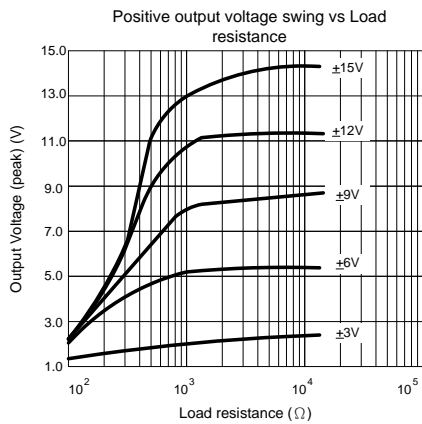

UTC assumes no responsibility for equipment failures that result from using products at values that exceed, even momentarily, rated values (such as maximum ratings, operating condition ranges, or other parameters) listed in products specifications of any and all UTC products described or contained herein. UTC products are not designed for use in life support appliances, devices or systems where malfunction of these products can be reasonably expected to result in personal injury. Reproduction in whole or in part is prohibited without the prior written consent of the copyright owner. The information presented in this document does not form part of any quotation or contract, is believed to be accurate and reliable and may be changed without notice.