

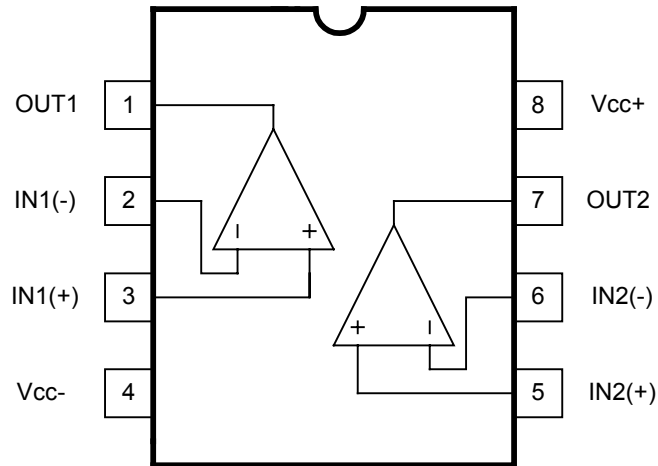

## ■ PIN CONFIGURATION

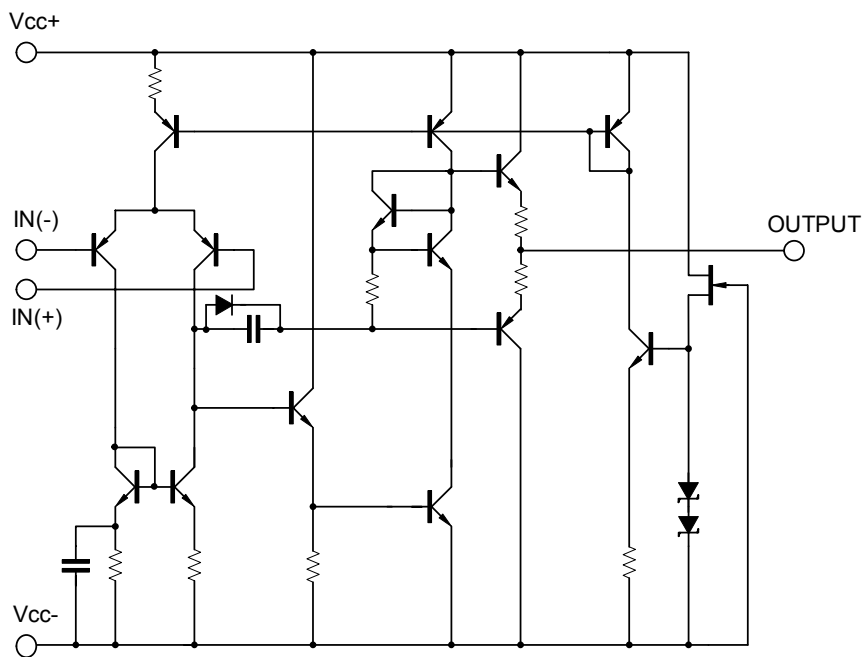

## ■ TEST CIRCUIT



### ■ ABSOLUTE MAXIMUM RATINGS (Ta=25°C)

PARAMETER		SYMBOL	RATINGS	UNIT
Supply Voltage		$V^+/V^-$	±18	V
Input Voltage		$V_{IN}$	±15	V
Differential Input Voltage		$V_{I(DIFF)}$	±30	V
Output Current		$I_{OUT}$	±50	mA
Power Dissipation	SOP-8	$P_D$	300	mW
	DIP-8		800	
	TSSOP-8		250	
	MSOP-8		250	
Junction Temperature		$T_J$	+125	°C
Operating Temperature		$T_{OPR}$	-40~+85	°C
Storage Temperature		$T_{STG}$	-40~+125	°C

Note Absolute maximum ratings are those values beyond which the device could be permanently damaged. Absolute maximum ratings are stress ratings only and functional device operation is not implied.

### ■ ELECTRICAL CHARACTERISTICS (V+ /V- = ±15V, Ta=25°C)

PARAMETER	SYMBOL	TEST CONDITION	MIN	TYP	MAX	UNIT
Input Offset Voltage	$V_{I(OFF)}$	$R_S \cong 10k\Omega$	-	0.5	3	mV
Input Offset Current	$I_{I(OFF)}$		-	5	200	nA
Input Bias Current	$I_{I(BIAS)}$		-	100	500	nA
Large Signal Voltage Gain	$G_V$	$V_{OUT} = \pm 10V, R_L \cong 2k\Omega$	90	110	-	dB
Output Voltage Swing	$V_{OM}$	$R_L \cong 2k\Omega$	±12	±13.5	-	V
Input Common Mode Voltage	$V_{I(CM)}$		±12	±13.5	-	V
Common Mode Rejection Ratio	RR	$R_S \cong 10k\Omega$	80	110	-	dB
Supply Voltage Rejection Ratio	SVR	$R_S \cong 10k\Omega$	80	110	-	dB
Operating Current	$I_{CC}$		-	6	9	mA
Slew Rate	SR	$R_L \cong 2k\Omega$	-	5	-	V/μs
Gain bandwidth Product	GB	f=10KHz	-	15	-	MHz
Total Harmonic Distortion	THD	$G_V = 20dB, V_{OUT} = 5V, R_L = 2k\Omega, f = 1KHz$	-	0.0005	-	%
Input Noise Voltage	eN	RIAA $R_S = 2.2 k\Omega, 30kHzLPF$	-	0.8	-	μVrms

## ■ TYPICAL CHARACTERISTICS

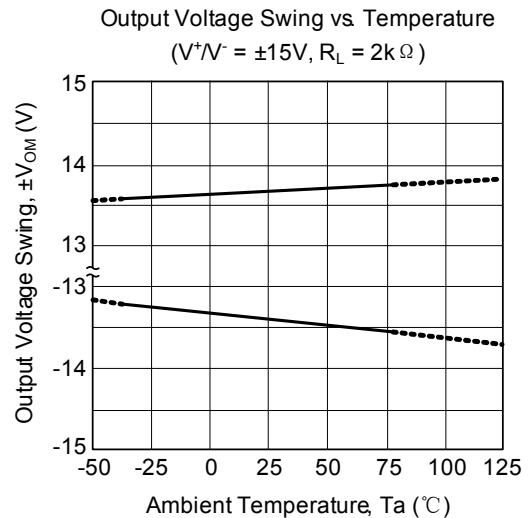
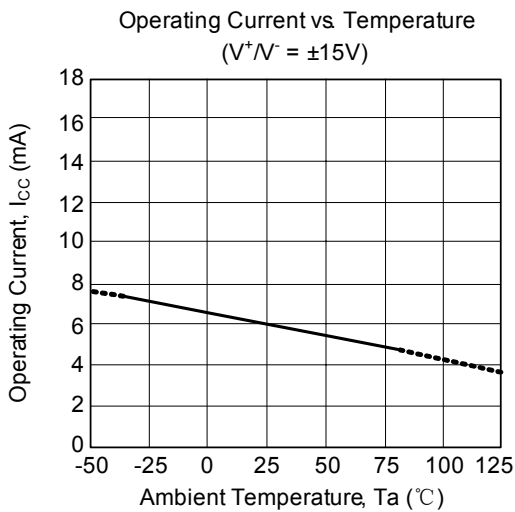
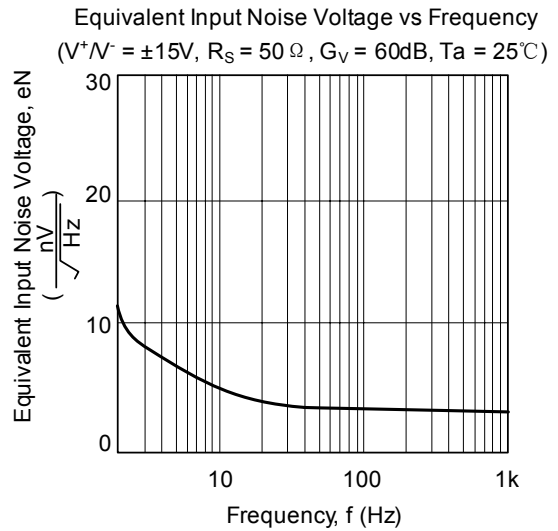
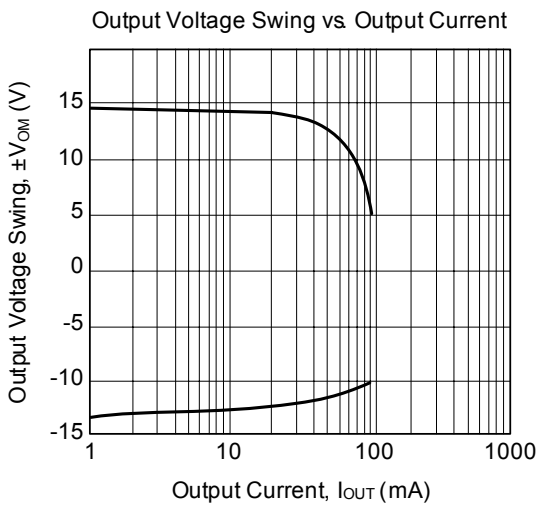
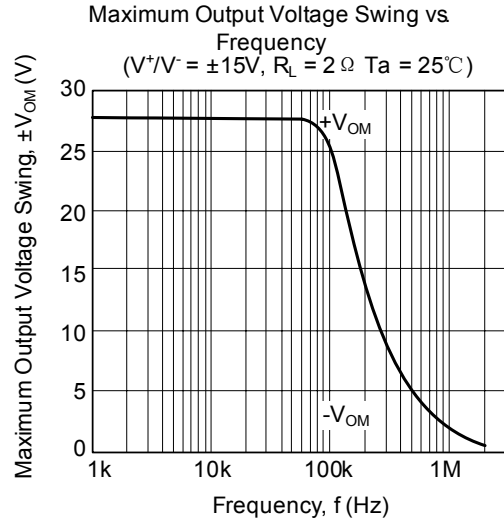
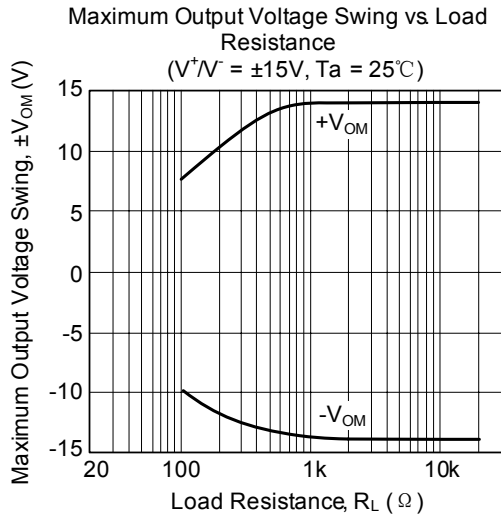

## ■ TYPICAL CHARACTERISTICS(Cont.)

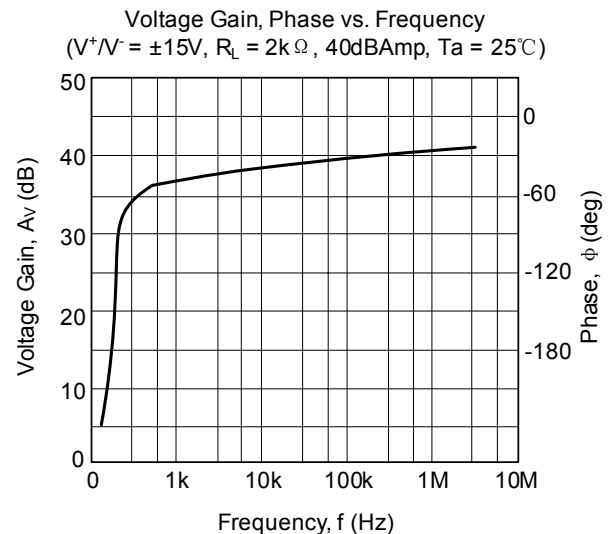
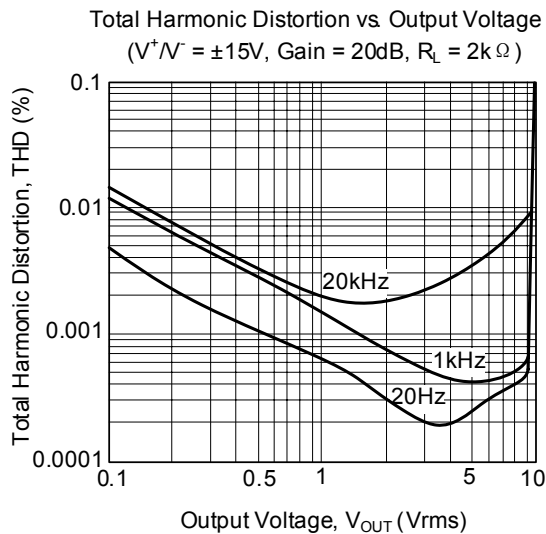
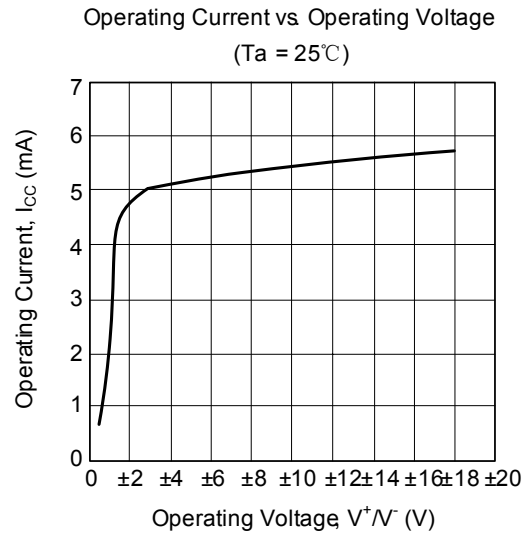
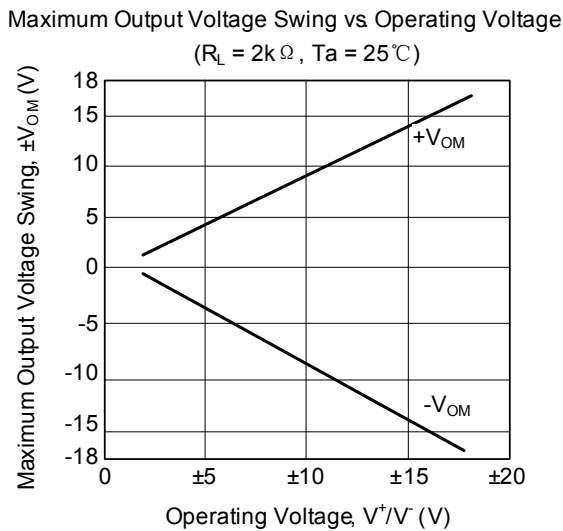
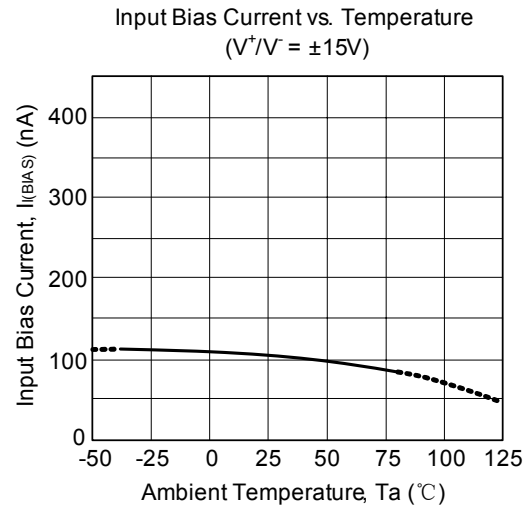
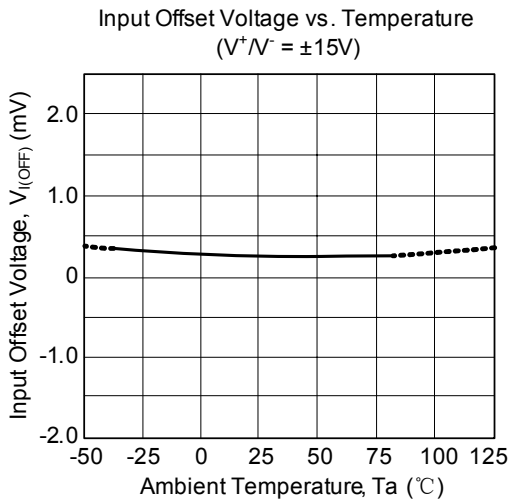

UTC assumes no responsibility for equipment failures that result from using products at values that exceed, even momentarily, rated values (such as maximum ratings, operating condition ranges, or other parameters) listed in products specifications of any and all UTC products described or contained herein. UTC products are not designed for use in life support appliances, devices or systems where malfunction of these products can be reasonably expected to result in personal injury. Reproduction in whole or in part is prohibited without the prior written consent of the copyright owner. The information presented in this document does not form part of any quotation or contract, is believed to be accurate and reliable and may be changed without notice.