

DM7486 Quad 2-Input Exclusive-OR Gates

General Description

This device contains four independent gates each of which performs the logic exclusive-OR function.

Features

- Alternate Military/Aerospace device (5486) is available. Contact a Fairchild Semiconductor Sales Office/Distributor for specifications.

Connection Diagram

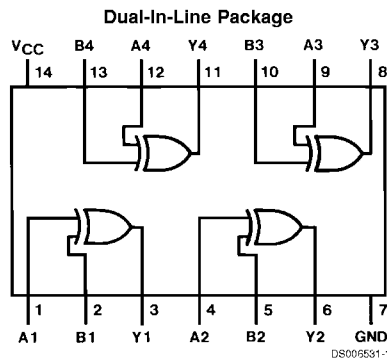

Order Number 5486DMQB, 5486FMQB, DM5486J, DM5486W or DM7486N
See Package Number J14A, N14A or W14B

Function Table

$$Y = A \oplus B$$

Inputs		Output
A	B	Y
L	L	L
L	H	H
H	L	H
H	H	L

H = High Logic Level
L = Low Logic Level

Absolute Maximum Ratings (Note 1)	DM54 and 54	-55°C to +125°C
Supply Voltage	7V	0°C to +70°C
Input Voltage	5.5V	DM74
Operating Free Air Temperature Range	Storage Temperature Range	-65°C to +150°C

Recommended Operating Conditions

Symbol	Parameter	DM5486			DM7486			Units
		Min	Nom	Max	Min	Nom	Max	
V _{CC}	Supply Voltage	4.5	5	5.5	4.75	5	5.25	V
V _{IH}	High Level Input Voltage	2			2			V
V _{IL}	Low Level Input Voltage			0.8			0.8	V
I _{OH}	High Level Output Current			-0.8			-0.8	mA
I _{OL}	Low Level Output Current			16			16	mA
T _A	Free Air Operating Temperature	-55		125	0		70	°C

Note 1: The "Absolute Maximum Ratings" are those values beyond which the safety of the device cannot be guaranteed. The device should not be operated at these limits. The parametric values defined in the "Electrical Characteristics" table are not guaranteed at the absolute maximum ratings. The "Recommended Operating Conditions" table will define the conditions for actual device operation.

Electrical Characteristics

over recommended operating free air temperature range (unless otherwise noted)

Symbol	Parameter	Conditions	Min	Typ (Note 2)	Max	Units
V _I	Input Clamp Voltage	V _{CC} = Min, I _I = -12 mA			-1.5	V
V _{OH}	High Level Output Voltage	V _{CC} = Min, I _{OH} = Max V _{IL} = Max, V _{IH} = Min	2.4	3.4		V
V _{OL}	Low Level Output Voltage	V _{CC} = Min, I _{OL} = Max V _{IH} = Min, V _{IL} = Max		0.2	0.4	V
I _I	Input Current @ Max Input Voltage	V _{CC} = Max, V _I = 5.5V			1	mA
I _{IH}	High Level Input Current	V _{CC} = Max, V _I = 2.4V			40	μA
I _{IL}	Low Level Input Current	V _{CC} = Max, V _I = 0.4V			-1.6	mA
I _{OS}	Short Circuit Output Current	V _{CC} = Max	DM54	-20		mA
		(Note 3)	DM74	-18		
I _{CCH}	Supply Current with Outputs High	V _{CC} = Max	DM54	30	43	mA
			DM74	30	50	
I _{CCL}	Supply Current with Outputs Low	V _{CC} = Max (Note 3)		36	57	mA

Note 2: All typicals are at V_{CC} = 5V, T_A = 25°C.

Note 3: Not more than one output should be shorted at a time.

Note 4: I_{CCH} is measured with all outputs open, one input of each gate at 4.5V, and the other inputs grounded.

Note 5: I_{CCL} is measured with all outputs open, and all inputs at ground.

Switching Characteristics

at $V_{CC} = 5V$ and $T_A = 25^\circ C$ (See Section 1 for Test Waveforms and Output Load)

Symbol	Parameter	Conditions	$C_L = 15\text{ pF}$ $R_L = 400\Omega$		Units
			Min	Max	
t_{PLH}	Propagation Delay Time Low to High Level Output	Other Input Low		23	ns
t_{PHL}	Propagation Delay Time High to Low Level Output			17	ns
t_{PLH}	Propagation Delay Time Low to High Level Output	Other Input High		30	ns
t_{PHL}	Propagation Delay Time High to Low Level Output			22	ns

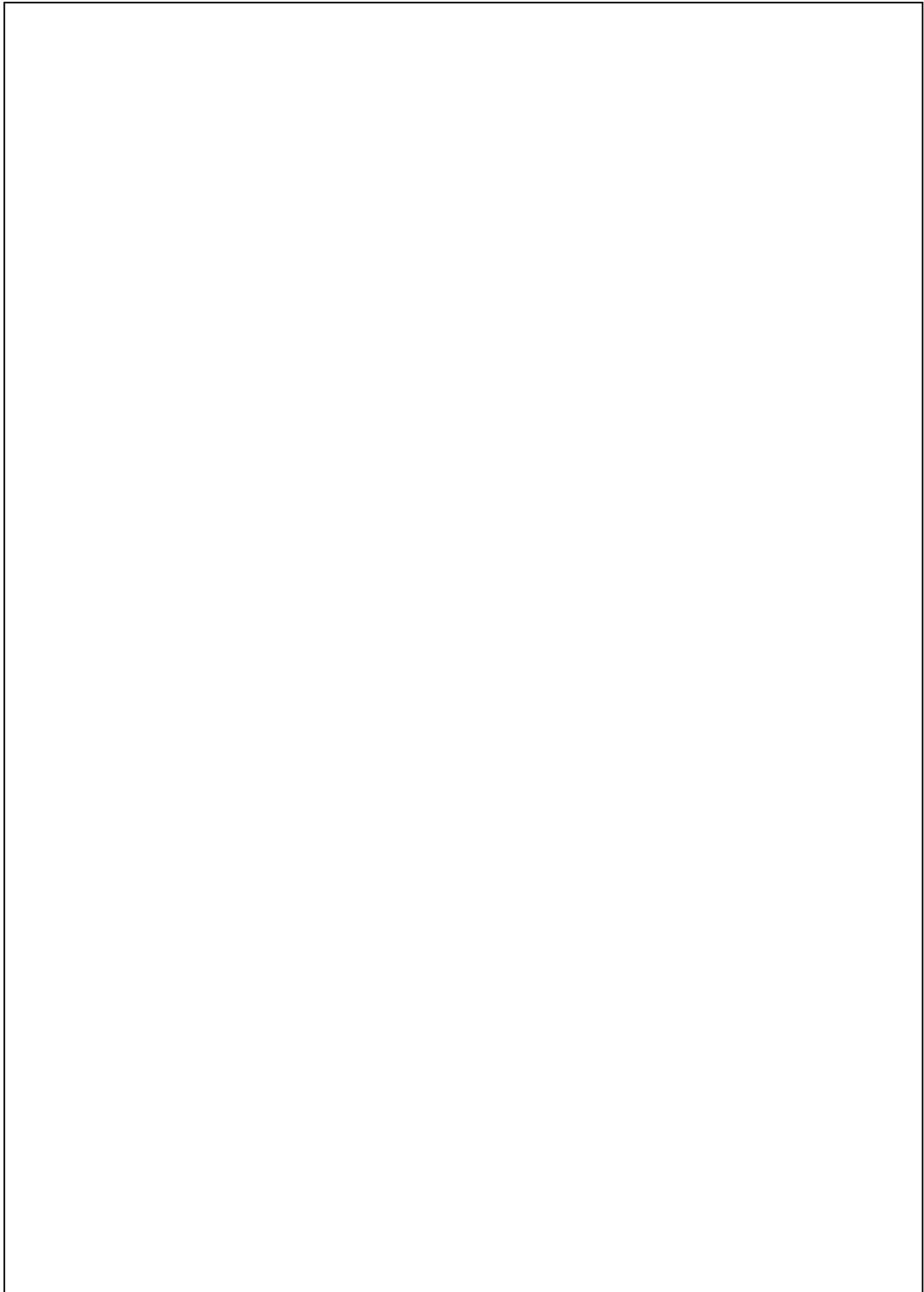

Physical Dimensions inches (millimeters) unless otherwise noted

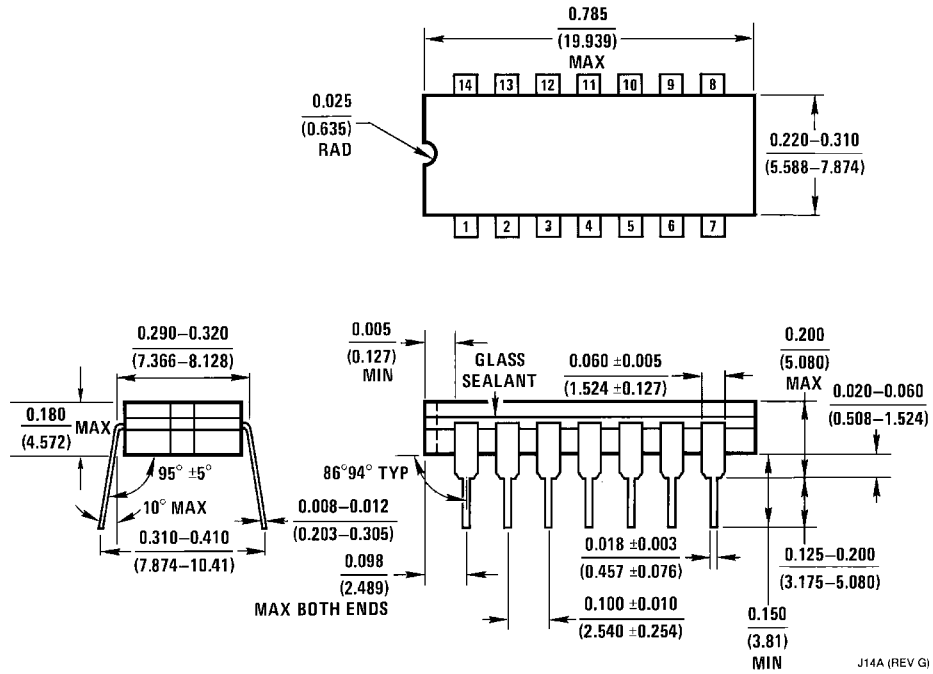

14-Lead Ceramic Dual-In-Line Package (J)
Order Number 5486DMQB or DM5486J
Package Number J14A

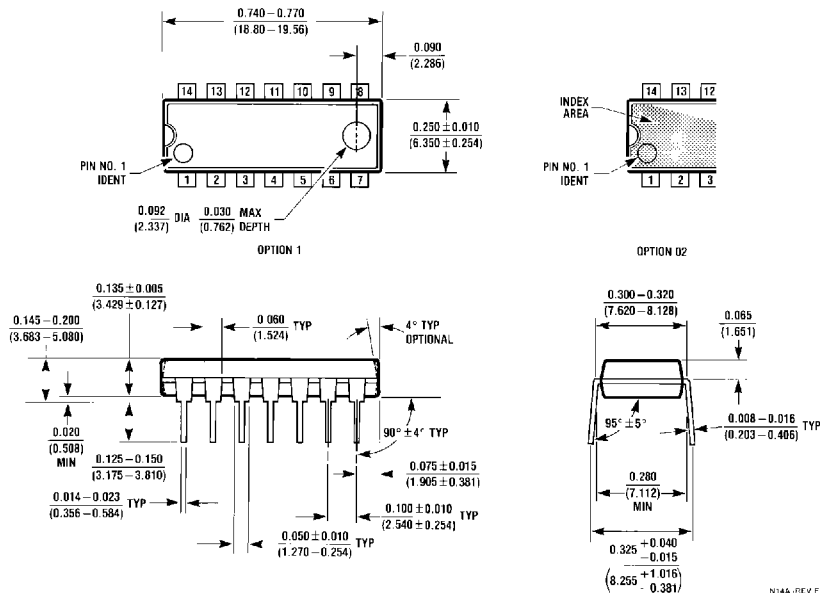

14-Lead Molded Dual-In-Line Package (N)
Order Number DM7486N
Package Number N14A

Physical Dimensions inches (millimeters) unless otherwise noted (Continued)

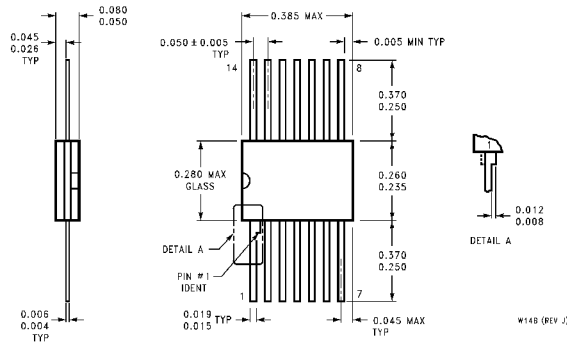

14-Lead Ceramic Flat Package (W)
Order Number 5486FMQB or DM5486W
Package Number W14B

LIFE SUPPORT POLICY

FAIRCHILD'S PRODUCTS ARE NOT AUTHORIZED FOR USE AS CRITICAL COMPONENTS IN LIFE SUPPORT DEVICES OR SYSTEMS WITHOUT THE EXPRESS WRITTEN APPROVAL OF THE PRESIDENT OF FAIRCHILD SEMICONDUCTOR CORPORATION. As used herein:

1. Life support devices or systems are devices or systems which, (a) are intended for surgical implant into the body, or (b) support or sustain life, and (c) whose failure to perform when properly used in accordance with instructions for use provided in the labeling, can be reasonably expected to result in a significant injury to the user.
2. A critical component in any component of a life support device or system whose failure to perform can be reasonably expected to cause the failure of the life support device or system, or to affect its safety or effectiveness.

Fairchild Semiconductor Corporation Americas
 Customer Response Center
 Tel: 1-888-522-5372

Fairchild Semiconductor Europe
 Fax: +49 (0) 1 80-530 85 86
 Email: europe.support@nsc.com
 Deutsch Tel: +49 (0) 8 141-35-0
 English Tel: +44 (0) 1 793-85-68-56
 Italy Tel: +39 (0) 2 57 5631

Fairchild Semiconductor Hong Kong Ltd.
 13th Floor, Straight Block,
 Ocean Centre, 5 Canton Rd.
 Tsimshatsui, Kowloon
 Hong Kong
 Tel: +852 2737-7200
 Fax: +852 2314-0061

National Semiconductor Japan Ltd.
 Tel: 81-3-5620-6175
 Fax: 81-3-5620-6179

www.fairchildsemi.com