

LM3590

LM3590 Series White LED Driver



Literature Number: SNVS258A

Series White LED Driver

General Description

The LM3590 is a White LED constant current driver capable of supplying up to 3 White LEDs connected in series with 20mA. This device operates over a wide 6V-12.6V input voltage range. The output can accommodate LEDs with a combined forward voltage of up to 11.5V, from a 12V input supply. The LED drive current is programmed by using an external resistor on the I_{SET} pin.

LED brightness can be linearly varied up to the programmed LED current by applying a Pulse Width Modulated (PWM) signal to the EN pin of the device. The LED output current of the LM3590 is tightly controlled over temperature and voltage. LED Current matching is guaranteed due to the series configuration of the LEDs. The series topology also simplifies the connection between the White LEDs in the display module and the LM3590 since only one connection is required.

The LM3590 typically draws only 50µA when operating in the no-load condition and draws less than 0.1µA when the device is shut down.

The LM3590 is available in a small 5-pin SOT23 package.

Features

- Drives up to 3 stacked white LEDs
- 6.0V-12.6V input voltage range
- Up to 20mA LED output current
- Excellent LED current matching guaranteed by series configuration
- Single connection to the White LEDs in the display module
- Tightly controlled programmable current source
- Low shutdown current (0.1µA typ.)
- PWM brightness control
- Very small solution size
- SOT23-5 package: 3mm × 3mm × 1.0mm (L×W×H)

Applications

- White LED Display Backlights
- Keypad Backlights
- General purpose constant current driver for high forward-voltage LEDs

Typical Application Circuit

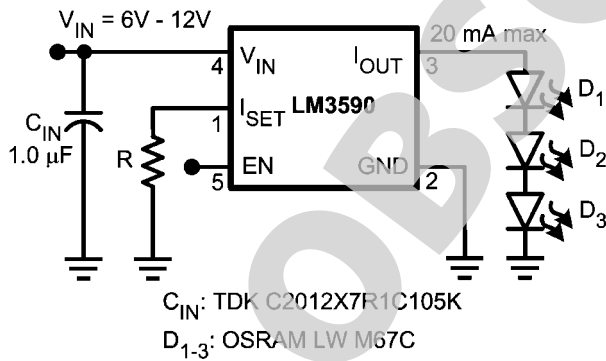

20081301

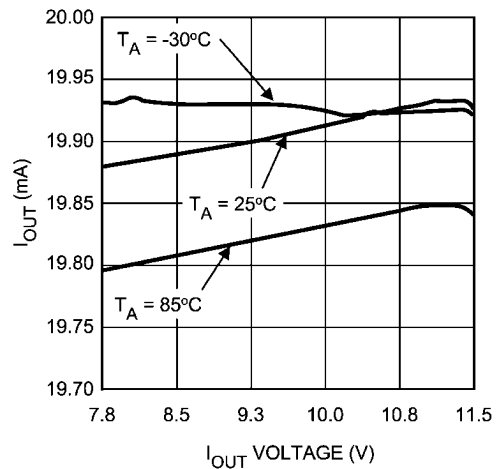

20081305

Connection Diagram

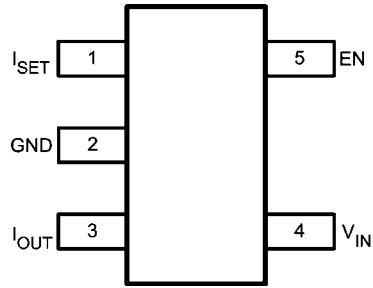

20081302

Ordering Information

Order Number	Package Description	Package Marking	Supplied As Tape and Reel
LM3590MF	SOT23-5	SABB*çZç1çX	250 Units, Tape and Reel
LM3590MFX	SOT23-5	SABB*çZç1çX	3000 Units, Tape and Reel

Pin Descriptions

Pin #	Name	Function
1	I _{SET}	Programmable LED current Input. The LED current has the following relationship with the resistor used: $R_{SET} = 100 \times (125 \div I_{OUT})$
2	GND	Ground Connection
3	I _{OUT}	Constant Current LED Output
4	V _{IN}	Power Supply Voltage Input. Input voltage range: 6V-12.6V
5	EN	Device Enable

Absolute Maximum Ratings (Note 1, Note 2)

2)

If Military/Aerospace specified devices are required, please contact the National Semiconductor Sales Office/Distributors for availability and specifications.

V_{IN}	-0.3 to 13.0V Max
EN	-0.3 to ($V_{IN}+0.3V$) w/ 13.0V max

Maximum Junction Temperature (T_{JMAX})	150°C
Storage Temperature	-65°C to +150°C
Maximum Lead Temperature (Soldering, 5 sec.)	260°C
ESD Rating <small>(Note 3)</small>	

Electrical Characteristics (Note 2, Note 6)

Limits in standard typeface are for $T_J = 25^\circ\text{C}$ and limits in **boldface** type apply over the full Operating Junction Temperature Range ($-40^\circ\text{C} \leq T_J \leq +110^\circ\text{C}$). Unless otherwise specified, $C_{IN} = 1 \mu\text{F}$, $V_{IN} = 12.0\text{V}$, $V_{EN} = 3.0\text{V}$, $R_{SET} = 6.19\text{k}\Omega$, $V_{IOUT} = 10.8\text{V}$.

Symbol	Parameter	Conditions	Min	Typ	Max	Units
I_{OUT}	Output Current Capability	$V_{IN} = 12\text{V}$ $7.5\text{V} \leq V_{IOUT} \leq 11.5\text{V}$	19 (-5%)	20	21 (+5%)	mA
		$V_{IOUT} = 10.8\text{V}$ $11.3\text{V} \leq V_{IN} \leq 12.6\text{V}$	19 (-5%)	20	21 (+5%)	
		$R_{SET} = 8.35\text{k}\Omega$		15		
		$R_{SET} = 12.5\text{k}\Omega$		10		
	Output Current Programming			$125 \div R_{SET}$		A
	I_{OUT} ratio to I_{SET}			100:1		
I_Q	Quiescent Supply Current	$11.3\text{V} \leq V_{IN} \leq 12.6\text{V}$ $R_{SET} = \text{OPEN}$ $I_{OUT} = \text{OPEN}$		50	75	μA
I_{SD}	Shutdown Supply Current	$V_{IN} = 12.6\text{V}$ $V_{EN} = 0\text{V}$		0.1	1	μA
V_{ISET}	I_{SET} Reference Voltage			1.25		V
V_{HR}	Minimum Current Source Voltage Headroom ($V_{IN} - V_{IOUT}$) <small>(Note 7)</small>	$I_{OUT} = 95\%$ nominal		300		mV
V_{IH}	Logic Input EN: High level		1.1		V_{IN}	V
V_{IL}	Logic Input EN: Low level		0		0.3	V
I_{EN}	Enable Pin Input Current <small>(Note 8)</small>			6		μA
t_{ON}	Turn-On Time	$I_{OUT} = 90\%$ of steady state		50		μs

Note 1: Absolute Maximum Ratings indicate limits beyond which damage to the device may occur. Operating Ratings are conditions under which operation of the device is guaranteed. Operating Ratings do not imply guaranteed performance limits. For guaranteed performance limits and associated test conditions, see the Electrical Characteristics table.

Note 2: All voltages are with respect to the potential at the GND pin.

Note 3: The human-body model is a 100pF capacitor discharged through a 1.5k Ω resistor into each pin. The machine model is a 220pF capacitor discharged directly into each pin.

Note 4: Maximum ambient temperature (T_{A-MAX}) is dependent on the maximum operating junction temperature ($T_{J-MAX-OP} = 110^\circ\text{C}$), the maximum power dissipation of the device in the application (P_{D-MAX}), and the junction-to-ambient thermal resistance of the part/package in the application (θ_{JA}), as given by the following equation: $T_{A-MAX} = T_{J-MAX-OP} - (\theta_{JA} \times P_{D-MAX})$. The ambient temperature operating rating is provided merely for convenience. This part may be operated outside the listed T_A rating, so long as the junction temperature of the device does not exceed the maximum operating rating of 110°C.

Note 5: Junction-to-ambient thermal resistance is highly application and board-layout dependent. In applications where high maximum power dissipation exists, special care must be paid to thermal dissipation issues. For more information on these topics, please refer to the **Power Dissipation** section of this datasheet.

Human Body Model	1.5kV
Machine Model	200V

Operating Conditions

Input Voltage Range	6.0V to 12.6V
EN Voltage Range	0V to V_{IN}
Ambient Temperature (T_A) Range	-40°C to +85°C
<small>(Note 4)</small>	
Junction Temperature (T_J) Range	-40°C to +110°C

Thermal Information

Junction-to-Ambient Thermal Resistance, SOT23-5 Package (θ_{JA}) <small>(Note 5)</small>	220°C/W
---	---------

Note 6: All room temperature limits are 100% tested or guaranteed through statistical analysis. All limits at temperature extremes are guaranteed by correlation using standard Statistical Quality Control methods (SQC). All limits are used to calculate Average Outgoing Quality Level (AOQL). Typical numbers are not guaranteed, but do represent the most likely norm.

Note 7: The current source is connected internally between V_{IN} and V_{IOUT} . The voltage across the current source, $[V_{IN} - V_{IOUT}]$, is referred to as headroom voltage. For the current source to regulate properly, a minimum headroom voltage must be present across it. Minimum required headroom voltage is proportional to the current flowing through the current source, as dictated by this equation: $V_{HR-MIN} = 300mV \times (I_{OUT} \div 20mA)$.

Note 8: An internal 500k Ω pull-down resistor is connected between the EN and GND pins.

Functional Block Diagram

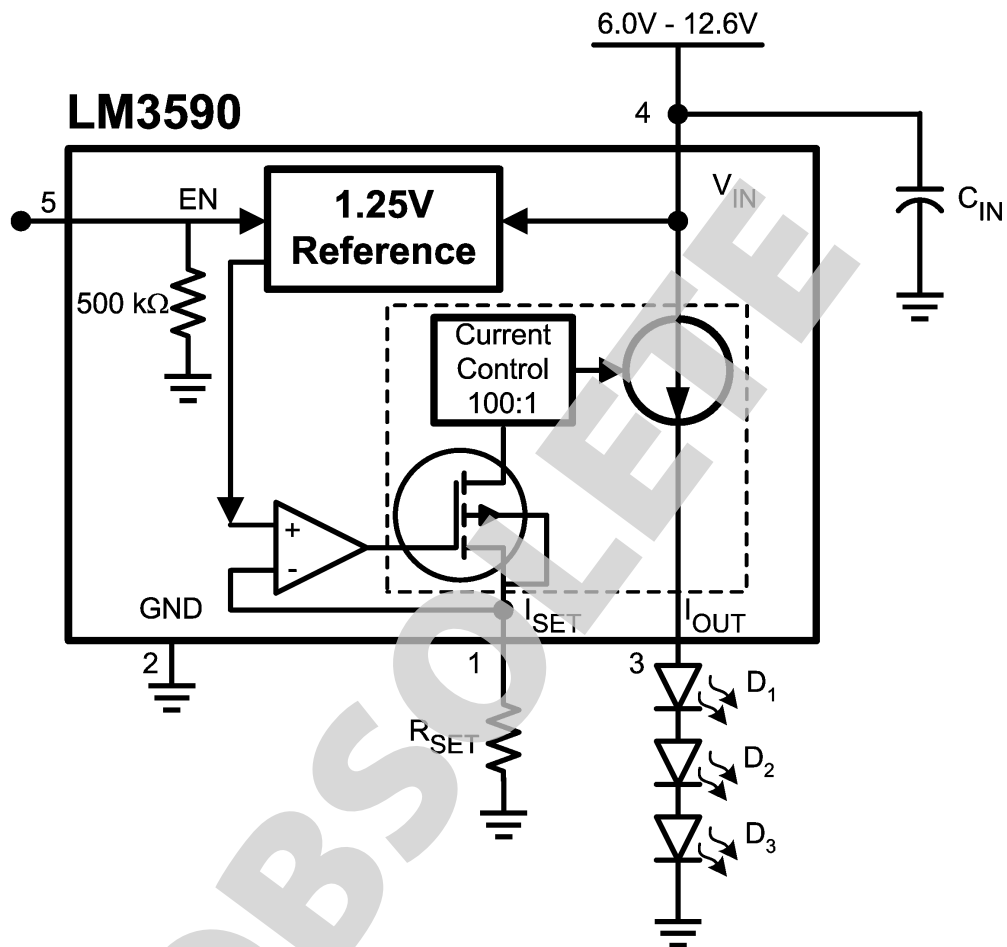

20081314

Typical Performance Characteristics Unless otherwise specified, $C_{IN} = 1\mu F$, $V_{IN} = 12.0V$, $V_{EN} = 3.0V$, $V_{IOUT} = 10.8V$, $R_{SET} = 6.19k\Omega$, $T_A = 25^\circ C$. C_{IN} is a low ESR multi-layer ceramic capacitor (MLCC).

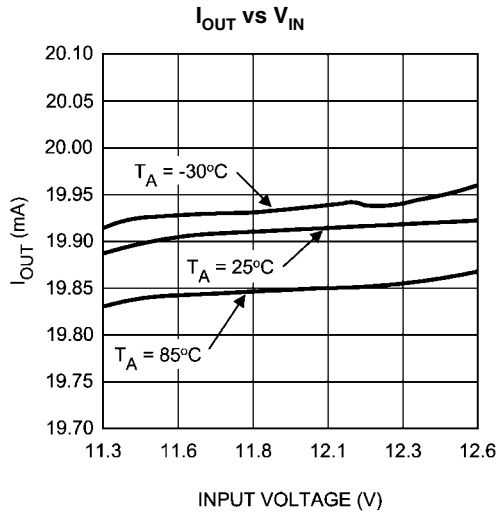

20081304

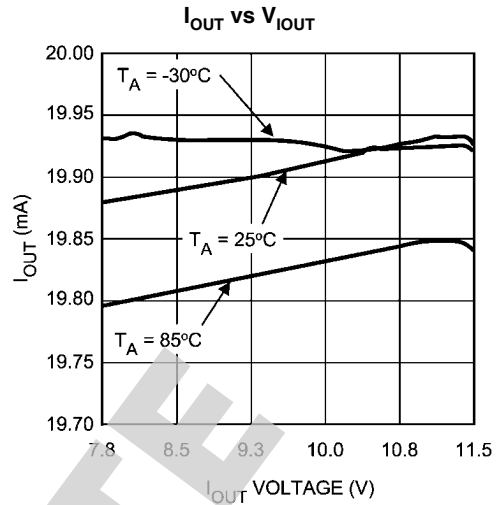

20081305

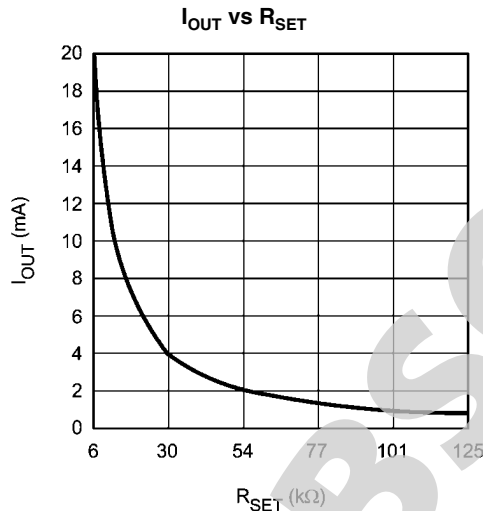

20081306

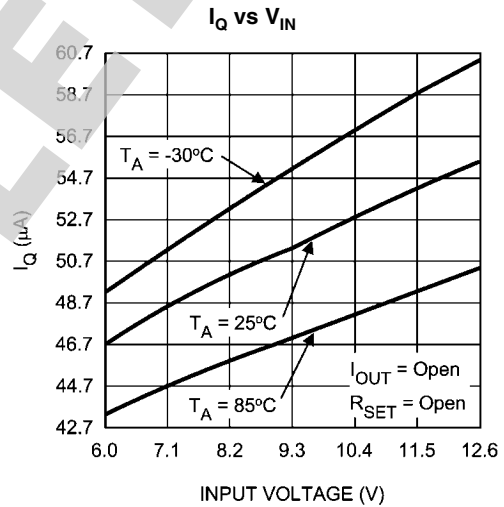

20081307

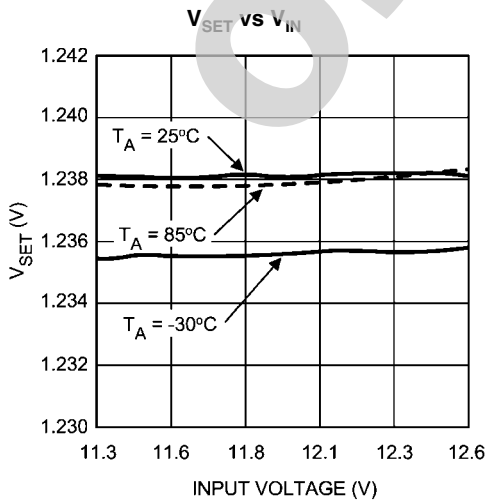

20081308

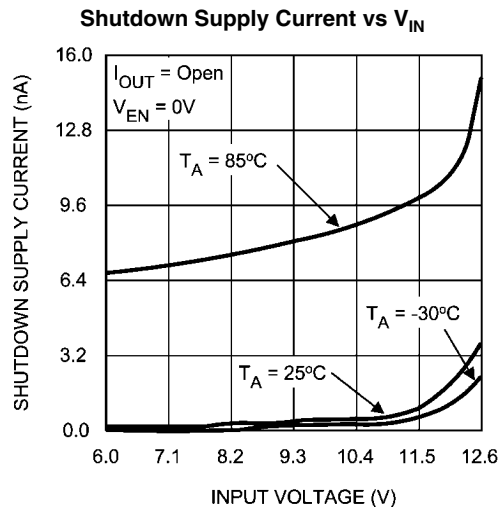

20081309

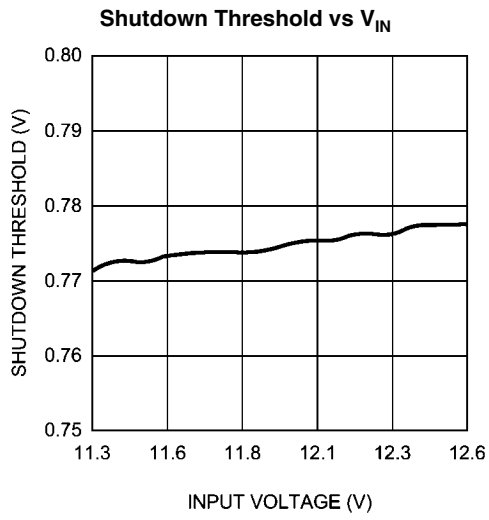

20081310

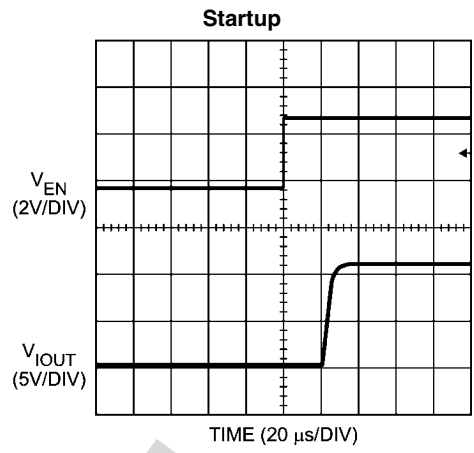

20081311

OBSOLETE

Application Information

CIRCUIT DESCRIPTION

The LM3590 is a constant current series White-LED Driver, providing up to 20mA from an input voltage between 7.5V to 12.6V. To set the LED drive current, the LM3590 uses a resistor connected to the I_{SET} pin to set a reference current. This reference current is then multiplied and mirrored to the constant current output, I_{OUT} . The LED brightness can be controlled by applying a PWM (Pulse Width Modulation) signal to the Enable pin (EN). (see **PWM BRIGHTNESS CONTROL PROCEDURES** section).

ENABLE MODE

The Enable pin (EN) disables the part and reduces the quiescent current to 0.1µA (typ.). The LM3590 has an active-high enable pin (LOW = shut down, HIGH = operating). The LM3590 EN pin can be driven with a low-voltage CMOS logic signal (1.5V logic, 1.8V logic, etc). There is an internal 500kΩ pull-down between the EN and GND pins of the LM3590.

CAPACITOR SELECTION

Although not required for normal operation, a capacitor can be added to the voltage input of the LM3590 to reduce line noise. A surface-mount multi-layer ceramic capacitor (MLCC) is recommended. MLCCs are small, inexpensive and have very low equivalent series resistance (ESR, $\leq 15\text{m}\Omega$ typ.). MLCCs with a X5R or X7R temperature characteristic are preferred for use with the LM3590. *Table 1* lists suggested capacitor suppliers for the typical application circuit.

TABLE 1. Ceramic Capacitor Manufacturers

Manufacturer	Contact
TDK	www.component.tdk.com
Murata	www.murata.com
Taiyo Yuden	www.t-yuden.com

LED SELECTION

The LM3590 is designed to drive up to 3 LEDs with the combined forward voltages of the LEDs being no greater than 11.5V, when using a 12V input supply. The typical and maximum diode forward voltage depends highly on the manufacturer and their technology. *Table 2* lists two suggested manufacturers. LED Forward current matching is guaranteed by design, due to the series LED configuration of the LM3590.

TABLE 2. White LED Selection

Manufacturer	Contact
Osram	www.osram-os.com
Nichia	www.nichia.com

LED HEADROOM VOLTAGE (V_{HR})

A single current source is connected internally between V_{IN} and I_{OUT} . The voltage across the current source, ($V_{IN} - V_{IOUT}$), is referred to as headroom voltage (V_{HR}). The current source requires a sufficient amount of headroom voltage to be present across it in order to regulate properly. Minimum required headroom voltage is proportional to the current flowing through the current source, as dictated by the equation:

$$V_{HR-MIN} = k_{HR} \times I_{OUT}$$

The parameter k_{HR} , typically 15mV/mA in the LM3590, is a proportionality constant that represents the ON-resistance of the internal current mirror transistors. For worst-case design calculations, using a k_{HR} of 20mV/mA is recommended.

(Worst-case recommendation accounts for parameter shifts from part-to-part variation and applies over the full operating temperature range). *Figure 1* shows how output current of the LM3590 varies with respect to headroom voltage.

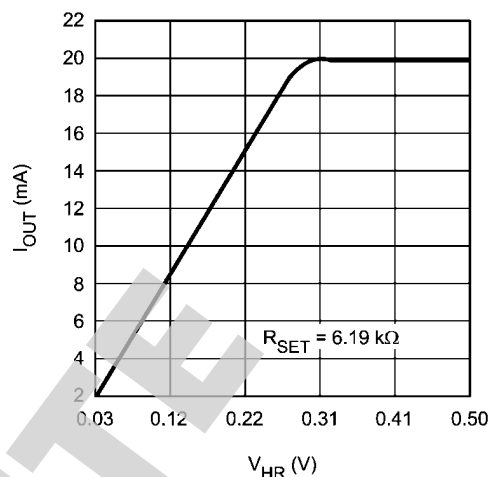

20081312

FIGURE 1. I_{OUT} vs V_{HR}
 $V_{HR} = V_{IN} - V_{IOUT}$
 $V_{IN} = 12.0V$

On the flat part of the graph, the current is regulated properly as there is sufficient headroom voltage for regulation. On the sloping part of the graph the headroom voltage is too small, the current source is squeezed, and the current drive capability is limited. Thus, operating the LM3590 with insufficient headroom voltage across the current source should be avoided.

I_{SET} PIN

An external resistor, R_{SET} , connected to the I_{SET} pin sets the output current. The internal current mirror sets the series LED output current with a 100:1 ratio to the current through R_{SET} . The current matching through each LED is guaranteed by the series LED drive topology. The following equation approximates the LED current:

$$I_{OUT} = 100 \times (1.25V \div R_{SET}) \text{ (Amps)}$$

PWM BRIGHTNESS CONTROL PROCEDURES

The brightness of the LEDs can be linearly varied from zero up to the maximum programmed current level by applying a Pulse-Width-Modulated signal to the EN pin of the LM3590. The following procedures illustrate how to program the LED drive current and adjust the output current level using a PWM signal.

- Determine the maximum desired I_{OUT} current. Use the I_{OUT} equation to calculate R_{SET}
- Brightness control can be implemented by pulsing a signal at the EN pin. LED brightness is proportional to the duty cycle (D) of the PWM signal. For linear brightness control over the full duty cycle adjustment range, the PWM frequency (f) should be limited to accommodate the turn-on time ($T_{ON} = 50\mu\text{s}$) of the device.

$$D \times (1/f) > T_{ON}$$

$$f_{MAX} = D_{MIN} \div T_{ON}$$

If the PWM frequency is much less than 100Hz, flicker may be seen in the LEDs. For the LM3590, zero duty cycle will turn off the LEDs and a 50% duty cycle will result in an average I_{OUT} being half of the programmed LED current. For example, if R_{SET} is set to program 15mA, a 50% duty cycle will result in an average I_{LED} of 7.5mA.

POWER DISSIPATION

The power dissipation ($P_{DISSIPATION}$) and junction temperature (T_J) can be approximated with the equations below. P_{IN} is the product of the input current and input voltage, P_{IOUT} is the power consumed by the LEDs, T_A is the ambient temperature, and θ_{JA} is the junction-to-ambient thermal resistance for the SOT23-5 package. V_{IN} is the input voltage to the LM3590,

V_{IOUT} is the sum of the forward voltages of LEDs connected to the I_{OUT} pin, and I_{OUT} is the programmed LED current.

$$\begin{aligned} P_{DISSIPATION} &= P_{IN} - P_{IOUT} \\ &= (V_{IN} \times I_{OUT}) - (V_{IOUT} \times I_{OUT}) \\ T_J &= T_A + (P_{DISSIPATION} \times \theta_{JA}) \end{aligned}$$

The junction temperature rating takes precedence over the ambient temperature rating. The LM3590 may be operated outside the ambient temperature rating, so long as the junction temperature of the device does not exceed the maximum operating rating of 110°C. The maximum ambient temperature rating must be derated in applications where high power dissipation and/or poor thermal resistance causes the junction temperature to exceed 110°C.

Application Circuits

Figure 2 shows how to program the LED current to four different DC levels using two digital logic signals. The programmed LED current is a function of the equivalent

resistance on the I_{SET} pin (R_{ISET}), resulting from the logic signals on SET1 and SET2. Example values for R_1 , R_2 , and R_{SET} at the resulting 4 current levels are shown below.

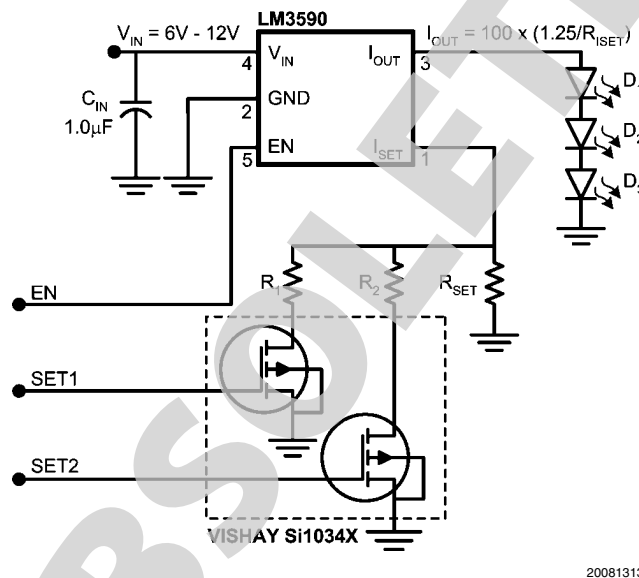

20081313

FIGURE 2. Example: $R_1 = 15.8k\Omega$, $R_2 = 31.6k\Omega$, $R_{SET} = 31.6k\Omega$

TABLE 3. Digital LED Current Programming

EN	SET1	SET2	R_{ISET}	Example R_{ISET}	Example I_{OUT}
0	X	X	Shutdown	Shutdown	Shutdown
1	1	1	$R_{SET} \parallel R_1 \parallel R_2$	$31.6k\Omega \parallel 15.k\Omega \parallel 31.6k\Omega$	16mA
1	1	0	$R_{SET} \parallel R_1$	$31.6k\Omega \parallel 15.k\Omega$	12mA
1	0	1	$R_{SET} \parallel R_2$	$31.6k\Omega \parallel 31.6k\Omega$	8mA
1	0	0	R_{SET}	31.6k Ω	4mA

Physical Dimensions inches (millimeters) unless otherwise noted

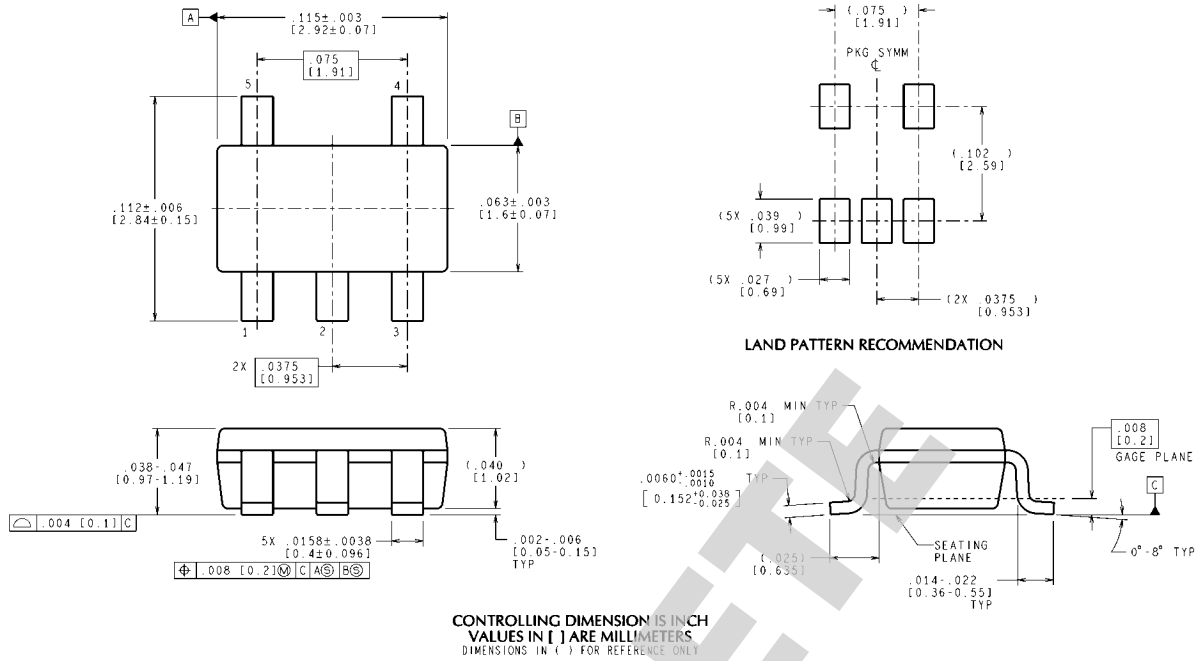

5 Lead Small Outline Package (SOT23-5)
NS Package Number MF05A

MF05A (Rev D)

OBSOLETE

Notes

For more National Semiconductor product information and proven design tools, visit the following Web sites at:
www.national.com

Products		Design Support	
Amplifiers	www.national.com/amplifiers	WEBENCH® Tools	www.national.com/webench
Audio	www.national.com/audio	App Notes	www.national.com/appnotes
Clock and Timing	www.national.com/timing	Reference Designs	www.national.com/refdesigns
Data Converters	www.national.com/adc	Samples	www.national.com/samples
Interface	www.national.com/interface	Eval Boards	www.national.com/evalboards
LVDS	www.national.com/lvds	Packaging	www.national.com/packaging
Power Management	www.national.com/power	Green Compliance	www.national.com/quality/green
Switching Regulators	www.national.com/switchers	Distributors	www.national.com/contacts
LDOs	www.national.com/ldo	Quality and Reliability	www.national.com/quality
LED Lighting	www.national.com/led	Feedback/Support	www.national.com/feedback
Voltage References	www.national.com/vref	Design Made Easy	www.national.com/easy
PowerWise® Solutions	www.national.com/powerwise	Applications & Markets	www.national.com/solutions
Serial Digital Interface (SDI)	www.national.com/sdi	Mil/Aero	www.national.com/milaero
Temperature Sensors	www.national.com/tempensors	SolarMagic™	www.national.com/solarmagic
PLL/VCO	www.national.com/wireless	PowerWise® Design University	www.national.com/training

THE CONTENTS OF THIS DOCUMENT ARE PROVIDED IN CONNECTION WITH NATIONAL SEMICONDUCTOR CORPORATION ("NATIONAL") PRODUCTS. NATIONAL MAKES NO REPRESENTATIONS OR WARRANTIES WITH RESPECT TO THE ACCURACY OR COMPLETENESS OF THE CONTENTS OF THIS PUBLICATION AND RESERVES THE RIGHT TO MAKE CHANGES TO SPECIFICATIONS AND PRODUCT DESCRIPTIONS AT ANY TIME WITHOUT NOTICE. NO LICENSE, WHETHER EXPRESS, IMPLIED, ARISING BY ESTOPPEL OR OTHERWISE, TO ANY INTELLECTUAL PROPERTY RIGHTS IS GRANTED BY THIS DOCUMENT.

TESTING AND OTHER QUALITY CONTROLS ARE USED TO THE EXTENT NATIONAL DEEMS NECESSARY TO SUPPORT NATIONAL'S PRODUCT WARRANTY. EXCEPT WHERE MANDATED BY GOVERNMENT REQUIREMENTS, TESTING OF ALL PARAMETERS OF EACH PRODUCT IS NOT NECESSARILY PERFORMED. NATIONAL ASSUMES NO LIABILITY FOR APPLICATIONS ASSISTANCE OR BUYER PRODUCT DESIGN. BUYERS ARE RESPONSIBLE FOR THEIR PRODUCTS AND APPLICATIONS USING NATIONAL COMPONENTS. PRIOR TO USING OR DISTRIBUTING ANY PRODUCTS THAT INCLUDE NATIONAL COMPONENTS, BUYERS SHOULD PROVIDE ADEQUATE DESIGN, TESTING AND OPERATING SAFEGUARDS.

EXCEPT AS PROVIDED IN NATIONAL'S TERMS AND CONDITIONS OF SALE FOR SUCH PRODUCTS, NATIONAL ASSUMES NO LIABILITY WHATSOEVER, AND NATIONAL DISCLAIMS ANY EXPRESS OR IMPLIED WARRANTY RELATING TO THE SALE AND/OR USE OF NATIONAL PRODUCTS INCLUDING LIABILITY OR WARRANTIES RELATING TO FITNESS FOR A PARTICULAR PURPOSE, MERCHANTABILITY, OR INFRINGEMENT OF ANY PATENT, COPYRIGHT OR OTHER INTELLECTUAL PROPERTY RIGHT.

LIFE SUPPORT POLICY

NATIONAL'S PRODUCTS ARE NOT AUTHORIZED FOR USE AS CRITICAL COMPONENTS IN LIFE SUPPORT DEVICES OR SYSTEMS WITHOUT THE EXPRESS PRIOR WRITTEN APPROVAL OF THE CHIEF EXECUTIVE OFFICER AND GENERAL COUNSEL OF NATIONAL SEMICONDUCTOR CORPORATION. As used herein:

Life support devices or systems are devices which (a) are intended for surgical implant into the body, or (b) support or sustain life and whose failure to perform when properly used in accordance with instructions for use provided in the labeling can be reasonably expected to result in a significant injury to the user. A critical component is any component in a life support device or system whose failure to perform can be reasonably expected to cause the failure of the life support device or system or to affect its safety or effectiveness.

National Semiconductor and the National Semiconductor logo are registered trademarks of National Semiconductor Corporation. All other brand or product names may be trademarks or registered trademarks of their respective holders.

Copyright© 2011 National Semiconductor Corporation

For the most current product information visit us at www.national.com



www.national.com

**National Semiconductor
Americas Technical
Support Center**
Email: support@nsc.com
Tel: 1-800-272-9959

**National Semiconductor Europe
Technical Support Center**
Email: europe.support@nsc.com

**National Semiconductor Asia
Pacific Technical Support Center**
Email: ap.support@nsc.com

**National Semiconductor Japan
Technical Support Center**
Email: jpn.feedback@nsc.com

IMPORTANT NOTICE

Texas Instruments Incorporated and its subsidiaries (TI) reserve the right to make corrections, modifications, enhancements, improvements, and other changes to its products and services at any time and to discontinue any product or service without notice. Customers should obtain the latest relevant information before placing orders and should verify that such information is current and complete. All products are sold subject to TI's terms and conditions of sale supplied at the time of order acknowledgment.

TI warrants performance of its hardware products to the specifications applicable at the time of sale in accordance with TI's standard warranty. Testing and other quality control techniques are used to the extent TI deems necessary to support this warranty. Except where mandated by government requirements, testing of all parameters of each product is not necessarily performed.

TI assumes no liability for applications assistance or customer product design. Customers are responsible for their products and applications using TI components. To minimize the risks associated with customer products and applications, customers should provide adequate design and operating safeguards.

TI does not warrant or represent that any license, either express or implied, is granted under any TI patent right, copyright, mask work right, or other TI intellectual property right relating to any combination, machine, or process in which TI products or services are used. Information published by TI regarding third-party products or services does not constitute a license from TI to use such products or services or a warranty or endorsement thereof. Use of such information may require a license from a third party under the patents or other intellectual property of the third party, or a license from TI under the patents or other intellectual property of TI.

Reproduction of TI information in TI data books or data sheets is permissible only if reproduction is without alteration and is accompanied by all associated warranties, conditions, limitations, and notices. Reproduction of this information with alteration is an unfair and deceptive business practice. TI is not responsible or liable for such altered documentation. Information of third parties may be subject to additional restrictions.

Resale of TI products or services with statements different from or beyond the parameters stated by TI for that product or service voids all express and any implied warranties for the associated TI product or service and is an unfair and deceptive business practice. TI is not responsible or liable for any such statements.

TI products are not authorized for use in safety-critical applications (such as life support) where a failure of the TI product would reasonably be expected to cause severe personal injury or death, unless officers of the parties have executed an agreement specifically governing such use. Buyers represent that they have all necessary expertise in the safety and regulatory ramifications of their applications, and acknowledge and agree that they are solely responsible for all legal, regulatory and safety-related requirements concerning their products and any use of TI products in such safety-critical applications, notwithstanding any applications-related information or support that may be provided by TI. Further, Buyers must fully indemnify TI and its representatives against any damages arising out of the use of TI products in such safety-critical applications.

TI products are neither designed nor intended for use in military/aerospace applications or environments unless the TI products are specifically designated by TI as military-grade or "enhanced plastic." Only products designated by TI as military-grade meet military specifications. Buyers acknowledge and agree that any such use of TI products which TI has not designated as military-grade is solely at the Buyer's risk, and that they are solely responsible for compliance with all legal and regulatory requirements in connection with such use.

TI products are neither designed nor intended for use in automotive applications or environments unless the specific TI products are designated by TI as compliant with ISO/TS 16949 requirements. Buyers acknowledge and agree that, if they use any non-designated products in automotive applications, TI will not be responsible for any failure to meet such requirements.

Following are URLs where you can obtain information on other Texas Instruments products and application solutions:

Products

Audio	www.ti.com/audio
Amplifiers	amplifier.ti.com
Data Converters	dataconverter.ti.com
DLP® Products	www.dlp.com
DSP	dsp.ti.com
Clocks and Timers	www.ti.com/clocks
Interface	interface.ti.com
Logic	logic.ti.com
Power Mgmt	power.ti.com
Microcontrollers	microcontroller.ti.com
RFID	www.ti-rfid.com
OMAP Mobile Processors	www.ti.com/omap
Wireless Connectivity	www.ti.com/wirelessconnectivity

Applications

Communications and Telecom	www.ti.com/communications
Computers and Peripherals	www.ti.com/computers
Consumer Electronics	www.ti.com/consumer-apps
Energy and Lighting	www.ti.com/energy
Industrial	www.ti.com/industrial
Medical	www.ti.com/medical
Security	www.ti.com/security
Space, Avionics and Defense	www.ti.com/space-avionics-defense
Transportation and Automotive	www.ti.com/automotive
Video and Imaging	www.ti.com/video

TI E2E Community Home Page

e2e.ti.com

Mailing Address: Texas Instruments, Post Office Box 655303, Dallas, Texas 75265
Copyright © 2011, Texas Instruments Incorporated