

# SN54BCT29825, SN74BCT29825 8-BIT BUS-INTERFACE FLIP-FLOPS WITH 3-STATE OUTPUTS

SCBS075A – SEPTEMBER 1991 – REVISED NOVEMBER 1993

- **State-of-the-Art BICMOS Design Significantly Reduces I<sub>CCZ</sub>**
- **ESD Protection Exceeds 2000 V Per MIL-STD-883C, Method 3015; Exceeds 200 V Using Machine Model (C = 200 pF, R = 0)**
- **3-State Buffer-Type Outputs Drive Bus Lines Directly**
- **Package Options Include Plastic Small-Outline Packages (DW), Ceramic Chip Carriers (FK) and Flatpacks (W), and Standard Plastic and Ceramic 300-mil DIPs (JT, NT)**

## description

These 8-bit bus-interface flip-flops feature 3-state outputs designed specifically for driving highly capacitive or relatively low-impedance loads. They are particularly suitable for implementing wider buffer registers, I/O ports, bidirectional bus drivers with parity, and working registers.

The eight flip-flops are edge-triggered D-type flip-flops. With the clock-enable (CLKEN) input low, the device enters data on the low-to-high transition of the clock. Taking  $\overline{\text{CLKEN}}$  high disables the clock buffer, thus latching the outputs. Taking the clear ( $\overline{\text{CLR}}$ ) input low causes the eight Q outputs to go low independently of the clock.

Buffered output-enable ( $\overline{\text{OE1}}$ ,  $\overline{\text{OE2}}$ , or  $\overline{\text{OE3}}$ ) inputs can be used to place the eight outputs in either a normal logic state (high or low) or a high-impedance state. In the high-impedance state, the outputs neither load nor drive the bus lines significantly. The high-impedance state and increased drive provide the capability to drive bus lines without need for interface or pullup components.

The output-enable inputs do not affect the internal operation of the flip-flops. Old data can be retained or new data can be entered while the outputs are in the high-impedance state.

The SN54BCT29825 is characterized for operation over the full military temperature range of  $-55^{\circ}\text{C}$  to  $125^{\circ}\text{C}$ . The SN74BCT29825 is characterized for operation from  $0^{\circ}\text{C}$  to  $70^{\circ}\text{C}$ .

SN54BCT29825 . . . JT OR W PACKAGE  
SN74BCT29825 . . . DW OR NT PACKAGE  
(TOP VIEW)

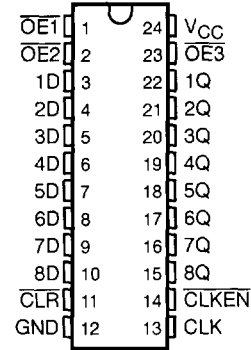

SN54BCT29825 . . . FK PACKAGE  
(TOP VIEW)

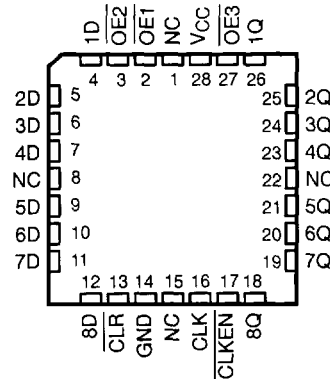

NC – No internal connection

PRODUCTION DATA information is current as of publication date. Products conform to specifications per the terms of Texas Instruments standard warranty. Production processing does not necessarily include testing of all parameters.



POST OFFICE BOX 655303 • DALLAS, TEXAS 75265

Copyright © 1993, Texas Instruments Incorporated

**SN54BCT29825, SN74BCT29825**  
**8-BIT BUS-INTERFACE FLIP-FLOPS**  
**WITH 3-STATE OUTPUTS**

SCBS075A – SEPTEMBER 1991 – REVISED NOVEMBER 1993

**FUNCTION TABLE**

INPUTS					OUTPUT
$\overline{OE}\dagger$	CLR	CLKEN	CLK	D	Q
L	L	X	X	X	L
L	H	L	↑	H	H
L	H	L	↑	L	L
L	H	H	H or L	X	$Q_0$
H	X	X	X	X	Z

†  $\overline{OE}$  = H if any of the output-enable inputs is high.  
 $\overline{OE}$  = L if all of the output-enable inputs are low.

**logic symbol‡**

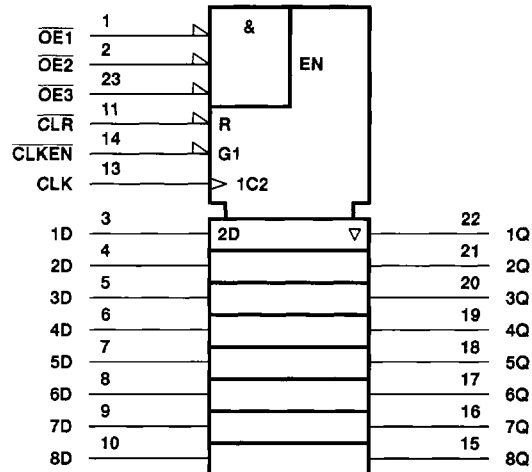

‡ This symbol is in accordance with ANSI/IEEE Std 91-1984 and IEC Publication 617-12.  
 Pin numbers shown are for the DW, JT, NT, and W packages.

**SN54BCT29825, SN74BCT29825**  
**8-BIT BUS-INTERFACE FLIP-FLOPS**  
**WITH 3-STATE OUTPUTS**

SCBS075A – SEPTEMBER 1991 – REVISED NOVEMBER 1993

**logic diagram (positive logic)**

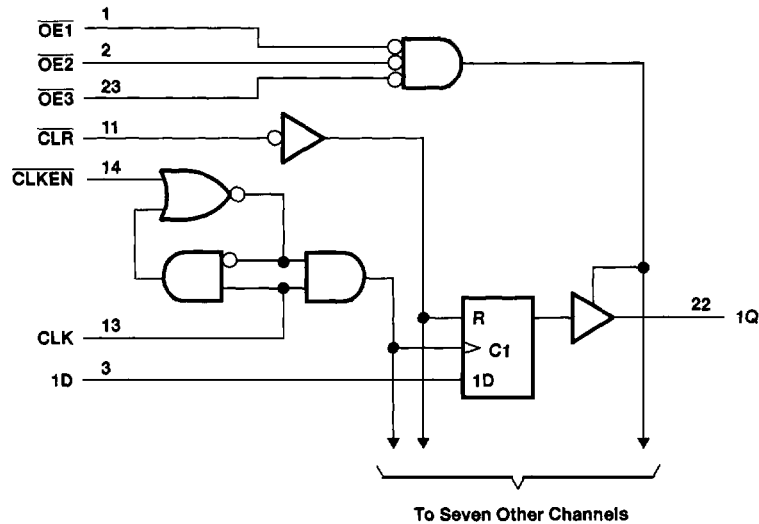

Pin numbers shown are for the DW, JT, NT, and W packages.

**absolute maximum ratings over operating free-air temperature range (unless otherwise noted)†**

Supply voltage range, $V_{CC}$ .....	-0.5 V to 7 V
Input voltage range, $V_I$ (see Note 1) .....	-0.5 V to 7 V
Voltage range applied to any output in the disabled or power-off state, $V_O$ .....	-0.5 V to 5.5 V
Voltage range applied to any output in the high state, $V_{OH}$ .....	-0.5 V to $V_{CC}$
Input clamp current, $I_{IK}$ ( $V_I < 0$ ) .....	-30 mA
Current into any output in the low state, $I_{OL}$ : SN54BCT29825 .....	48 mA
SN74BCT29825 .....	96 mA
Operating free-air temperature range: SN54BCT29825 .....	-55°C to 125°C
SN74BCT29825 .....	0°C to 70°C
Storage temperature range .....	-65°C to 150°C

† Stresses beyond those listed under "absolute maximum ratings" may cause permanent damage to the device. These are stress ratings only, and functional operation of the device at these or any other conditions beyond those indicated under "recommended operating conditions" is not implied. Exposure to absolute-maximum-rated conditions for extended periods may affect device reliability.

NOTE 1: The input and output negative-voltage ratings may be exceeded if the input and output clamp-current ratings are observed.

**recommended operating conditions**

	SN54BCT29825			SN74BCT29825			UNIT
	MIN	NOM	MAX	MIN	NOM	MAX	
$V_{CC}$ Supply voltage	4.5	5	5.5	4.5	5	5.5	V
$V_{IH}$ High-level input voltage	2			2			V
$V_{IL}$ Low-level input voltage			0.8			0.8	V
$I_{IK}$ Input clamp current			-18			-18	mA
$I_{OH}$ High-level output current			-15			-24	mA
$I_{OL}$ Low-level output current			24			48	mA
$T_A$ Operating free-air temperature	-55	125		0	70		°C



POST OFFICE BOX 655303 • DALLAS, TEXAS 75265

**SN54BCT29825, SN74BCT29825**  
**8-BIT BUS-INTERFACE FLIP-FLOPS**  
**WITH 3-STATE OUTPUTS**

SCBS075A – SEPTEMBER 1991 – REVISED NOVEMBER 1993

**electrical characteristics over recommended operating free-air temperature range (unless otherwise noted)**

PARAMETER	TEST CONDITIONS	SN54BCT29825		SN74BCT29825		UNIT		
		MIN	TYP†	MAX	MIN		TYP†	MAX
$V_{IK}$	$V_{CC} = 4.5\text{ V}$ , $I_I = -18\text{ mA}$			-1.2		V		
$V_{OH}$	$V_{CC} = 4.5\text{ V}$	$I_{OH} = -15\text{ mA}$		2	3.2	2.4	3.3	V
		$I_{OH} = -24\text{ mA}$				2	3.1	
$V_{OL}$	$V_{CC} = 4.75\text{ V}$	$I_{OH} = -3\text{ mA}$				2.7		V
		$V_{CC} = 4.5\text{ V}$	$I_{OL} = 24\text{ mA}$		0.38	0.55		
			$I_{OL} = 48\text{ mA}$				0.42	0.55
$I_I$	$V_{CC} = 5.5\text{ V}$ , $V_I = 7\text{ V}$			0.1		0.1	mA	
$I_{IH}$	$V_{CC} = 5.5\text{ V}$ , $V_I = 2.7\text{ V}$	-10		-75	-10	-75	$\mu\text{A}$	
$I_{IL}$	$V_{CC} = 5.5\text{ V}$ , $V_I = 0.5\text{ V}$			-0.2		-0.2	mA	
$I_{OS}^\ddagger$	$V_{CC} = 5.5\text{ V}$ , $V_O = 0$	-75		-250	-75	-250	mA	
$I_{OZH}$	$V_{CC} = 5.5\text{ V}$ , $V_O = 2.7\text{ V}$			20		20	$\mu\text{A}$	
$I_{OZL}$	$V_{CC} = 5.5\text{ V}$ , $V_O = 0.5\text{ V}$			-20		-20	$\mu\text{A}$	
$I_{CCL}$	$V_{CC} = 5.5\text{ V}$ , Outputs open	26	40	26	40	mA		
$I_{CCH}$	$V_{CC} = 5.5\text{ V}$ , Outputs open	10	16	10	16	mA		
$I_{CCZ}$	$V_{CC} = 5.5\text{ V}$ , Outputs open	6	10	6	10	mA		
$C_i$	$V_{CC} = 5\text{ V}$ , $V_I = 2.5\text{ V}$ or $0.5\text{ V}$			5		5	pF	
$C_o$	$V_{CC} = 5\text{ V}$ , $V_O = 2.5\text{ V}$ or $0.5\text{ V}$			7		7	pF	

† All typical values are at  $V_{CC} = 5\text{ V}$ ,  $T_A = 25^\circ\text{C}$ .

‡ Not more than one output should be tested at a time, and the duration of the test should not exceed one second.

**timing requirements over recommended ranges of supply voltage and operating free-air temperature (unless otherwise noted)**

		$V_{CC} = 5\text{ V}$ , $T_A = 25^\circ\text{C}$		SN54BCT29825		SN74BCT29825		UNIT
		MIN	MAX	MIN	MAX	MIN	MAX	
$f_{\text{clock}}$	Clock frequency	0	125	0	125	0	125	MHz
$t_w$	Pulse duration	$\overline{\text{CLR}}$ low		4		4		ns
		CLK high or low		4		4		
$t_{\text{su}}$	Setup time before $\text{CLK}\uparrow$	Data high		6		6		ns
		Data low		3.5		3.5		
		$\overline{\text{CLR}}$		1		1		
		CLKEN high or low		8		8		
$t_h$	Hold time after $\text{CLK}\uparrow$	Data high		1.5		1.5		ns
		Data low		0		0		
		CLKEN high or low		0.5		0.5		



**SN54BCT29825, SN74BCT29825**  
**8-BIT BUS-INTERFACE FLIP-FLOPS**  
**WITH 3-STATE OUTPUTS**

SCBS076A – SEPTEMBER 1991 – REVISED NOVEMBER 1993

switching characteristics over recommended ranges of supply voltage and operating free-air temperature,  $C_L = 50$  pF (unless otherwise noted) (see Note 2)

PARAMETER	FROM (INPUT)	TO (OUTPUT)	$V_{CC} = 5$ V, $T_A = 25^\circ\text{C}$	SN54BCT29825	SN74BCT29825	UNIT
$f_{max}$			125	125	125	MHz
$t_{PLH}$	CLK	Q	2.2 5.4 7.8	2.2 9.9	2.2 9	ns
$t_{PHL}$			3.1 5.9 7.7	3.1 9.1	3.1 8.4	
$t_{PHL}$	$\overline{CLR}$	Q	3 6.4 8.3	3 9.6	3 9.5	ns
$t_{PZH}$	$\overline{OE}$	Q	2.1 6.2 8.4	2.1 10.8	2.1 10.3	ns
$t_{PZL}$			5.1 9.1 11.4	5.1 13.6	5.1 13.2	
$t_{PHZ}$	$\overline{OE}$	Q	2.4 5.9 7.8	2.4 9.8	2.4 9	ns
$t_{PLZ}$			1.8 5.2 7.2	1.8 9.2	1.8 8.2	

NOTE 2: Load circuits and voltage waveforms are shown in Section 1.



POST OFFICE BOX 655303 • DALLAS, TEXAS 75265