

# XC74UL08AA



## CMOS Logic

- ◆ CMOS 2-Input AND Gate
- ◆ High Speed Operation :  $t_{pd} = 2.6\text{ns}$  (TYP.)
- ◆ Operating Voltage Range : 2V ~ 5.5V
- ◆ Low Power Consumption : 1  $\mu\text{A}$  (MAX.)

## APPLICATIONS

- Palmtops
- Digital equipment

## GENERAL DESCRIPTION

The XC74UL08AA is a 2-input CMOS AND Gate, manufactured using silicon gate CMOS fabrication.

CMOS low power circuit operation makes high speed LS-TTL operation achievable.

With a wave forming buffer connected internally, stabilized output can be achieved as the circuit offers high noise immunity.

As the XC74UL08AA is integrated into mini molded, SSOT-25 and SOT-25 packages, high density mounting is possible.

## FEATURES

**High Speed Operation** :  $t_{pd} = 2.6\text{ns}$  (TYP.)

**Operating Voltage Range** : 2V ~ 5.5V

**Low Power Consumption** : 1  $\mu\text{A}$  (MAX.)

**Ultra Small Packages** : SSOT-25 and SOT-25

## PIN CONFIGURATION

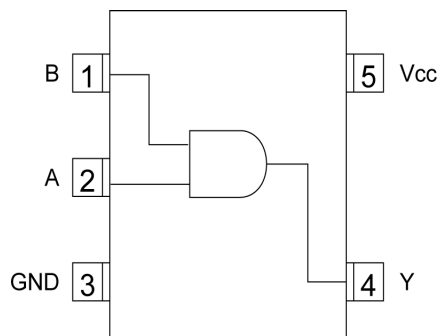

SSOT-25/SOT-25  
(TOP VIEW)

## FUNCTIONS

INPUT		OUTPUT
A	B	Y
L	L	L
L	H	L
H	L	L
H	H	H

H=High level

L=Low level

## ABSOLUTE MAXIMUM RATINGS

$T_a = -40^\circ\text{C} \sim 85^\circ\text{C}$

PARAMETER	SYMBOL	RATINGS	UNITS
Supply Voltage	V <sub>CC</sub>	-0.5~+6.0	V
Input Voltage	V <sub>IN</sub>	-0.5~+6.0	V
Output Voltage	V <sub>OUT</sub>	-0.5~V <sub>CC</sub> +0.5	V
Input Diode Current	I <sub>IK</sub>	-20	mA
Output Diode Current	I <sub>OK</sub>	±20	mA
Output Current	I <sub>OUT</sub>	±25	mA
V <sub>CC</sub> ,GND Current	I <sub>CC</sub> ,I <sub>GND</sub>	±50	mA
Power Dissipation( $T_a=55^\circ\text{C}$ )	P <sub>d</sub>	150	mW
Storage Temperature Range	T <sub>stg</sub>	-65~+150	°C

\* Voltage is all ground standardized.

# XC74UL08AA

## RECOMMENDED OPERATING CONDITIONS

PARAMETER	SYMBOL	V <sub>CC</sub> (V)	CONDITIONS	UNITS
Supply Voltage	V <sub>CC</sub>	—	2~5.5	V
Input Voltage	V <sub>IN</sub>	—	0~5.5	V
Output Voltage	V <sub>OUT</sub>	—	0~V <sub>CC</sub>	V
Operating Temperature Range	T <sub>opr</sub>	—	-40~+85	°C
Output Current	I <sub>OH</sub>	3.0	-4	mA
		4.5	-8	
	I <sub>OL</sub>	3.0	4	
		4.5	8	
Input Rise and Fall Time	t <sub>r,tf</sub>	3.3	0~100	ns
		5.0	0~20	

## DC ELECTRICAL CHARACTERISTICS

PARAMETER	SYMBOL	V <sub>CC</sub> (V)	CONDITIONS	Ta=25°C			Ta=-40°C~85°C		UNITS	
				MIN.	TYP.	MAX.	MIN.	MAX.		
Input Voltage	V <sub>IH</sub>	2.0		1.5	—	—	1.5	—	V	
		3.0		2.1	—	—	2.1	—		
		5.5		3.85	—	—	3.85	—		
	V <sub>IL</sub>	2.0		—	—	0.5	—	0.5	V	
		3.0		—	—	0.9	—	0.9		
		5.5		—	—	1.65	—	1.65		
Output Voltage	V <sub>OH</sub>	2.0	V <sub>IN</sub> =V <sub>IH</sub>	I <sub>OH</sub> =-50 μA	1.9	2.0	—	1.9	—	V
		3.0			2.9	3.0	—	2.9	—	
		4.5		4.4	4.5	—	4.4	—		
		3.0		I <sub>OH</sub> =-4mA	2.58	—	—	2.48	—	
	4.5	I <sub>OH</sub> =-8mA	3.94	—	—	3.80	—			
	V <sub>OL</sub>	2.0	V <sub>IN</sub> =V <sub>IH</sub> or V <sub>IL</sub>	I <sub>OL</sub> =50 μA	—	—	0.1	—	0.1	V
					3.0	—	—	0.1	—	
		4.5		—	—	0.1	—	0.1		
		3.0		I <sub>OL</sub> =4mA	—	—	0.36	—	0.44	
		4.5		I <sub>OL</sub> =8mA	—	—	0.36	—	0.44	
5.5		V <sub>IN</sub> =V <sub>CC</sub> or GND		-0.1	—	0.1	-1.0	1.0	μA	
Static Supply Current	I <sub>CC</sub>	5.5	V <sub>IN</sub> =V <sub>CC</sub> or GND, I <sub>OUT</sub> =0 μA	—	—	1.0	—	10.0		

## SWITCHING ELECTRICAL CHARACTERISTICS

t<sub>r</sub>=t<sub>f</sub>=3ns

PARAMETER	SYMBOL	C <sub>L</sub>	V <sub>CC</sub> (V)	CONDITIONS	Ta=25°C			Ta=-40°C~85°C		UNITS
					MIN.	TYP.	MAX.	MIN.	MAX.	
Delay Time	t <sub>PLH</sub>	15pF	3.3		—	3.7	8.8	1.0	10.5	ns
			5.0		—	2.8	5.9	1.0	7.0	
		50pF	3.3		—	5.2	12.3	1.0	14.0	ns
			5.0		—	3.7	7.9	1.0	9.0	
	t <sub>PHL</sub>	15pF	3.3		—	3.2	8.8	1.0	10.5	ns
			5.0		—	2.4	5.9	1.0	7.0	
		50pF	3.3		—	4.5	12.3	1.0	14.0	ns
			5.0		—	3.4	7.9	1.0	9.0	
Input Capacitance	C <sub>IN</sub>	—	5.0	V <sub>IN</sub> =V <sub>CC</sub> or GND	—	4	10	—	10	pF
Power Dissipation Capacitance	C <sub>pd</sub>	No Load, f=1MHz			—	9.3	—	—	—	pF

## WAVEFORM

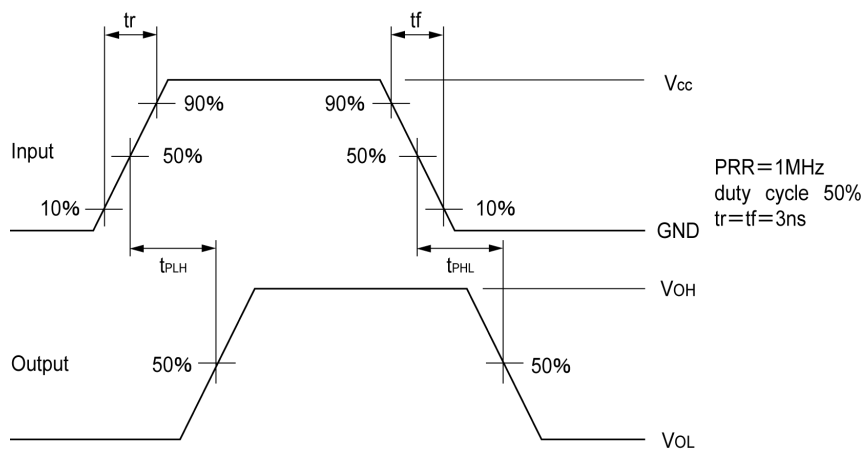

## TEST CIRCUIT

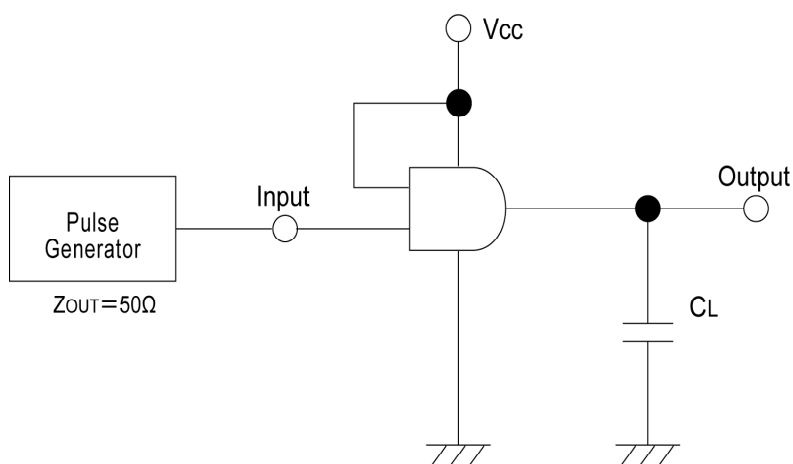

Note: Open output when measuring supply current