

3.3V ABT 16-bit transceiver with 30Ω termination resistors (3-State)

74LVT16245B-1

FEATURES

- 16-bit bidirectional bus interface
- 3-State buffers
- Output capability: +12mA/-32mA
- TTL input and output switching levels
- Input and output interface capability to systems at 5V supply
- Bus-hold data inputs eliminate the need for external pull-up resistors to hold unused inputs
- Live insertion/extraction permitted
- Outputs include series resistance of 30Ω making external termination resistors unnecessary

- Power-up 3-State
- No bus current loading when output is tied to 5V bus
- Latch-up protection exceeds 500mA per JEDEC JC40.2 Std 17
- ESD protection exceeds 2000V per MIL STD 883 Method 3015 and 200V per Machine Model

This device is a 16-bit transceiver featuring non-inverting 3-State bus compatible outputs in both send and receive directions. The control function implementation minimizes external timing requirements. The device features an Output Enable (nOE) input for easy cascading and a Direction (nDIR) input for direction control.

The LVT16245B-1 is designed with 30Ω series resistance in both the High and Low states of the output. This design reduces line noise in applications such as memory address drivers, clock drivers, and bus transceivers/transmitters.

DESCRIPTION

The LVT16245B-1 is a high-performance BiCMOS product designed for V_{CC} operation at 3.3V.

QUICK REFERENCE DATA

SYMBOL	PARAMETER	CONDITIONS T _{amb} = 25°C; GND = 0V	TYPICAL	UNIT
t _{PLH} t _{PHL}	Propagation delay nAx to nBx or nBx to nAx	C _L = 50pF; V _{CC} = 3.3V		ns
C _{IN}	Input capacitance DIR, OE	V _I = 0V or 3.0V	4	pF
C _{I/O}	I/O pin capacitance	Outputs disabled; V _{I/O} = 0V or 3.0V	10	pF
I _{CCZ}	Total supply current	Outputs disabled; V _{CC} = 3.6V	100	μA

ORDERING INFORMATION

PACKAGES	TEMPERATURE RANGE	ORDER CODE	DRAWING NUMBER
48-Pin Plastic Shrink Small Outline (SSOP) Type III	-40°C to +85°C	74LVT16245B-1DL	SOT370-1
48-Pin Plastic Thin Shrink Small Outline (TSSOP) Type II	-40°C to +85°C	74LVT16245B-1DGG	SOT362-1

LOGIC SYMBOL

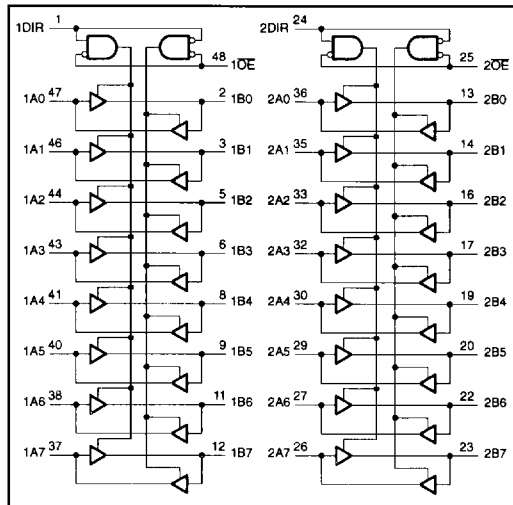

LOGIC SYMBOL (IEEE/IEC)

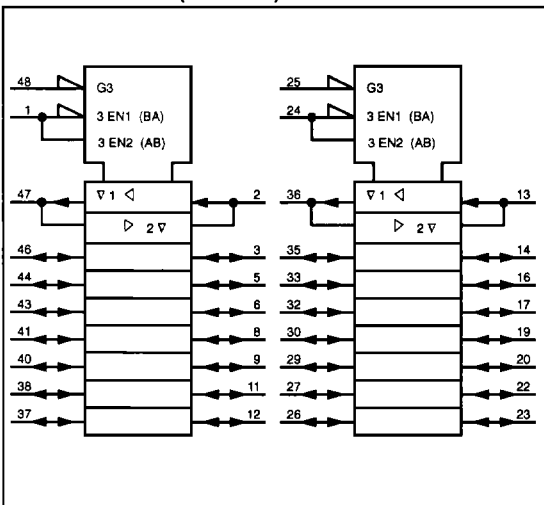

3.3V ABT 16-bit transceiver with 30Ω termination resistors (3-State)

74LVT16245B-1

PIN CONFIGURATION

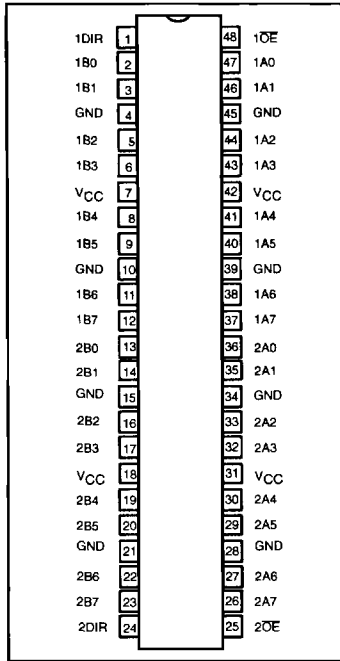

SCHEMATIC OF EACH OUTPUT

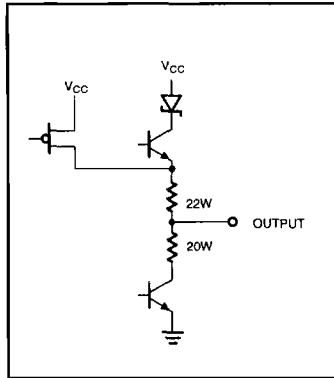

PIN DESCRIPTION

PIN NUMBER	SYMBOL	NAME AND FUNCTION
1, 24	nDIR	Direction control input
47, 46, 44, 43, 41, 40, 38, 37, 36, 35, 33, 32, 30, 29, 27, 26	nA0 – nA7	Data inputs/outputs (A side)
2, 3, 5, 6, 8, 9, 11, 12, 13, 14, 16, 17, 19, 20, 22, 23	nB0 – nB7	Data inputs/outputs (B side)
25, 48	\overline{nOE}	Output enable input (active-Low)
4, 10, 15, 21, 28, 34, 39, 45	GND	Ground (0V)
7, 18, 31, 42	V _{CC}	Positive supply voltage

FUNCTION TABLE

Inputs		Inputs/Outputs	
nOE	nDIR	nAx	nBx
L	L	nAx = nBx	Inputs
L	H	Inputs	nBx = nAx
H	X	Z	Z

H = High voltage level
 L = Low voltage level
 X = Don't care
 Z = High Impedance "off" state

3.3V ABT 16-bit transceiver with 30Ω termination resistors (3-State)

74LVT16245B-1

ABSOLUTE MAXIMUM RATINGS^{1,2}

SYMBOL	PARAMETER	CONDITIONS	RATING	UNIT
V _{CC}	DC supply voltage		-0.5 to +4.6	V
I _{IK}	DC input diode current	V _I < 0	-50	mA
V _I	DC input voltage ³		-0.5 to +7.0	V
I _{OK}	DC output diode current	V _O < 0	-50	mA
V _{OUT}	DC output voltage ³	Output in Off or High state	-0.5 to +7.0	V
I _{OUT}	DC output current	Output in Low state	128	mA
		Output in High state	-64	
T _{stg}	Storage temperature range		-65 to +150	°C

NOTES:

- Stresses beyond those listed may cause permanent damage to the device. These are stress ratings only and functional operation of the device at these or any other conditions beyond those indicated under "recommended operating conditions" is not implied. Exposure to absolute-maximum-rated conditions for extended periods may affect device reliability.
- The performance capability of a high-performance integrated circuit in conjunction with its thermal environment can create junction temperatures which are detrimental to reliability. The maximum junction temperature of this integrated circuit should not exceed 150°C.
- The input and output negative voltage ratings may be exceeded if the input and output clamp current ratings are observed.

RECOMMENDED OPERATING CONDITIONS

SYMBOL	PARAMETER	LIMITS		UNIT
		MIN	MAX	
V _{CC}	DC supply voltage	2.7	3.6	V
V _I	Input voltage	0	5.5	V
V _{IH}	High-level input voltage	2.0		V
V _{IL}	Input voltage		0.8	V
I _{OH}	High-level output current		-32	mA
I _{OL}	Low-level output current		12	mA
Δt/Δv	Input transition rise or fall rate; Outputs enabled		10	ns/V
T _{amb}	Operating free-air temperature range	-40	+85	°C

3.3V ABT 16-bit transceiver with 30Ω termination resistors (3-State)

74LVT16245B-1

DC ELECTRICAL CHARACTERISTICS

SYMBOL	PARAMETER	TEST CONDITIONS	LIMITS			UNIT
			Temp = -40°C to +85°C			
			MIN	TYP ¹	MAX	
V _{IK}	Input clamp voltage	V _{CC} = 2.7V; I _{IK} = -18mA			-1.2	V
V _{OH}	High-level output voltage	V _{CC} = 3.0V; I _{OH} = -12mA	2.0			V
V _{OL}	Low-level output voltage	V _{CC} = 3.0V; I _{OL} = 12mA			0.8	V
I _I	Input leakage current	V _{CC} = 3.6V; V _I = V _{CC} or GND	Control pins		±1	μA
		V _{CC} = 0 or 3.6V; V _I = 5.5V			10	
		V _{CC} = 3.6V; V _I = V _{CC}	I/O Data pins ⁴		10	
		V _{CC} = 3.6V; V _I = 0			-5	
I _{OFF}	Output off current	V _{CC} = 0V; V _I or V _O = 0 to 4.5V			±100	μA
I _{HOLD}	Bus Hold current A or B outputs	V _{CC} = 3V; V _I = 0.8V		75		μA
		V _{CC} = 3V; V _I = 2.0V		-75		
I _{EX}	Current into an output in the High state when V _O > V _{CC}	V _O = 5.5V; V _{CC} = 3.0V			125	μA
I _{PU/PD}	Power up/down 3-State output current ³	V _{CC} ≤ 1.2V; V _O = 0.5V to V _{CC} ; V _I = GND or V _{CC} ; OE/OE = Don't care			±100	μA
I _{CCH}	Quiescent supply current	V _{CC} = 3.6V; Outputs High, V _I = GND or V _{CC} , I _O = 0			0.12	mA
I _{CCL}		V _{CC} = 3.6V; Outputs Low, V _I = GND or V _{CC} , I _O = 0			5	
I _{CCZ}		V _{CC} = 3.6V; Outputs Disabled; V _I = GND or V _{CC} , I _O = 0			0.12	
ΔI _{CC}	Additional supply current per input pin ²	V _{CC} = 3V to 3.6V; One input at V _{CC} -0.6V, Other inputs at V _{CC} or GND			0.2	mA

NOTES:

- All typical values are at V_{CC} = 3.3V and T_{amb} = 25°C.
- This is the increase in supply current for each input at the specified voltage level other than V_{CC} or GND.
- This parameter is valid for any V_{CC} between 0V and 1.2V with a transition time of up to 10msec. From V_{CC} = 1.2V to V_{CC} = 3.3V ± 0.3V a transition time of 100μsec is permitted. This parameter is valid for T_{amb} = 25°C only.
- Unused pins at V_{CC} or GND.

AC CHARACTERISTICS

GND = 0V; t_R = t_F = 2.5ns; C_L = 50pF; R_L = 500Ω; T_{amb} = -40°C to +85°C.

SYMBOL	PARAMETER	WAVEFORM	LIMITS				UNIT
			V _{CC} = 3.3V ±0.3V		V _{CC} = 2.7V		
			MIN	TYP ¹	MAX	MAX	
t _{PLH} t _{PHL}	Propagation delay nAx to bBx or bBx to nAx	1					ns
t _{PZH} t _{PZL}	Output enable time to High and Low level	2					ns
t _{PHZ} t _{PLZ}	Output disable time from High and Low Level	2					ns

NOTE:

- All typical values are at V_{CC} = 3.3V and T_{amb} = 25°C.

3.3V ABT 16-bit transceiver with 30Ω termination resistors (3-State)

74LVT16245B-1

AC WAVEFORMS

$V_M = 1.5V$, $V_{IN} = GND$ to 2.7V

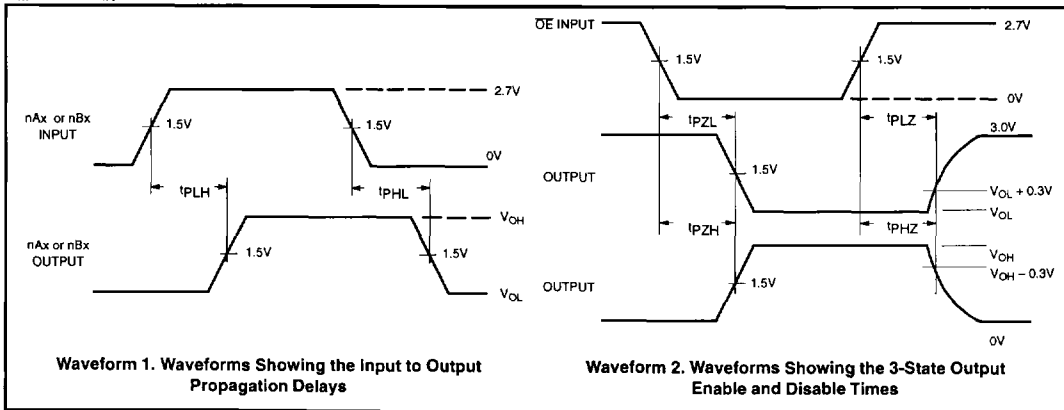

TEST CIRCUIT AND WAVEFORMS

