

Dual Four-Input NAND Gates

Product Specification

Military Logic Products

FUNCTION TABLE

INPUTS				OUTPUT
A	B	C	D	Y
L	X	X	X	H
X	L	X	X	H
X	X	L	X	H
X	X	X	L	H
H	H	H	H	L

H = High voltage level
L = Low voltage level
X = Don't care

ORDERING INFORMATION

DESCRIPTION	ORDER CODE
Ceramic DIP	54LS20/BCA, 54S20/BCA
Ceramic Flat Pack	54LS20/BDA, 54S20/BDA
Ceramic LLCC	54LS20/B2A, 54S20/B2A

INPUT AND OUTPUT LOADING AND FAN-OUT TABLE

PINS	DESCRIPTION	54S	54LS
A - D	Inputs	1SUL	1LSUL
Y	Output	10SUL	10LSUL

NOTE: Where a 54S Unit Load (SUL) is 50 μ A I_{IH} and -2.0mA I_{IL} , and a 54LS Unit Load (LSUL) is 20 μ A I_{IH} and -0.4mA I_{IL} .

ABSOLUTE MAXIMUM RATINGS (Over operating free-air temperature range unless otherwise noted.)

SYMBOL	PARAMETER	54LS	54S	UNIT
V_{CC}	Supply voltage	7.0	7.0	V
V_I	Input voltage range	-0.5 to +7.0	-0.5 to +5.5	V
I_I	Input current range	-30 to +1	-30 to +5	mA
V_O	Voltage applied to output in High output state range	-0.5 to + V_{CC}	-0.5 to + V_{CC}	V
T_{STG}	Storage temperature range	-65 to +150	-65 to +150	$^{\circ}$ C

PIN CONFIGURATION

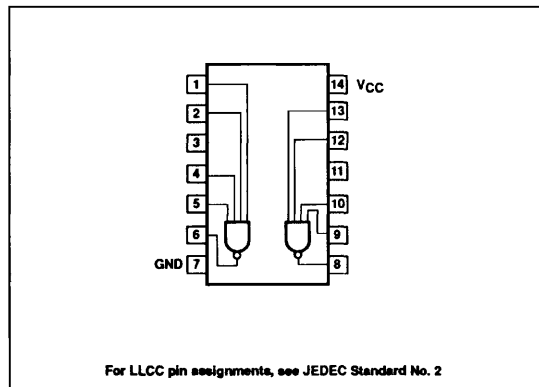

LOGIC SYMBOL

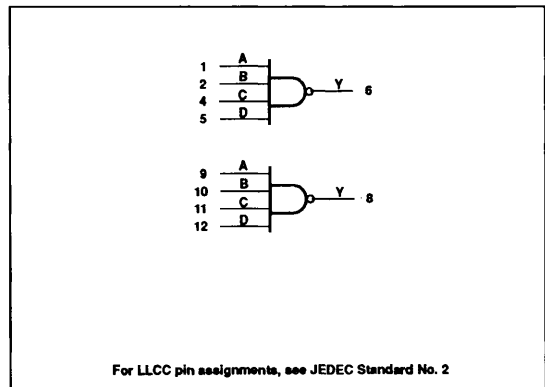

Gates

54LS20, 54S20

RECOMMENDED OPERATING CONDITIONS

SYMBOL	PARAMETER	54LS			54S			UNIT
		Min	Nom	Max	Min	Nom	Max	
V_{CC}	Supply voltage	4.5	5.0	5.5	4.5	5.0	5.5	V
V_{IH}	High-level input voltage	2.0			2.0			V
V_{IL}	Low-level input voltage			+0.7			+0.8	V
		+125°C		+0.7			+0.7	V
I_{IK}	Input clamp current			-18			-18	mA
I_{OH}	High-level output current			-400			-1000	μA
I_{OL}	Low-level output current			4			20	mA
T_A	Operating free-air temperature range	-55		+125	-55		+125	°C

DC ELECTRICAL CHARACTERISTICS (Over recommended operating free-air temperature range unless otherwise noted.)

SYMBOL	PARAMETER	TEST CONDITIONS ¹	54LS20			54S20			UNIT
			Min	Typ ²	Max	Min	Typ ²	Max	
V_{OH}	High-level output voltage	$V_{CC} = \text{Min}, V_{IL} = \text{Max}, V_{IH} = \text{Min}, I_{OH} = \text{Max}$	2.5	3.4		2.5	3.4		V
V_{OL}	Low-level output voltage	$V_{CC} = \text{Min}, V_{IH} = \text{Min}, V_{IL} = \text{Max}, I_{OL} = \text{Max}$		0.25	0.4			0.5	V
			+125°C			0.4			0.4
V_{IK}	Input clamp voltage	$V_{CC} = \text{Min}, I_I = I_{IK}$			-1.5			-1.2	V
I_{IH2}	Input current at maximum input voltage	$V_{CC} = \text{Max}$	$V_I = 5.5\text{V}$					1.0	mA
			$V_I = 7.0\text{V}$			0.1			
I_{IH1}	High-level input current	$V_{CC} = \text{Max}, V_I = 2.7\text{V}$			20			50	μA
I_{IL}	Low-level input current	$V_{CC} = \text{Max}$	$V_I = 0.4\text{V}$		-0.4				mA
			$V_I = 0.5\text{V}$					-2.0	mA
I_{OS}	Short-circuit output current ³	$V_{CC} = \text{Max}$	-20		-100	-40		-110	mA
I_{CC}	Supply current (total)	$V_{CC} = \text{Max}$	I_{CCH} Outputs High	0.4	0.8		5	8	mA
			I_{CCL} Outputs Low	1.2	2.2		10	18	mA

AC ELECTRICAL CHARACTERISTICS $T_A = 25^\circ\text{C}, V_{CC} = 5.0\text{V}^4$

SYMBOL	PARAMETER	TEST CONDITIONS	54LS		54S		UNIT
			$C_L = 15\text{pF}$		$C_L = 15\text{pF}$		
			Min	Max	Min	Max	
t_{PLH} t_{PHL}	Propagation delay	Waveform 1		15 15		4.5 5.0	ns ns

AC ELECTRICAL CHARACTERISTICS $T_A = 25^\circ\text{C}, V_{CC} = 5.0\text{V}$

SYMBOL	PARAMETER	TEST CONDITIONS	54LS		54S		UNIT
			$C_L = 50\text{pF}$		$C_L = 50\text{pF}$		
			Min	Max	Min	Max	
t_{PLH} t_{PHL}	Propagation delay	Waveform 1		20 20		7.0 7.5	ns ns

Gates

54LS20, 54S20

AC ELECTRICAL CHARACTERISTICS $T_A = -55^\circ\text{C}$ and $+125^\circ\text{C}$, $V_{CC} = 5.0\text{V}^4$

SYMBOL	PARAMETER	TEST CONDITIONS	54LS		54S		UNIT
			$C_L = 50\text{pF}$		$C_L = 50\text{pF}$		
			Min	Max	Min	Max	
t_{PLH} t_{PHL}	Propagation delay	Waveform 1		26 26		9.0 9.0	ns ns

NOTES:

1. For conditions shown as Min or Max, use the appropriate value specified under recommended operating conditions for the applicable type and function table operating mode.
2. All typical values are at $V_{CC} = 5\text{V}$, $T_A = 25^\circ\text{C}$.
3. Not more than one output should be shorted at a time and duration of the short circuit should not exceed one second.
4. These parameters are guaranteed, but not tested.

AC WAVEFORM

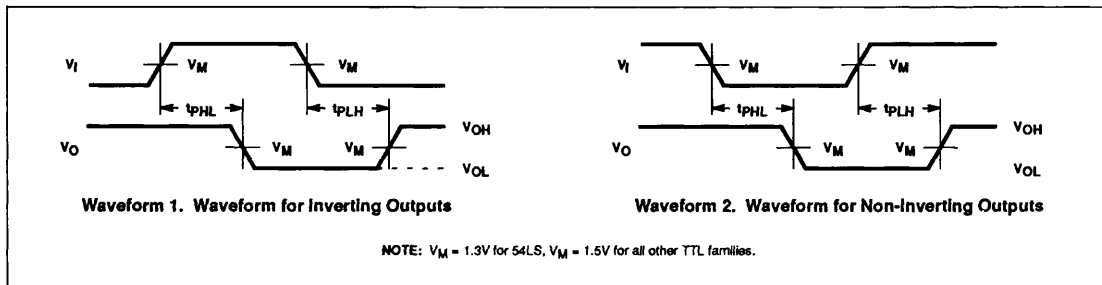

TEST CIRCUIT AND WAVEFORM

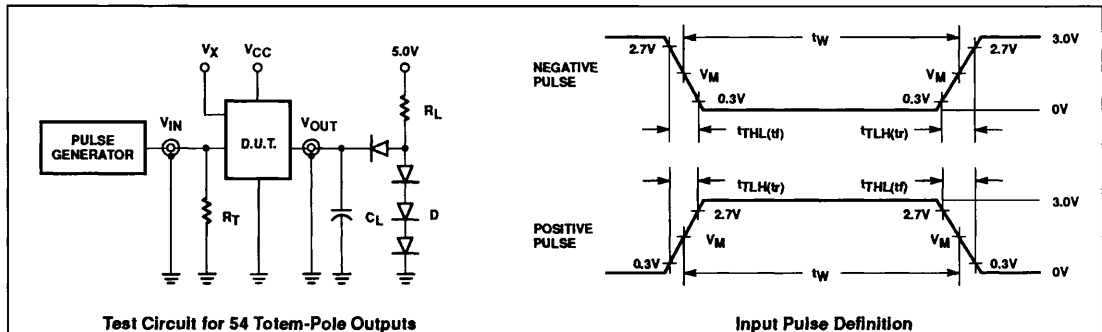

FAMILY	INPUT PULSE CHARACTERISTICS					
	R_L	V_M	Rep. Rate	T_W	T_{TLH}	T_{THL}
54LSXXX	2.0k Ω	1.3V	1MHz	500ns	$\leq 15\text{ns}$	$\leq 6\text{ns}$
54SXXX	280 Ω	1.5V	1MHz	500ns	$\leq 2.5\text{ns}$	$\leq 2.5\text{ns}$

DEFINITIONS:

- C_L = Load capacitance includes jig and probe capacitance; see AC Characteristics for value.
- R_T = Termination resistance should be equal to Z_{OUT} of Pulse Generators.
- D = Diodes are 1N916, 1N3064, or equivalent.
- V_X = Undocked pins must be held at $\leq 0.8\text{V}$, $\geq 2.7\text{V}$ or open per Function Table.