

Fast CMOS Dual 1-of-4 Decoder

Product Features

- PI74FCT139/239T is pin compatible with bipolar FAST™ Series at a higher speed and lower power consumption
- TTL input and output levels
- Extremely low static power
- Hysteresis on all inputs
- Industrial operating temperature range: -40°C to +85°C
- Packages available:
 - 16-pin 150 mil wide plastic QSOP (Q)
 - 16-pin 300 mil wide plastic SOIC (S)
 - 16-pin 150 mil wide plastic SOIC (W)

Product Description

Pericom Semiconductor's PI74FCT series of logic circuits are produced in the Company's advanced 0.8 micron CMOS technology, achieving industry leading speed grades.

These are high-speed two independent 1-of-4 decoders. Each decoder accepts two binary weighted inputs (A0, A1) and gives four mutually exclusive active LOW outputs (O0-O3: PI74FCT139T) or active HIGH outputs (O0-O3: PI74FCT239T). There is one active LOW enable (E) for each decoder. For the PI74FCT139T all outputs are forced HIGH, and for the PI74FCT239T all outputs are forced LOW when E is HIGH.

Logic Block Diagram

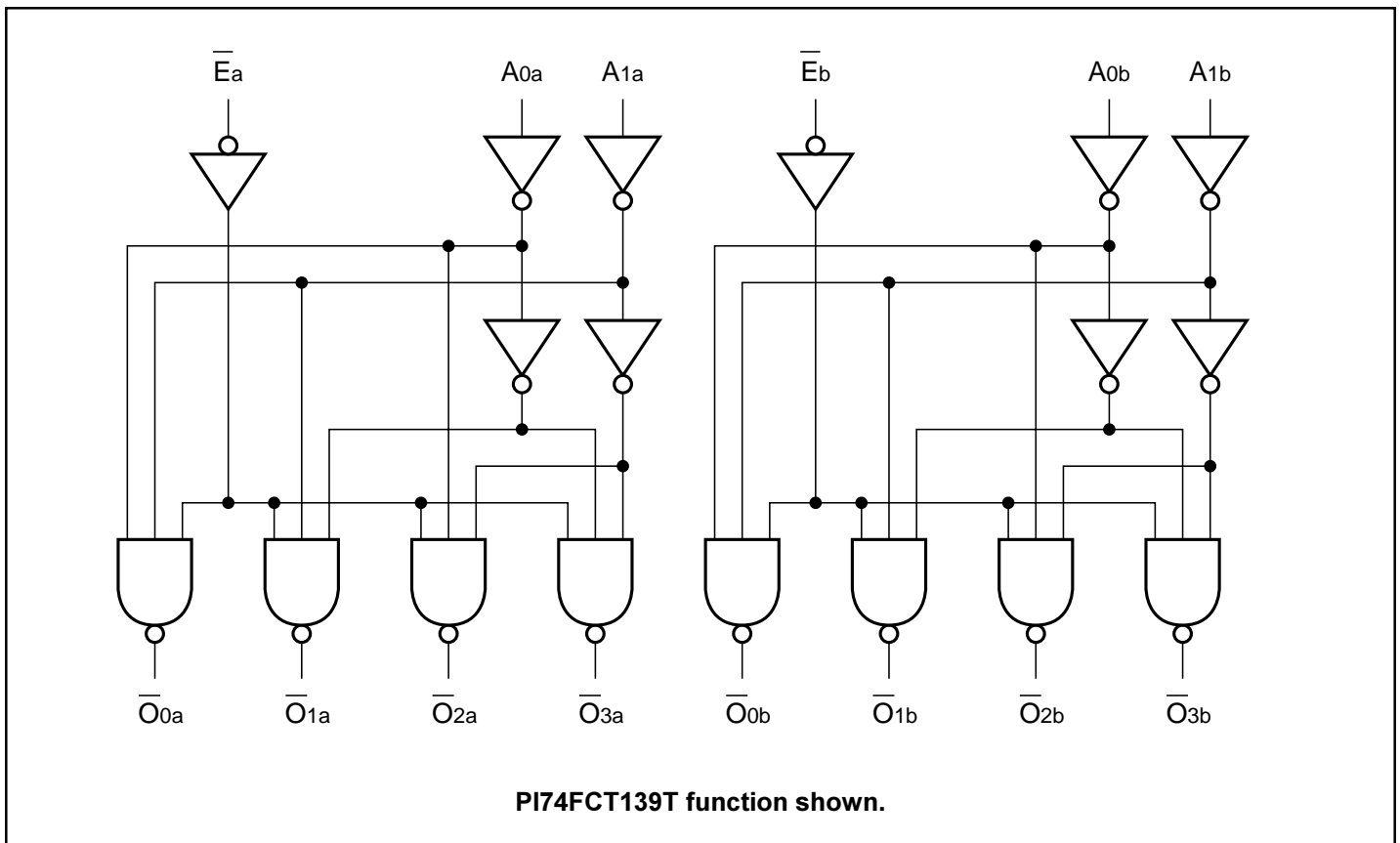

PI74FCT139T Product Pin Configuration

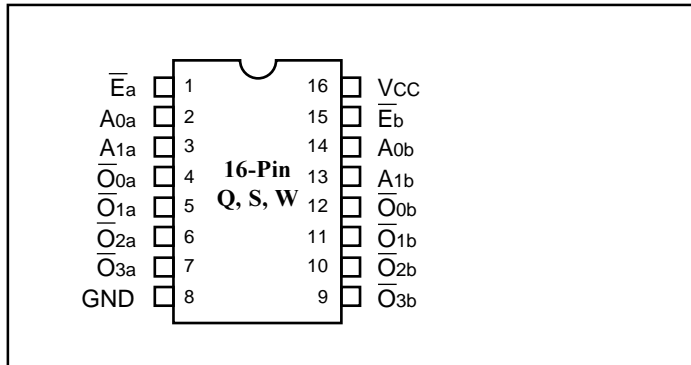

PI74FCT139T Product Pin Description

Pin Name	Description
A0, A1	Address Inputs
\bar{E}	Enable Input (Active LOW)
$\bar{O}0\text{-}\bar{O}3$	Outputs (Active LOW)

PI74FCT139T Truth Table ⁽¹⁾

Inputs			Outputs			
\bar{E}	A0	A1	$\bar{O}0$	$\bar{O}1$	$\bar{O}2$	$\bar{O}3$
H	X	X	H	H	H	H
L	L	L	L	H	H	H
L	H	L	H	L	H	H
L	L	H	H	H	L	H
L	H	H	H	H	H	L

Note:

1. H = HIGH Voltage Level
L = LOW Voltage Level
X = Don't Care

PI74FCT239T Truth Table ⁽¹⁾

Inputs			Outputs			
\bar{E}	A0	A1	O0	O1	O2	O3
H	X	X	L	L	L	L
L	L	L	H	L	L	L
L	H	L	L	H	L	L
L	L	H	L	L	H	L
L	H	H	L	L	L	H

Note:

1. H = HIGH Voltage Level
L = LOW Voltage Level
X = Don't Care

PI74FCT239T Product Pin Configuration

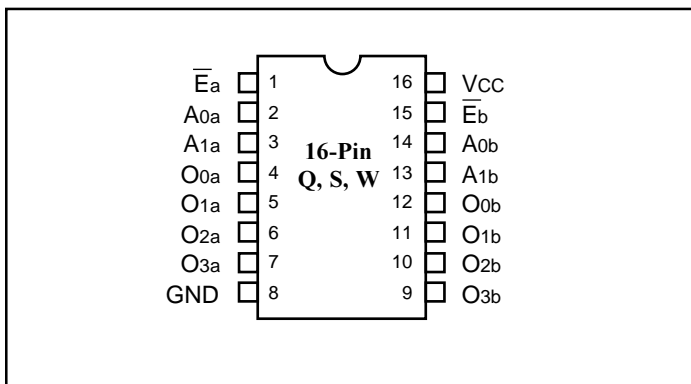

PI74FCT239T Product Pin Description

Pin Name	Description
A0, A1	Address Inputs
\bar{E}	Enable Input (Active LOW)
O0-O3	Outputs (Active HIGH)

Maximum Ratings

(Above which the useful life may be impaired. For user guidelines, not tested.)

Storage Temperature	-65°C to +150°C
Ambient Temperature with Power Applied	-40°C to +85°C
Supply Voltage to Ground Potential (Inputs & Vcc Only)	-0.5V to +7.0V
Supply Voltage to Ground Potential (Outputs & D/O Only)	-0.5V to +7.0V
DC Input Voltage	-0.5V to +7.0V
DC Output Current	120 mA
Power Dissipation	0.5W

Note:

Stresses greater than those listed under MAXIMUM RATINGS may cause permanent damage to the device. This is a stress rating only and functional operation of the device at these or any other conditions above those indicated in the operational sections of this specification is not implied. Exposure to absolute maximum rating conditions for extended periods may affect reliability.

DC Electrical Characteristics (Over the Operating Range, TA = -40°C to +85°C, VCC = 5.0V ± 5%)

Parameters	Description	Test Conditions ⁽¹⁾		Min.	Typ ⁽²⁾	Max.	Units
V _{OH}	Output HIGH Voltage	V _{CC} = Min., V _{IN} = V _{IH} or V _{IL}	I _{OH} = -15.0 mA	2.4	3.0		V
V _{OL}	Output LOW Current	V _{CC} = Min., V _{IN} = V _{IH} or V _{IL}	I _{OL} = 48 mA		0.3	0.50	V
V _{IH}	Input HIGH Voltage	Guaranteed Logic HIGH Level		2.0			V
V _{IL}	Input LOW Voltage	Guaranteed Logic LOW Level				0.8	V
I _{IH}	Input HIGH Current	V _{CC} = Max.	V _{IN} = V _{CC}			1	μA
I _{IL}	Input LOW Current	V _{CC} = Max.	V _{IN} = GND			-1	μA
V _{IK}	Clamp Diode Voltage	V _{CC} = Min., I _{IN} = -18 mA			-0.7	-1.2	V
I _{OS}	Short Circuit Current	V _{CC} = Max. ⁽³⁾ , V _{OUT} = GND		-60	-120	-225	mA
I _{OFF}	Power Down Disable	V _{CC} = GND, V _{OUT} = 4.5V		—	—	100	μA
V _H	Input Hysteresis				200		mV

Capacitance (TA = 25°C, f = 1 MHz)

Parameters ⁽⁴⁾	Description	Test Conditions	Typ	Max.	Units
C _{IN}	Input Capacitance	V _{IN} = 0V	6	10	pF
C _{OUT}	Output Capacitance	V _{OUT} = 0V	8	12	pF

Notes:

1. For Max. or Min. conditions, use appropriate value specified under Electrical Characteristics for the applicable device type.
2. Typical values are at V_{CC} = 5.0V, +25°C ambient and maximum loading.
3. Not more than one output should be shorted at one time. Duration of the test should not exceed one second.
4. This parameter is determined by device characterization but is not production tested.

Power Supply Characteristics

Parameters	Description	Test Conditions ⁽¹⁾		Min.	Typ ⁽²⁾	Max.	Units
I _{CC}	Quiescent Power Supply Current	V _{CC} = Max.	V _{IN} = GND or V _{CC}		0.1	500	μA
ΔI _{CC}	Supply Current per Input @ TTL HIGH	V _{CC} = Max.	V _{IN} = 3.4V ⁽³⁾		0.5	2.0	mA
I _{CCD}	Supply Current per Input per MHz ⁽⁴⁾	V _{CC} = Max. Outputs Open One Input Toggling 50% Duty Cycle	V _{IN} = V _{CC} V _{IN} = GND		0.15	0.3	mA/ MHz
I _C	Total Power Supply Current ⁽⁶⁾	V _{CC} = Max. Outputs Open f _{CP} = 10 MHz 50% Duty Cycle One Bit toggling	V _{IN} = V _{CC} V _{IN} = GND		1.5	4.0	mA
			V _{IN} = 3.4V V _{IN} = GND		1.8	5.0	
		V _{CC} = Max., Outputs Open f _{CP} = 10 MHz 50% Duty Cycle One Bit toggling on Each Decoder	V _{IN} = V _{CC} V _{IN} = GND		3.0	7.5 ⁽⁵⁾	
			V _{IN} = 3.4V V _{IN} = GND		3.7	9.5 ⁽⁵⁾	

Notes:

1. For Max. or Min. conditions, use appropriate value specified under Electrical Characteristics for the applicable device.
2. Typical values are at V_{CC} = 5.0V, +25°C ambient.
3. Per TTL driven input (V_{IN} = 3.4V); all other inputs at V_{CC} or GND.
4. This parameter is not directly testable, but is derived for use in Total Power Supply Calculations.
5. Values for these conditions are examples of the I_{CC} formula. These limits are guaranteed but not tested.
6. I_C = I_{QUIESCENT} + I_{INPUTS} + I_{DYNAMIC}

$$I_C = I_{CC} + \Delta I_{CC} D_H N_T + I_{CCD} (f_{CP}/2 + f_i N_i)$$

I_{CC} = Quiescent Current

ΔI_{CC} = Power Supply Current for a TTL High Input (V_{IN} = 3.4V)

D_H = Duty Cycle for TTL Inputs High

N_T = Number of TTL Inputs at D_H

I_{CCD} = Dynamic Current Caused by an Input Transition Pair (HLH or LHL)

f_{CP} = Clock Frequency for Register Devices (Zero for Non-Register Devices)

f_o = Output Frequency

N_o = Number of Outputs at f_o

All currents are in milliamps and all frequencies are in megahertz.

PI74FCT139T Switching Characteristics over Operating Range

Parameters	Description	Conditions ⁽¹⁾	139T		139AT		139CT		139DT		Unit
			Com.		Com.		Com.		Com.		
			Min	Max	Min	Max	Min	Max	Min	Max	
t _{PLH} t _{PHL}	Propagation Delay A ₀ or A ₁ to \bar{O}_n	C _L = 50 pF R _L = 500ohm	1.5	9.0	1.5	5.9	1.5	5.0	1.0	4.0	ns
t _{PLH} t _{PHL}	Propagation Delay \bar{E} to \bar{O}_n		1.5	8.0	1.5	5.5	1.5	4.8	1.0	4.0	ns

Notes:

1. See test circuit and wave forms.
2. Minimum limits are guaranteed but not tested on Propagation Delays.

PI74FCT239T Switching Characteristics over Operating Range

Parameters	Description	Conditions ⁽¹⁾	239T		239AT		239CT		Unit
			Com.		Com.		Com.		
			Min	Max	Min	Max	Min	Max	
t _{PLH} t _{PHL}	Propagation Delay A ₀ or A ₁ to O _n	C _L = 50 pF R _L = 500ohm	1.5	9.0	1.5	5.9	1.5	5.0	ns
t _{PLH} t _{PHL}	Propagation Delay \bar{E} to O _n		1.5	8.0	1.5	5.5	1.5	4.8	ns

Notes:

1. See test circuit and wave forms.
2. Minimum limits are guaranteed but not tested on Propagation Delays.

Packaging Mechanical: 16-Pin QSOP (Q)

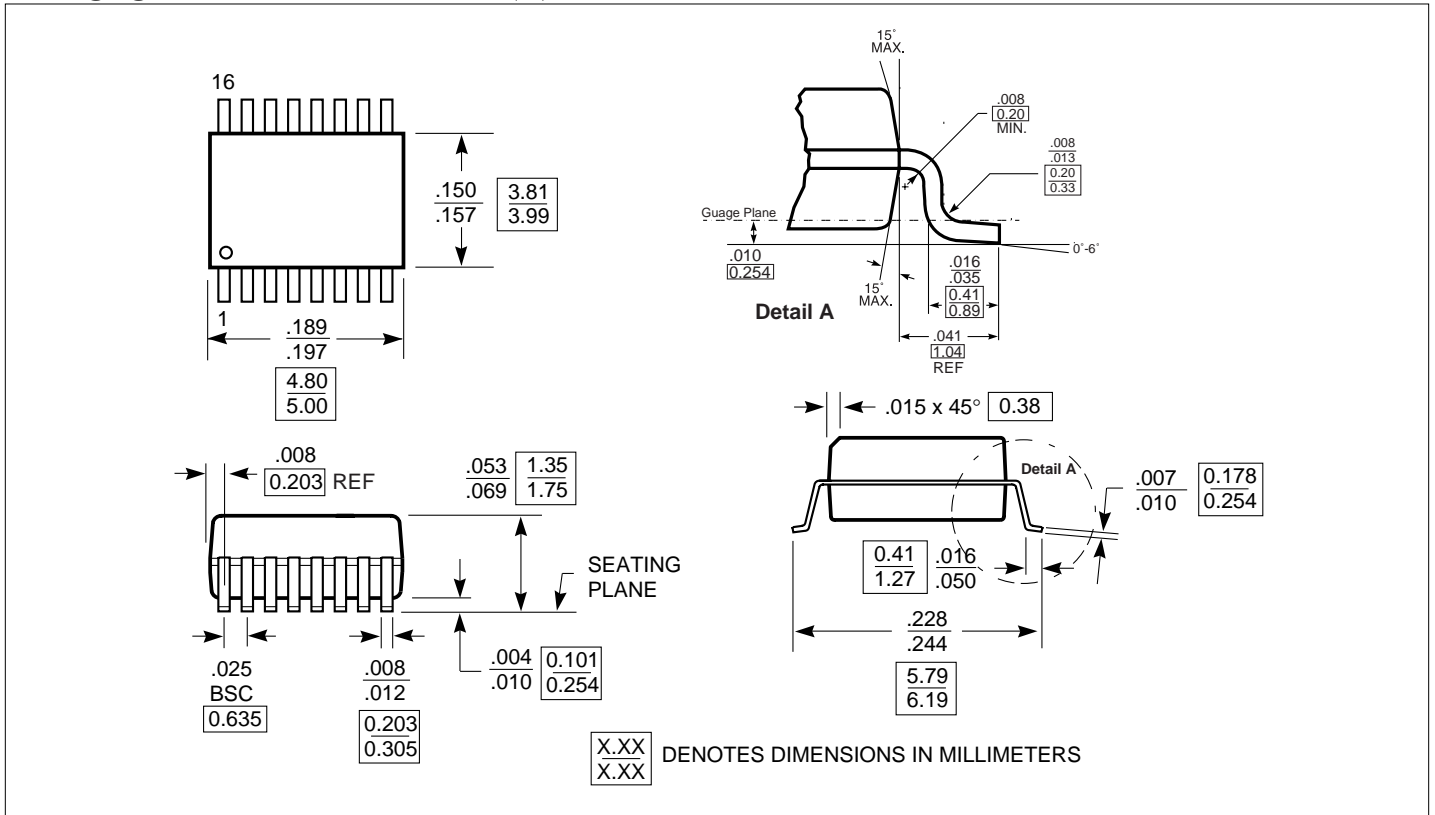

Packaging Mechanical: 16-Pin SOIC (S)

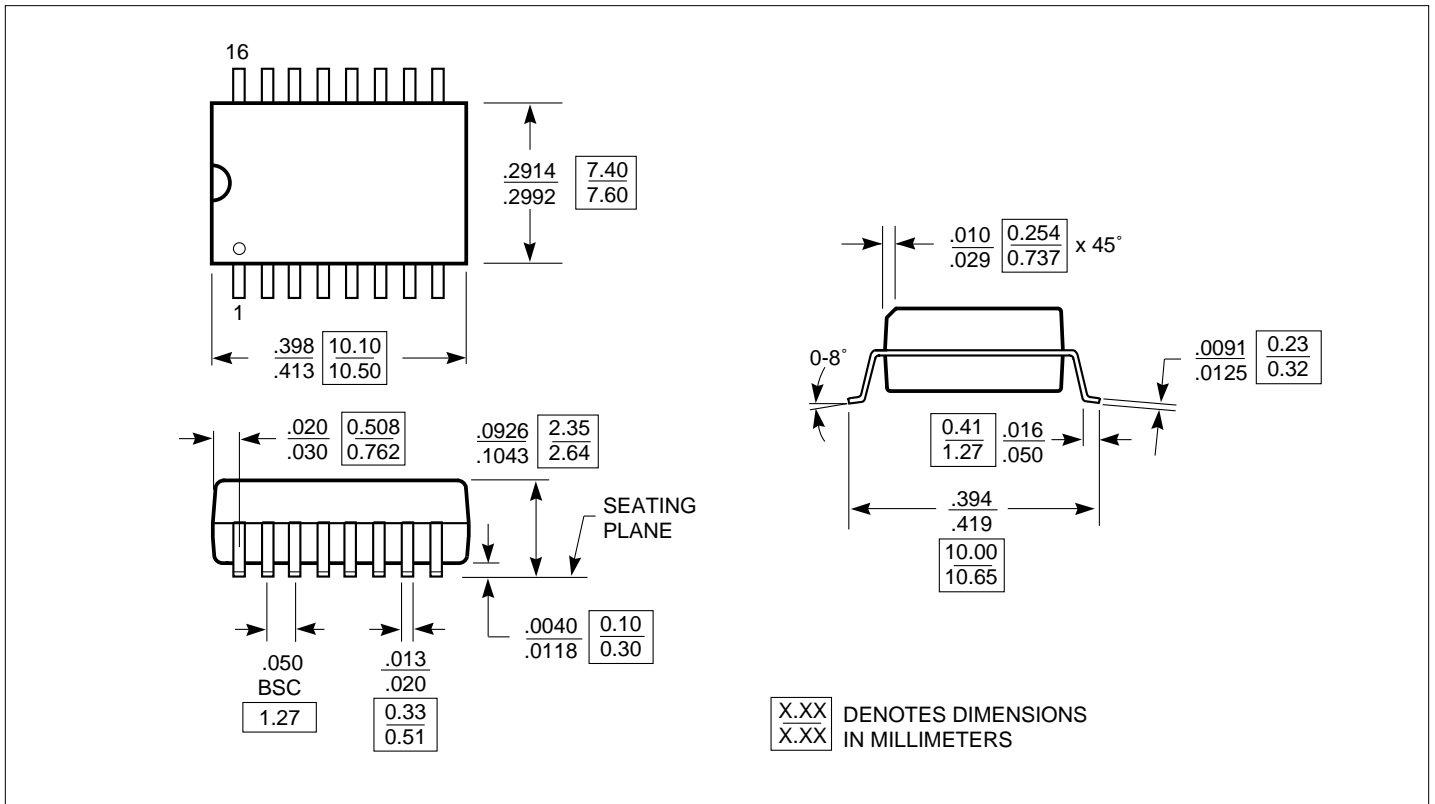

Packaging Mechanical: 16-Pin SOIC (W)

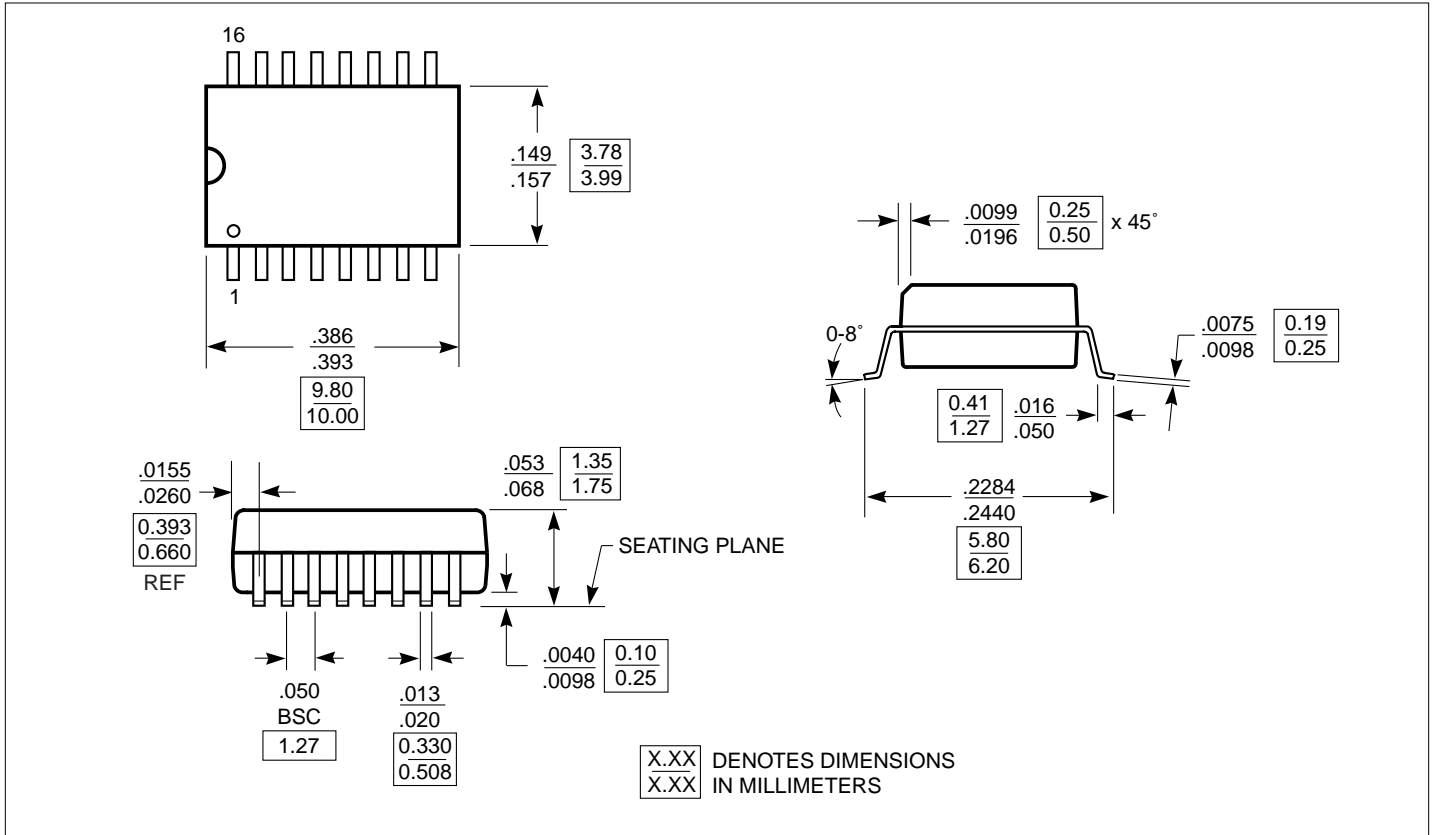

Ordering Information

Part	Operating Range
PI74FCT139TQ	16-pin 150 mil wide plastic QSOP (Q)
PI74FCT139TS	16-pin 300 mil wide plastic SOIC (S)
PI74FCT139TW	16-pin 150 mil wide plastic SOIC (W)
PI74FCT239TQ	16-pin 150 mil wide plastic QSOP (Q)
PI74FCT239TS	16-pin 300 mil wide plastic SOIC (S)
PI74FCT239TW	16-pin 150 mil wide plastic SOIC (W)

Part Marking Information

Pericom's standard product mark follows our standard part number ordering information, except for those products with a speed letter code. For marking purposes, the speed letter code mark is placed after the package code letter, rather than after the device number as it is ordered.

Although all products are marked immediately after assembly to assure material traceability, Pericom does not usually mark the speed code at that time. After electrical test screening and speed binning has been completed, we then perform an add mark operation which places the speed code letter at the end of the complete part number.

Please refer to the example shown below:
Part Number as ordered: PI74FCT245ATQ
Example of Part Number as marked:

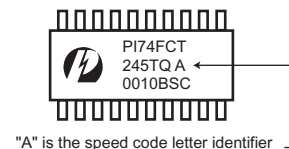

Notes:

- 1) 8-pin DIP, 8-pin SOIC, 8-pin TSSOP, 14-pin SOIC, 16-pin QSOP, SC70, MSOP, and SOT23 packages are not marked with the Pericom logo due to space limitations on the package.