



BULB128D-BT4

HIGH VOLTAGE FAST-SWITCHING NPN POWER TRANSISTOR

Ordering Code	Marking	Shipment
BULB128D-BT4	BULB128DB	Tape & Reel

- STMicroelectronics PREFERRED SALESTYPE
- NPN TRANSISTOR
- HIGH VOLTAGE CAPABILITY
- LOW SPREAD OF DYNAMIC PARAMETERS
- MINIMUM LOT-TO-LOT SPREAD FOR RELIABLE OPERATION
- VERY HIGH SWITCHING SPEED
- INTEGRATED ANTIPARALLEL COLLECTOR-EMITTER DIODE

APPLICATIONS:

- ELECTRONIC BALLASTS FOR FLUORESCENT LIGHTING
- FLYBACK AND FORWARD SINGLE TRANSISTOR LOW POWER CONVERTERS

DESCRIPTION

The device is manufactured using high voltage Multi Epitaxial Planar technology for high switching speeds and medium voltage capability. It uses a Cellular Emitter structure with planar edge termination to enhance switching speeds while maintaining the wide RFSOA.

The device is designed for use in lighting applications and low cost switch-mode power supplies.

ABSOLUTE MAXIMUM RATINGS

Symbo	Parameter	Value	Unit
V_{CES}	Collector-Emitter Voltage ($V_{BE} = 0$)	700	V
V_{CEO}	Collector-Emitter Voltage ($I_B = 0$)	400	V
V_{EBO}	Emitter-Base Voltage ($I_C = 0, I_B = 2 \text{ A}, t_p < 10 \mu\text{s}, T_j < 150^\circ\text{C}$)	$V_{(BR)EBO}$	V
I_C	Collector Current	4	A
I_{CM}	Collector Peak Current ($t_p < 5 \text{ ms}$)	8	A
I_B	Base Current	2	A
I_{BM}	Base Peak Current ($t_p < 5 \text{ ms}$)	4	A
P_{tot}	Total Dissipation at $T_c = 25^\circ\text{C}$	70	W
T_{stg}	Storage Temperature	-65 to 150	$^\circ\text{C}$
T_j	Max. Operating Junction Temperature	150	$^\circ\text{C}$

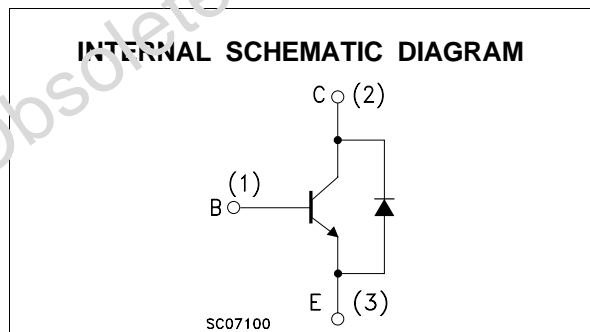
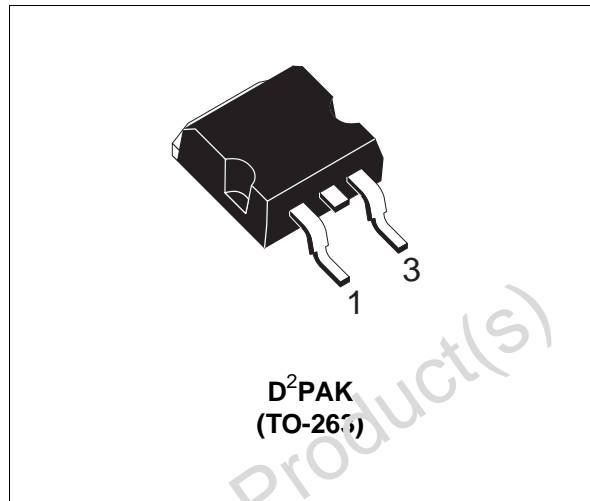

BULB128D-BT4

THERMAL DATA

R _{thj-case}	Thermal Resistance Junction-Case	Max	1.78	°C/W
R _{thj-amb}	Thermal Resistance Junction-Ambient	Max	62.5	°C/W

ELECTRICAL CHARACTERISTICS (T_{case} = 25 °C unless otherwise specified)

Symbol	Parameter	Test Conditions	Min.	Typ.	Max.	Unit
I _{CES}	Collector Cut-off Current (V _{BE} = 0 V)	V _{CE} = 700 V			100	μA
		V _{CE} = 700 V T _C = 125 °C			500	μA
I _{CEO}	Collector Cut-off Current (I _B = 0)	V _{CE} = 400 V			250	μA
V _{(BR)EBO}	Emitter-Base Breakdown Voltage (I _C = 0)	I _E = 10 mA	9		18	V
V _{CEO(sus)*}	Collector-Emitter Sustaining Voltage (I _B = 0)	I _C = 100 mA L = 25 mH	400			V
V _{CE(sat)*}	Collector-Emitter Saturation Voltage	I _C = 0.5 A I _B = 0.1 A			0.7	V
		I _C = 1 A I _B = 0.2 A			1	V
		I _C = 2.5 A I _B = 0.5 A			1.5	V
		I _C = 4 A I _B = 1 A		0.5		V
V _{BE(sat)*}	Base-Emitter Saturation Voltage	I _C = 0.5 A I _B = 0.1 A			1.1	V
		I _C = 1 A I _B = 0.2 A			1.2	V
		I _C = 2.5 A I _B = 0.5 A			1.3	V
h _{FE} *	DC Current Gain	I _C = 10 mA V _{CE} = 5 V	10			
		I _C = 2 A V _{CE} = 5 V	12		32	
V _f	Forward Voltage Drop	I _f = 2 A			2.5	V
t _s t _f	INDUCTIVE LOAD Storage Time Fall Time	V _{CC} = 200 V I _C = 2 A I _{B1} = 0.4 A V _{BE(off)} = -5 V R _{BB} = 0 Ω L = 200 μH (see fig.1)		0.6 0.1		μs μs
		V _{CC} = 250 V I _C = 2 A I _{B1} = 0.4 A I _{B2} = -0.4 A T _p = 300 μs (see fig.2)	2	0.2	2.9	μs μs

* Pulsed: Pulse duration = 300 μs, duty cycle 1.5 %

Safe Operating Areas

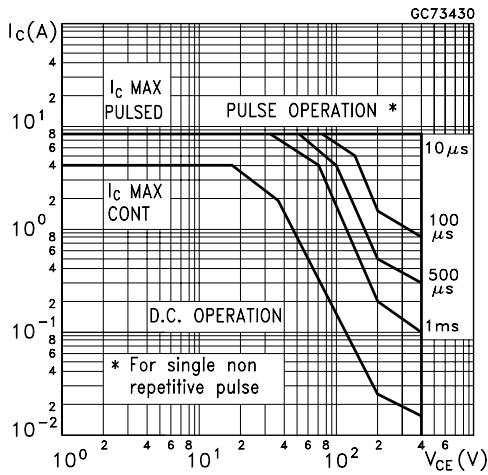

Derating Curve

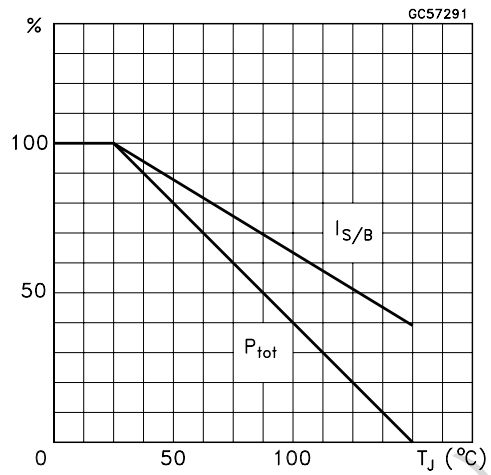

DC Current Gain

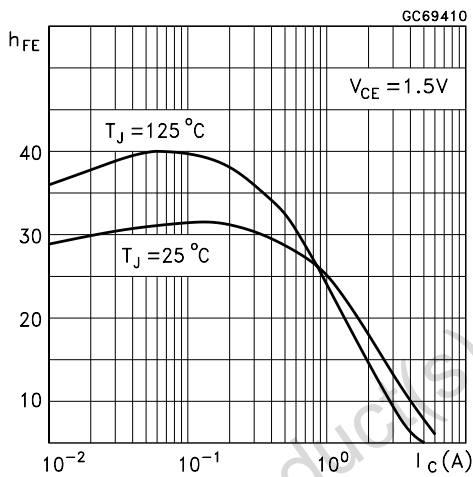

DC Current Gain

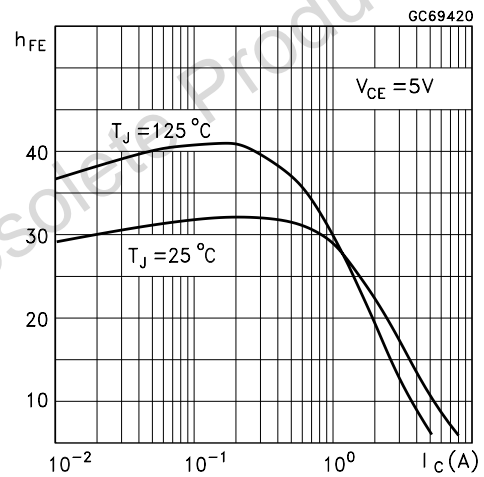

Collector Emitter Saturation Voltage

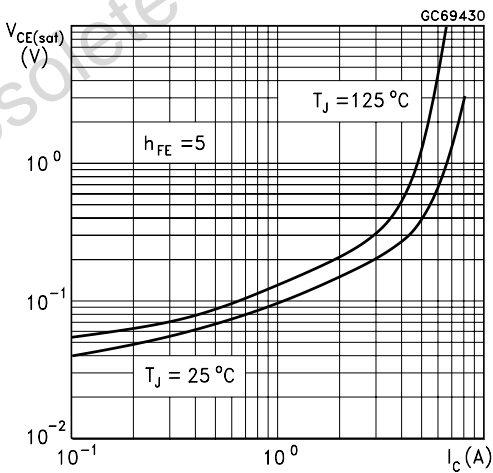

Base Emitter Saturation Voltage

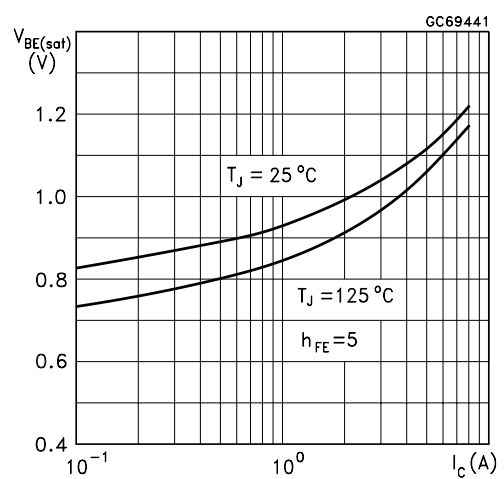

BULB128D-BT4

Inductive Fall Time

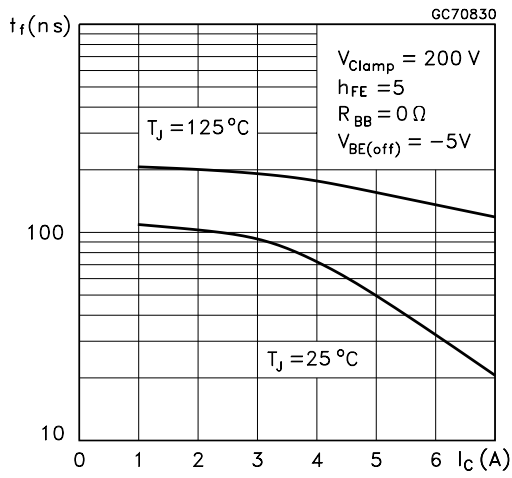

Inductive Storage Time

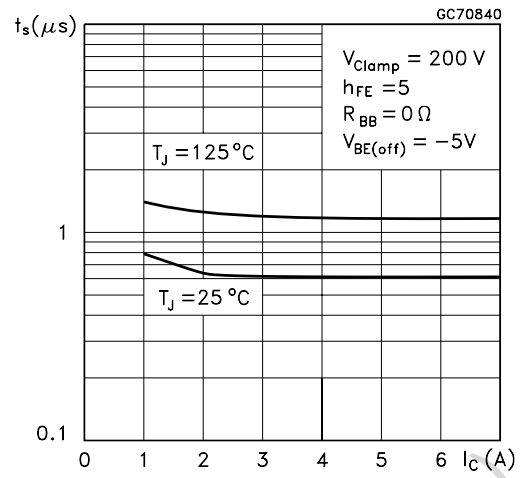

Resistive Load Fall Time

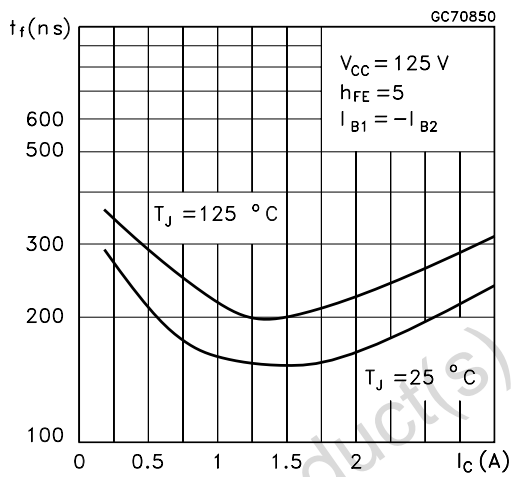

Resistive Load Storage Time

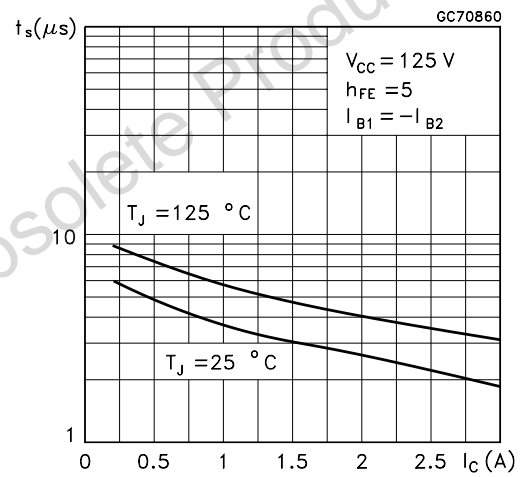

Reverse Biased SOA

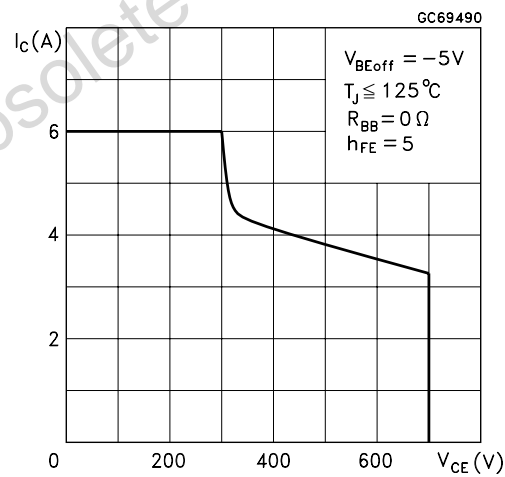

Figure 1: Inductive Load Switching Test Circuits.

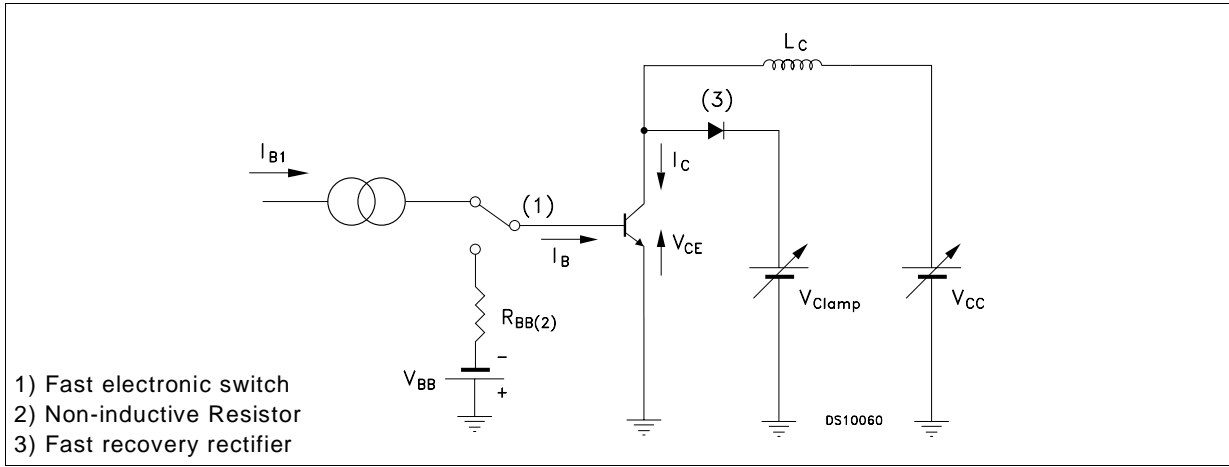
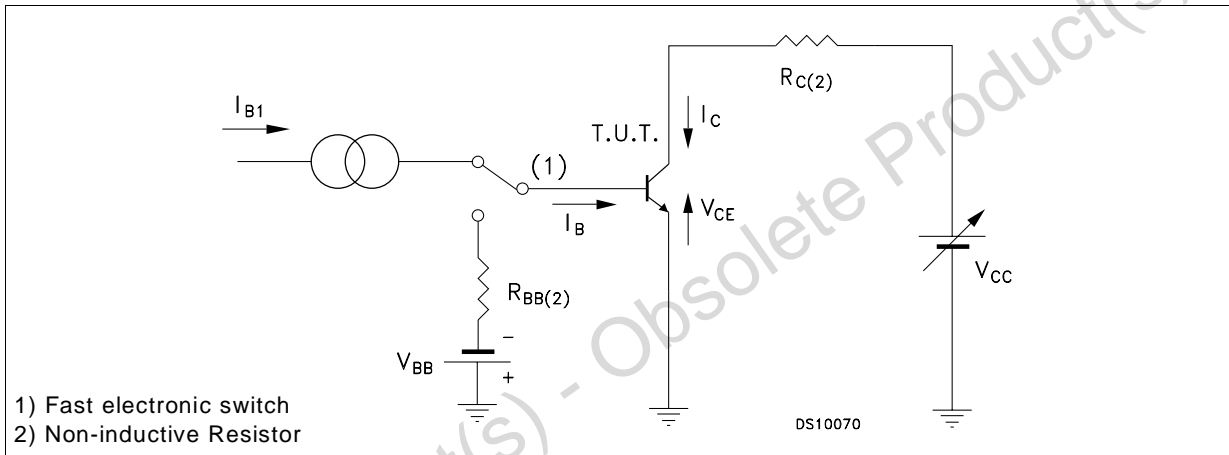

Figure 2: Resistive Load Switching Test Circuits.



Obsolete Product(s) - Obsolete Product(s)

TO-263 (D²PAK) MECHANICAL DATA

DIM.	mm			inch		
	MIN.	TYP.	MAX.	MIN.	TYP.	MAX.
A	4.40		4.60	0.173		0.181
A1	2.49		2.69	0.098		0.106
A2	0.03		0.23	0.001		0.009
B	0.70		0.93	0.027		0.036
B2	1.14		1.70	0.044		0.067
C	0.45		0.60	0.017		0.023
C2	1.23		1.36	0.048		0.053
D	8.95		9.35	0.352		0.368
D1		8.00			0.315	
E	10.00		10.40	0.393		0.409
E1		8.50			0.334	
G	4.88		5.28	0.192		0.208
L	15.00		15.85	0.590		0.624
L2	1.27		1.4	0.050		0.055
L3	1.40		1.75	0.055		0.068
M	2.40		3.2	0.094		0.126
R		0.40			0.016	
V2	0°		8°	0°		8°

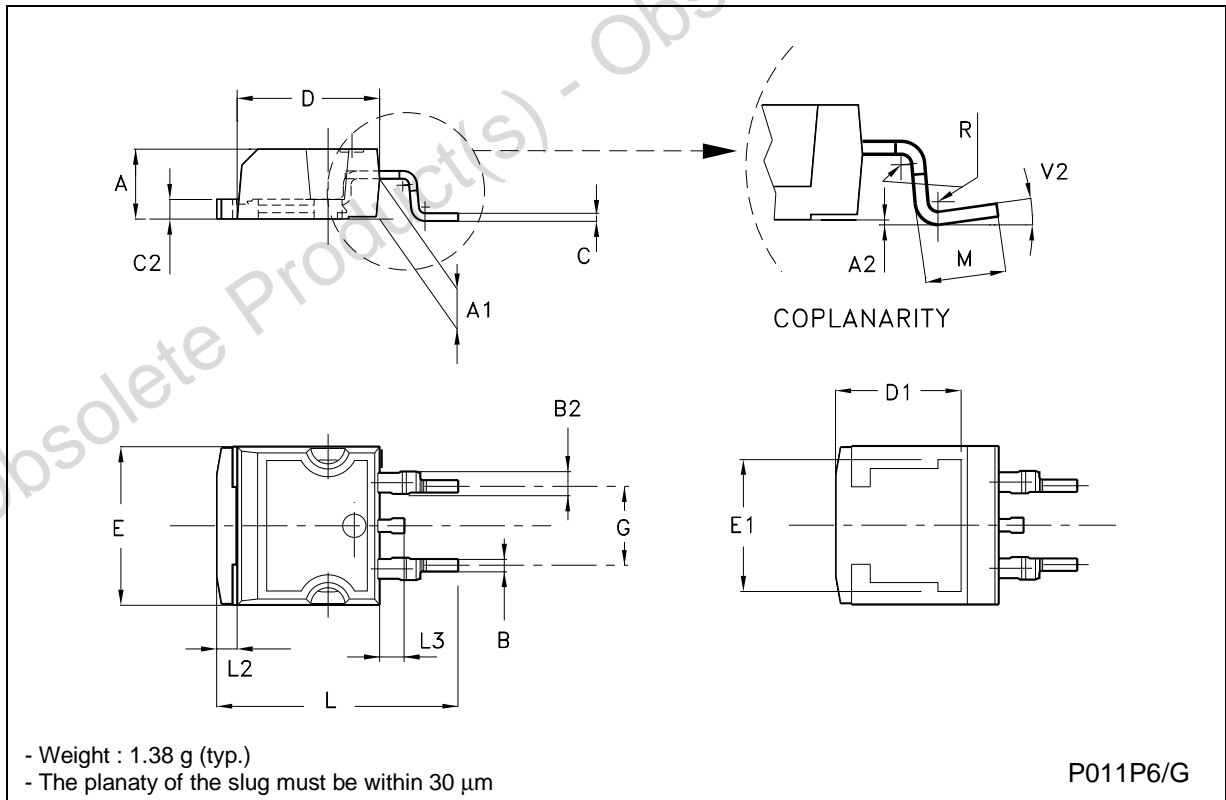

Obsolete Product(s) - Obsolete Product(s)

Information furnished is believed to be accurate and reliable. However, STMicroelectronics assumes no responsibility for the consequences of use of such information nor for any infringement of patents or other rights of third parties which may result from its use. No license is granted by implication or otherwise under any patent or patent rights of STMicroelectronics. Specification mentioned in this publication are subject to change without notice. This publication supersedes and replaces all information previously supplied. STMicroelectronics products are not authorized for use as critical components in life support devices or systems without express written approval of STMicroelectronics.

The ST logo is a trademark of STMicroelectronics.

All other names are the property of their respective owners.

© 2003 STMicroelectronics – All Rights reserved

STMicroelectronics GROUP OF COMPANIES

Australia - Belgium - Brazil - Canada - China - Czech Republic - Finland - France - Germany - Hong Kong - India - Israel - Italy - Japan - Malaysia - Malta - Morocco - Singapore - Spain - Sweden - Switzerland - United Kingdom - United States.

<http://www.st.com>