

High-Speed CMOS Dual 4-Input Multiplexer

Product Features:

- PI74FCT153T/253T/2153T/2253T is pin compatible with bipolar FAST™ Series at a higher speed and lower power consumption
- 25Ω series resistor on all outputs (FCT2XXX only)
- TTL input and output levels
- Low ground bounce outputs (25Ω series only)
- Extremely low static power
- Hysteresis on all inputs
- Industrial operating temperature range: -40°C to +85°C
- Packages available:
 - 16-pin 150 mil wide plastic QSOP (Q16)
 - 16-pin 300 mil wide plastic SOIC (S16)
 - 16-pin 150 mil wide plastic SOIC (W16)

Product Description:

Pericom Semiconductor's PI74FCT series of logic circuits are produced in the Company's advanced 0.8 micron CMOS technology, achieving industry leading speed grades. All PI74FCT2XXX devices have a built-in 25-ohm series resistor on all outputs to reduce noise resulting from reflections, thus eliminating the need for an external terminating resistor.

The PI74FCT153T/253T and PI74FCT2153T/2253T are high-speed dual 4-input multiplexers. The PI74FCT153T/2153T has TTL outputs, while the PI74FCT253T/2253T has 3-state outputs. The output buffers are designed with a power-off disable allowing "live insertion" of boards when used as backplane drivers.

Logic Block Diagram

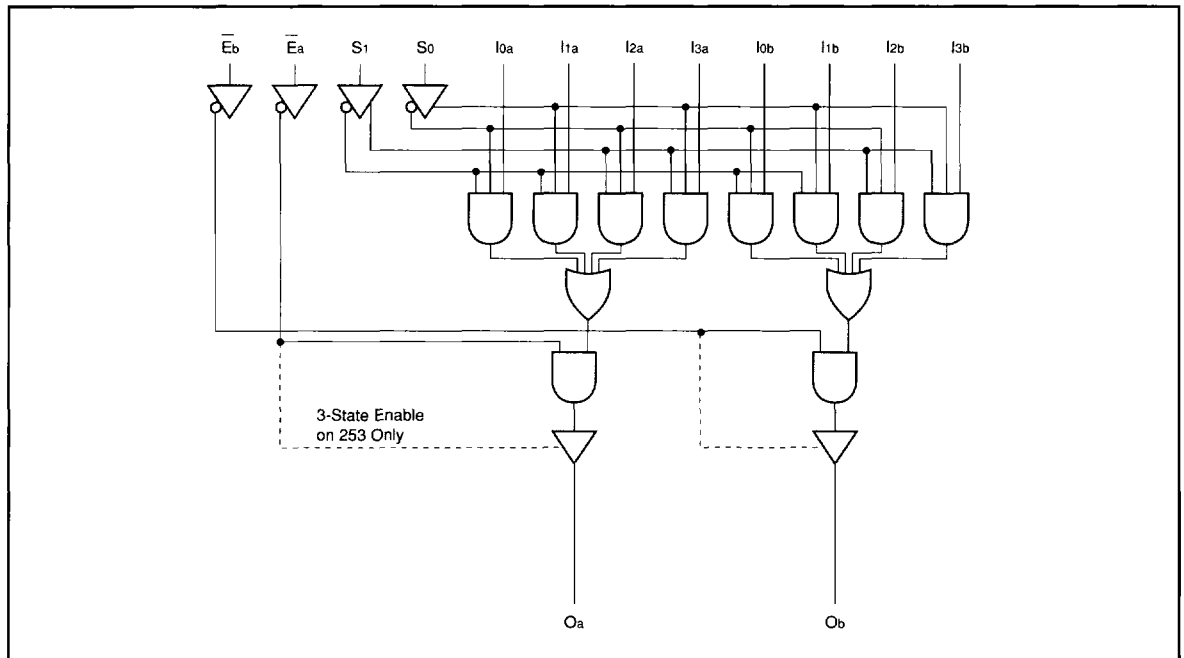

Product Pin Description

Pin Name	Description
I0a-I3a, I0b-I3b	Data Inputs
S0, S1	Select Inputs
$\bar{E}a, \bar{E}b$	Enable Input
Oa, Ob	Data Outputs
GND	Ground
Vcc	Power

Truth Table⁽¹⁾

Inputs				Outputs			
				'153/2153		'253/2253	
$\bar{E}a$	$\bar{E}b$	S1	S0	Oa	Ob	Oa	Ob
H	X	X	X	L	X	Z	X
X	H	X	X	X	L	X	Z
L	L	L	L	I0a	I0b	I0a	I0b
L	L	L	H	I1a	I1b	I1a	I1b
L	L	H	L	I2a	I2b	I2a	I2b
L	L	H	H	I3a	I3b	I3a	I3b

NOTE:

- H = High Voltage Level
 L = Low Voltage Level
 X = Don't Care
 Z = High Impedance

Product Pin Configuration

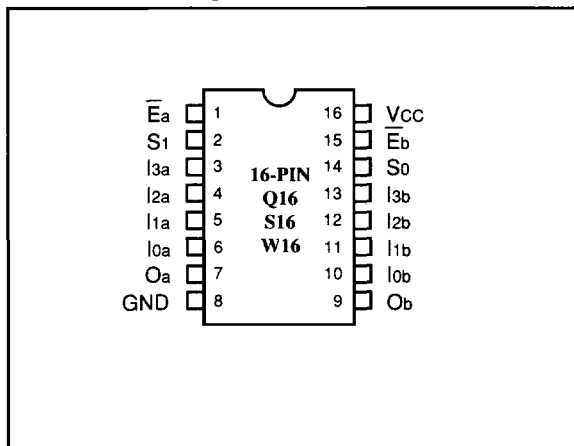

Maximum Ratings

(Above which the useful life may be impaired. For user guidelines, not tested.)

Storage Temperature	-65°C to +150°C
Ambient Temperature with Power Applied	-40°C to +85°C
Supply Voltage to Ground Potential (Inputs & Vcc Only)	-0.5V to +7.0V
Supply Voltage to Ground Potential (Outputs & D/O Only)	-0.5V to +7.0V
DC Input Voltage	-0.5V to +7.0V
DC Output Current	120 mA
Power Dissipation	0.5W

Note:

Stresses greater than those listed under **MAXIMUM RATINGS** may cause permanent damage to the device. This is a stress rating only and functional operation of the device at these or any other conditions above those indicated in the operational sections of this specification is not implied. Exposure to absolute maximum rating conditions for extended periods may affect reliability.

DC Electrical Characteristics (Over the Operating Range, TA = -40°C to +85°C, VCC = 5.0V ± 5%)

Parameters	Description	Test Conditions ⁽¹⁾	Min.	Typ ⁽²⁾	Max.	Units
V _{OH}	Output HIGH Voltage	V _{CC} = Min., V _{IN} = V _{IH} or V _{IL} I _{OH} = -15.0 mA	2.4	3.0		V
V _{OL}	Output LOW Current	V _{CC} = Min., V _{IN} = V _{IH} or V _{IL} I _{OL} = 48 mA		0.3	0.50	V
V _{OL}	Output LOW Current	V _{CC} = Min., V _{IN} = V _{IH} or V _{IL} I _{OL} = 12 mA (25Ω Series)		0.3	0.50	V
V _{IH}	Input HIGH Voltage	Guaranteed Logic HIGH Level	2.0			V
V _{IL}	Input LOW Voltage	Guaranteed Logic LOW Level			0.8	V
I _{IH}	Input HIGH Current	V _{CC} = Max. V _{IN} = V _{CC}			1	μA
I _{IL}	Input LOW Current	V _{CC} = Max. V _{IN} = GND			-1	μA
I _{OZH}	High Impedance	V _{CC} = Max. V _{OUT} = 2.7V			1	μA
I _{OZL}	Output Current	V _{OUT} = 0.5V			-1	μA
V _{IK}	Clamp Diode Voltage	V _{CC} = Min., I _{IN} = -18 mA		-0.7	-1.2	V
I _{OFF}	Power Down Disable	V _{CC} = GND, V _{OUT} = 4.5V	—	—	100	μA
I _{OS}	Short Circuit Current	V _{CC} = Max. ⁽³⁾ , V _{OUT} = GND	-60	-120		mA
V _H	Input Hysteresis			200		mV

Capacitance (TA = 25°C, f = 1 MHz)

Parameters ⁽⁴⁾	Description	Test Conditions	Typ	Max.	Units
C _{IN}	Input Capacitance	V _{IN} = 0V	6	10	pF
C _{OUT}	Output Capacitance	V _{OUT} = 0V	8	12	pF

Notes:

1. For Max. or Min. conditions, use appropriate value specified under Electrical Characteristics for the applicable device type.
2. Typical values are at V_{CC} = 5.0V, +25°C ambient and maximum loading.
3. Not more than one output should be shorted at one time. Duration of the test should not exceed one second.
4. This parameter is determined by device characterization but is not production tested.

Power Supply Characteristics

Parameters	Description	Test Conditions ⁽¹⁾		Min.	Typ ⁽²⁾	Max.	Units
I _{cc}	Quiescent Power Supply Current	V _{CC} = Max.	V _{IN} = GND or V _{CC}		0.1	500	μA
ΔI _{cc}	Supply Current per Input @ TTL HIGH	V _{CC} = Max.	V _{IN} = 3.4V ⁽³⁾		0.5	2.0	mA
I _{ccD}	Supply Current per Input per MHz ⁽⁴⁾	V _{CC} = Max., Outputs Open Other inputs at GND One Bit Toggling 50% Duty Cycle	V _{IN} = V _{CC} V _{IN} = GND		0.15	0.25	mA/ MHz
I _c	Total Power Supply Current ⁽⁶⁾	V _{CC} = Max., Outputs Open f _i = 10 MHz 50% Duty Cycle Other inputs at GND One Bit Toggling	V _{IN} = V _{CC} V _{IN} = GND		3.2	6.5 ⁽⁵⁾	mA
			V _{IN} = 3.4V V _{IN} = GND		3.5	7.5 ⁽⁵⁾	

Notes:

- For conditions shown as Max. or Min., use appropriate value specified under Electrical Characteristics for the applicable device.
- Typical values are at V_{CC} = 5.0V, +25°C ambient.
- Per TTL driven input (V_{IN} = 3.4V); all other inputs at V_{CC} or GND.
- This parameter is not directly testable, but is derived for use in Total Power Supply Calculations.
- Values for these conditions are examples of the I_{cc} formula. These limits are guaranteed but not tested.
- I_c = I_{QUIESCENT} + I_{INPUTS} + I_{DYNAMIC}

$$I_c = I_{cc} + \Delta I_{cc} D_H N_T + I_{ccD} (f_{CP}/2 + f_i N_i)$$

I_{cc} = Quiescent Current
ΔI_{cc} = Power Supply Current for a TTL High Input (V_{IN} = 3.4V)
D_H = Duty Cycle for TTL Inputs High
N_T = Number of TTL Inputs at D_H
I_{ccD} = Dynamic Current Caused by an Input Transition Pair (HLH or LHL)
f_{CP} = Clock Frequency for Register Devices (Zero for Non-Register Devices)
f_i = Input Frequency
N_i = Number of Inputs at f_i
All currents are in milliamps and all frequencies are in megahertz.

PI74FCT153/2153T Switching Characteristics over Operating Range

Parameters	Description	Conditions ⁽¹⁾	153T/2153T		153AT/2153AT		153CT/2153CT		Unit
			Com.		Com.		Com.		
			Min	Max	Min	Max	Min	Max	
t _{PLH} t _{PHL}	Propagation Delay S _n to O	C _L = 50 pF R _L = 500Ω	1.5	9.0	1.5	6.6	1.5	5.6	ns
t _{PLH} t _{PHL}	Propagation Delay I _n to O		1.5	7.0	1.5	5.2	1.5	4.5	ns
t _{PLH} t _{PHL}	Propagation Delay E̅ to O		1.5	7.0	1.5	5.2	1.5	4.8	ns

PI74FCT253/2253T Switching Characteristics over Operating Range

Parameters	Description	Conditions ⁽¹⁾	253T/2253T		253AT/2253AT		253CT/2253CT		Unit
			Com.		Com.		Com.		
			Min	Max	Min	Max	Min	Max	
t _{PLH} t _{PHL}	Propagation Delay S _n to O	C _L = 50 pF R _L = 500Ω	1.5	9.0	1.5	6.6	1.5	5.6	ns
t _{PLH} t _{PHL}	Propagation Delay I _n to O		1.5	7.0	1.5	5.2	1.5	4.5	ns
t _{PZH} t _{PZL}	Output Enable Time E̅ to O		1.5	9.0	1.5	6.0	1.5	5.0	ns
t _{PHZ} t _{PLZ}	Output Disable Time ⁽³⁾ E̅ to O		1.5	7.0	1.5	6.0	1.5	5.0	ns

Notes:

1. See test circuit and wave forms.
2. Minimum limits are guaranteed but not tested on Propagation Delays.
3. This parameter guaranteed but not production tested.