

876

T-46-07-08



DM74AS876 Dual 4-Bit D-Type Edge-Triggered Flip-Flop with TRI-STATE® Outputs

General Description

These inverting dual 4-bit registers feature totem-pole TRI-STATE outputs designed specifically for driving highly-capacitive or relatively low-impedance loads. The high-impedance state and increased high-logic-level drive provide these registers with the capability of being connected directly to and driving the bus lines in a bus-organized system without need for interface or pull-up components. They are particularly attractive for implementing buffer registers, I/O ports, bidirectional bus drivers, and working registers.

The eight flip-flops of the AS876 are edge-triggered inverting D-type flip-flops. On the positive transition of the clock, the Q outputs will be set to the complement of the logic states that were set up at the D inputs.

A buffered output control input can be used to place the eight outputs in either a normal logic state (high or low logic levels) or a high-impedance state. In the high-impedance state the outputs neither load nor drive the bus lines significantly.

The output control does not affect the internal operation of the flip-flops. That is, the old data can be retained or new data can be entered even while the outputs are off.

The pinout is arranged to ease printed circuit board layout. All data inputs are on one side of the package, while all outputs are on the other side.

Features

- Switching specifications at 50 pF
- Switching specifications guaranteed over full temperature and V_{CC} range
- Advanced oxide-isolated, ion-implanted Schottky TTL process
- TRI-STATE buffer-type outputs drive bus lines directly
- Space saving 300 mil wide package
- Bus structured pinout

Connection Diagram

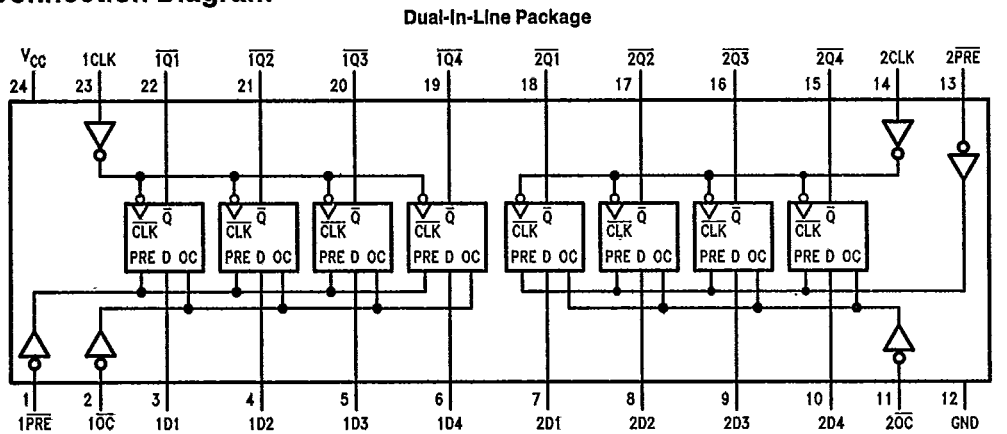

TL/F/6332-1

Order Number DM74AS876NT
See NS Package Number N24C*

*Contact your local NSC representative about surface mount (M) package availability.

876

T-46-07-08

Absolute Maximum Ratings

Supply Voltage	7V
Input Voltage	7V
Voltage Applied to Disabled Output	5.5V
Operating Free Air Temperature Range	0°C to +70°C
Storage Temperature Range	-65°C to +150°C
Typical θ_{JA} N Package	47.0°C/W

Note: The "Absolute Maximum Ratings" are those values beyond which the safety of the device cannot be guaranteed. The device should not be operated at these limits. The parametric values defined in the "Electrical Characteristics" table are not guaranteed at the absolute maximum ratings. The "Recommended Operating Conditions" table will define the conditions for actual device operation.

Recommended Operating Conditions

Symbol	Parameter	Min	Nom	Max	Units
V _{CC}	Supply Voltage	4.5	5	5.5	V
V _{IH}	High Level Input Voltage	2			V
V _{IL}	Low Level Input Voltage			0.8	V
I _{OH}	High Level Output Current			-15	mA
I _{OL}	Low Level Output Current			48	mA
f _{CLK}	Clock Frequency	0		80	MHz
t _w (CLK)	Width of Clock Pulse	High	3		ns
		Low	6		
t _w (PRE)	Width of Preset Pulse	Low	2		ns
t _{SU}	Data	Data	4 ↑		ns
		Preset Inactive	5 ↑		
t _H	Data Hold Time		1 ↑		ns
T _A	Free Air Operating Temperature	0		70	°C

The (↑) arrow indicates the positive edge of the Clock is used for reference.

Electrical Characteristics

over recommended operating free air temperature range. All typical values are measured at V_{CC} = 5V, T_A = 25°C.

Symbol	Parameter	Conditions	Min	Typ	Max	Units	
V _{IK}	Input Clamp Voltage	V _{CC} = 4.5V, I _I = -18 mA			-1.2	V	
V _{OH}	High Level Output Voltage	V _{CC} = 4.5V, V _{IL} = V _{IL} Max, I _{OH} = Max	2.4	3.3		V	
		I _{OH} = -2 mA, V _{CC} = 4.5V to 5.5V	V _{CC} - 2				
V _{OL}	Low Level Output Voltage	V _{CC} = 4.5V, V _{IH} = 2V, I _{OL} = Max		0.35	0.5	V	
I _I	Input Current at Max Input Voltage	V _{CC} = 5.5V, V _{IH} = 7V			0.1	mA	
I _{IH}	High Level Input Current	V _{CC} = 5.5V, V _{IH} = 2.7V			20	μA	
I _{IL}	Low Level Input Current	V _{CC} = 5.5V, V _{IL} = 0.4V			-0.5	mA	
I _O (Note 1)	Output Drive Current	V _{CC} = 5.5V, V _O = 2.25V	-30		-112	mA	
I _{OZH}	Off-State Output Current, High Level Voltage Applied	V _{CC} = 5.5V, V _{IH} = 2V, V _O = 2.7V,			50	μA	
I _{OZL}	Off-State Output Current, Low Level Voltage Applied	V _{CC} = 5.5V, V _{IH} = 2V, V _O = 0.4V			-50	μA	
I _{CC}	Supply Current	V _{CC} = 5.5V Outputs Open	Outputs High	88	142	mA	
			Outputs Low		94		150
			Outputs Disabled		100		160

Note 1: The output conditions have been chosen to produce a current that closely approximates one half of the true short circuit current, I_{OS}.



T-46-07-08

876

Switching Characteristics over recommended operating free air temperature range (Note 1)

Symbol	Parameter	Conditions	From	To	Min	Max	Units
f _{MAX}	Maximum Clock Frequency	V _{CC} = 4.5V to 5.5V R _L = 500Ω C _L = 50 pF			80		MHz
t _{PLH}	Propagation Delay Time Low to High Level Output		Clock	Any \bar{Q}	3	8.5	ns
t _{PHL}	Propagation Delay Time High to Low Level Output		Clock	Any \bar{Q}	4	10.5	ns
t _{PZH}	Output Enable Time to High Level Output		Output Control	Any \bar{Q}	2	7	ns
t _{PZL}	Output Enable Time to Low Level Output		Output Control	Any \bar{Q}	3	10.5	ns
t _{PHZ}	Output Disable Time from High Level Output		Output Control	Any \bar{Q}	2	6	ns
t _{PLZ}	Output Disable Time from Low Level Output		Output Control	Any \bar{Q}	2	6	ns
t _{PHL}	Propagation Delay Time High to Low Level Output		Preset	Any \bar{Q}	4	10	ns

Note 1: See Section 1 for test waveforms and output load.

Logic Diagram

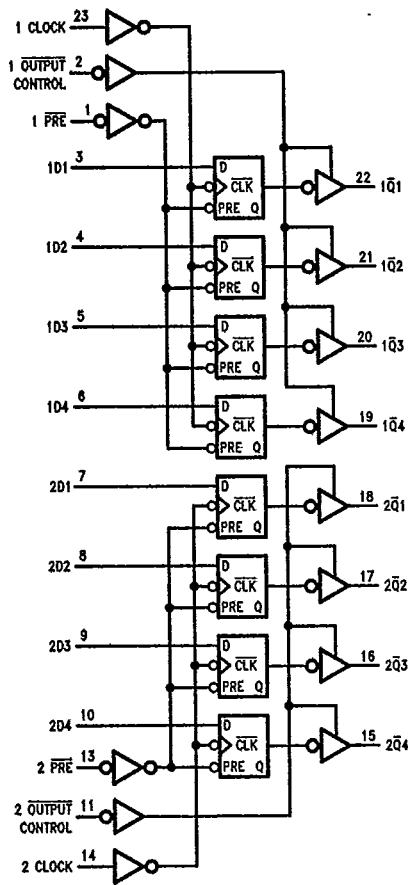

TL/F/6332-2

Function Table

PRE	Inputs			Output \bar{Q}
	D	CLK	\bar{OC}	
X	X	X	H	Z
L	X	X	L	L
H	H	↑	L	L
H	L	↑	L	H
H	X	L	L	\bar{Q}_0

L = Low State, H = High State, X = Don't Care
 ↑ = Positive Edge Transition
 Z = High Impedance State
 \bar{Q}_0 = Previous Condition of \bar{Q}