

74LS245 Transceiver

Octal Transceiver (3-State)
Product Specification

Logic Products

FEATURES

- Octal bidirectional bus interface
- 3-State buffer outputs
- PNP inputs for reduced loading
- Hysteresis on all Data inputs

DESCRIPTION

The 'LS245 is an octal transceiver featuring non-inverting 3-State bus compatible outputs in both send and receive directions. The outputs are all capable of sinking 24mA and sourcing up to 15mA, producing very good capacitive drive characteristics. The device features a Chip Enable (CE) input for easy cascading and a Send/Receive (S/R) input for direction control. All data inputs have hysteresis built in to minimize AC noise effects.

TYPE	TYPICAL PROPAGATION DELAY	TYPICAL SUPPLY CURRENT (TOTAL)
74LS245	8ns	58mA

ORDERING CODE

PACKAGES	COMMERCIAL RANGE $V_{CC} = 5V \pm 5\%$; $T_A = 0^\circ C$ to $+70^\circ C$
Plastic DIP	N74LS245N
Plastic SOL-20	N74LS245D

NOTE:

For information regarding devices processed to Military Specifications, see the Signetics Military Products Data Manual.

INPUT AND OUTPUT LOADING AND FAN-OUT TABLE

PINS	DESCRIPTION	74LS
All	Inputs	1LSul
All	Outputs	30LSul

NOTE:

Where a 74LS unit load (LSul) is $20\mu A$ I_{IH} and $-0.4mA$ I_{IL} .

PIN CONFIGURATION

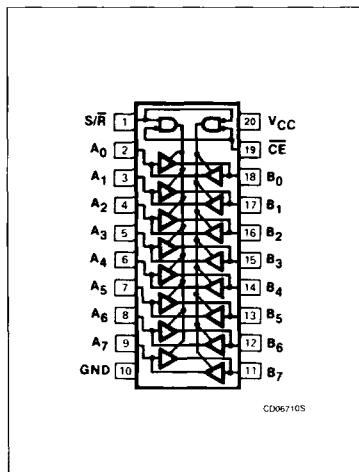

LOGIC SYMBOL

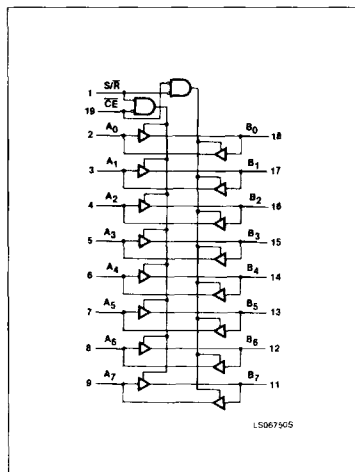

LOGIC SYMBOL (IEEE/IEC)

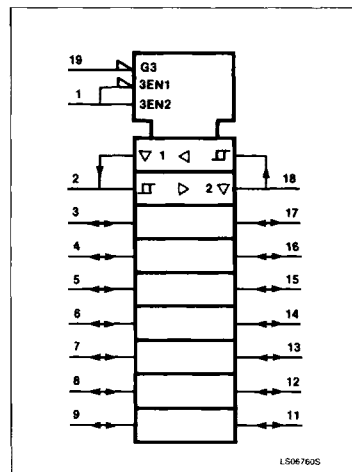

Transceiver

74LS245

FUNCTION TABLE

INPUTS		INPUTS/OUTPUTS	
CE	S/ \bar{R}	A _n	B _n
L	L	A = B	INPUTS
L	H	INPUT	B = A
H	X	(Z)	(Z)

H = HIGH voltage level

L = LOW voltage level

X = Don't care

(Z) = HIGH impedance "off" state

ABSOLUTE MAXIMUM RATINGS (Over operating free-air temperature range unless otherwise noted.)

PARAMETER		74LS	UNIT
V _{CC}	Supply voltage	7.0	V
V _{IN}	Input voltage	-0.5 to +7.0	V
I _{IN}	Input current	-30 to +1	mA
V _{OUT}	Voltage applied to output in HIGH output state	-0.5 to +V _{CC}	V
T _A	Operating free-air temperature range	0 to 70	°C

NOTE

V_{IN} limited to 5.5V on A and B inputs only.

RECOMMENDED OPERATING CONDITIONS

PARAMETER		74LS			UNIT
		Min	Nom	Max	
V _{CC}	Supply voltage	4.75	5.0	5.25	V
V _{IH}	HIGH-level input voltage	2.0			V
V _{IL}	LOW-level input voltage			+0.8	V
I _{IK}	Input clamp current			-18	mA
I _{OH}	HIGH-level output current			-15	mA
I _{OL}	LOW-level output current			24	mA
T _A	Operating free-air temperature	0		70	°C

Transceiver

74LS245

DC ELECTRICAL CHARACTERISTICS (Over recommended operating free-air temperature range unless otherwise noted.)

PARAMETER	TEST CONDITIONS ¹	74LS245			UNIT
		Min	Typ ²	Max	
ΔV_T Hysteresis ($V_{T+} - V_{T-}$)	$V_{CC} = \text{MIN}$	0.2	0.4		V
V_{OH} HIGH-level output voltage	$V_{CC} = \text{MIN}$, $V_{IH} = \text{MIN}$, $V_L = \text{MAX}$	$I_{OH} = \text{MAX}$	2.0		V
		$I_{OH} = -3\text{mA}$	2.4	3.4	V
V_{OL} LOW-level output voltage	$V_{CC} = \text{MIN}$, $V_{IH} = \text{MIN}$, $V_L = \text{MAX}$	$I_{OL} = \text{MAX}$		0.5	V
		$I_{OL} = 12\text{mA}$ (74LS)		0.4	V
V_{IK} Input clamp voltage	$V_{CC} = \text{MIN}$, $I_I = I_{IK}$			-1.5	V
I_{OZH} Off-state output current, HIGH-level voltage applied	$V_{CC} = \text{MAX}$, $V_O = 2.7\text{V}$, $\overline{CE} = 2.0\text{V}$			20	μA
I_{OZL} Off-state output current, LOW-level voltage applied	$V_{CC} = \text{MAX}$, $V_O = 0.4\text{V}$, $\overline{CE} = 2.0\text{V}$			-200	μA
I_I Input current at maximum Input voltage	$V_{CC} = \text{MAX}$	$V_I = 5.5\text{V}$ A, B inputs		0.1	mA
		$V_I = 7.0\text{V}$ S/R, \overline{CE} inputs		0.1	mA
I_{IH} HIGH-level input current	$V_{CC} = \text{MAX}$, $V_I = 2.7\text{V}$			20	μA
I_{IL} LOW-level input current	$V_{CC} = \text{MAX}$, $V_I = 0.4\text{V}$			-0.2	mA
I_{OS} Short-circuit output current ³	$V_{CC} = \text{MAX}$	-40		-130	mA
I_{CC} Supply current ⁴ (total)	$V_{CC} = \text{MAX}$	I_{CCH} Outputs HIGH	48	70	mA
		I_{CCL} Outputs LOW	62	90	mA
		I_{CCZ} Outputs OFF	64	95	mA

NOTES:

- For conditions shown as MIN or MAX, use the appropriate value specified under recommended operating conditions for the applicable type.
- All typical values are at $V_{CC} = 5\text{V}$, $T_A = 25^\circ\text{C}$.
- I_{OS} is tested with $V_{OUT} = +0.5\text{V}$ and $V_{CC} = V_{CC} \text{ MAX} + 0.5\text{V}$. Not more than one output should be shorted at a time and duration of the short circuit should not exceed one second.
- Measure I_{CC} with outputs open.

AC ELECTRICAL CHARACTERISTICS $T_A = 25^\circ\text{C}$, $V_{CC} = 5.0\text{V}$

PARAMETER	TEST CONDITIONS	74LS		UNIT
		$C_L = 4\text{pF}$, $R_L = 667\Omega$		
		Min	Max	
t_{PLH} Propagation delay	Waveform 1		12	ns
t_{PHL} Propagation delay	Waveform 1		12	ns
t_{PZH} Enable to HIGH	Waveform 2		40	ns
t_{PZL} Enable to LOW	Waveform 3		40	ns
t_{PHZ} Disable from HIGH	Waveform 2, $C_L = 5\text{pF}$		25	ns
t_{PLZ} Disable from LOW	Waveform 3, $C_L = 5\text{pF}$		25	ns

Transceiver

74LS245

AC WAVEFORMS

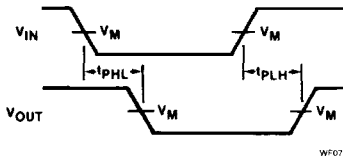

Waveform 1. Waveform For Non-Inverting Outputs

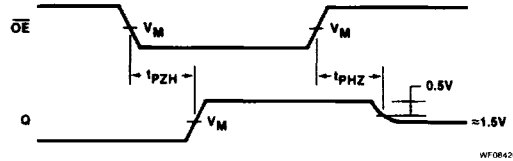

Waveform 2. 3-State Enable Time To High Level And Disable Time From High Level

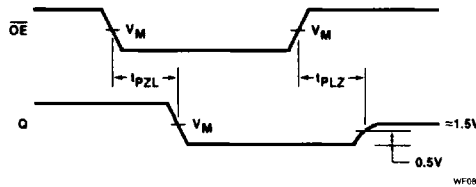

For all waveforms, $V_M = 1.3V$ for 74LS; $V_M = 1.5V$ for all other TTL families.

Waveform 3. 3-State Enable Time To Low Level And Disable Time From Low Level

TEST CIRCUITS AND WAVEFORMS

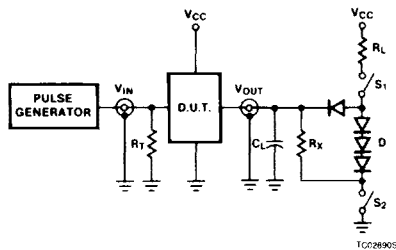

Test Circuit For 3-State Outputs

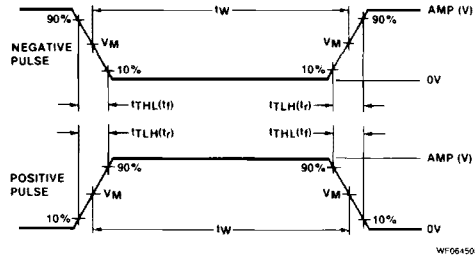

$V_M = 1.3V$ for 74LS; $V_M = 1.5V$ for all other TTL families.

Input Pulse Definition

SWITCH POSITION

TEST	SWITCH 1	SWITCH 2
t_{PZH}	Open	Closed
t_{PZL}	Closed	Open
t_{PHZ}	Closed	Closed
t_{PLZ}	Closed	Closed

DEFINITIONS

R_L = Load resistor to V_{CC} ; see AC CHARACTERISTICS for value.

C_L = Load capacitance includes jig and probe capacitance; see AC CHARACTERISTICS for value.

R_T = Termination resistance should be equal to Z_{OUT} of Pulse Generators.

D = Diodes are 1N916, 1N3064, or equivalent.

$R_X = 1k\Omega$ for 74, 74LS, $R_X = 5k\Omega$ for 74LS.

t_{TLH} , t_{THL} Values should be less than or equal to the table entries.

FAMILY	INPUT PULSE REQUIREMENTS				
	Amplitude	Rep. Rate	Pulse Width	t_{TLH}	t_{THL}
74	3.0V	1MHz	500ns	7ns	7ns
74LS	3.0V	1MHz	500ns	15ns	6ns
74S	3.0V	1MHz	500ns	2.5ns	2.5ns