

20A

T-43-15-00



DM54ALS20A/DM74ALS20A Dual 4-Input NAND Gate

General Description

This device contains two independent gates, each of which performs the logic NAND function.

Features

- Switching specifications at 50 pF
- Switching specifications guaranteed over full temperature and V_{CC} range

- Advanced oxide-isolated, ion-implanted Schottky TTL process
- Functionally and pin for pin compatible with Schottky and low power Schottky TTL counterpart
- Improved AC performance over Schottky and low power Schottky counterparts

Connection Diagram

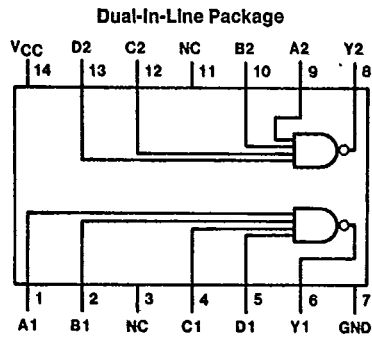

Order Number DM54ALS20AJ, DM74ALS20AM or DM74ALS20AN
See NS Package Number J14A, M14A or N14A

TL/F/8184-1

Function Table

$$Y = \overline{ABCD}$$

Inputs				Output
A	B	C	D	Y
X	X	X	L	H
X	X	L	X	H
X	L	X	X	H
L	X	X	X	H
H	H	H	H	L

H = High Logic Level
L = Low Logic Level
X = Either Low or High Logic Level

T-43-15

Absolute Maximum Ratings

If Military/Aerospace specified devices are required, please contact the National Semiconductor Sales Office/Distributors for availability and specifications.

Supply Voltage	7V
Input Voltage	7V
Operating Free Air Temperature Range	
DM54ALS	-55°C to +125°C
DM74ALS	0°C to +70°C
Storage Temperature Range	-65°C to +150°C
Typical θ_{JA}	
N Package	86.5°C/W
M Package	116.0°C/W

Note: The "Absolute Maximum Ratings" are those values beyond which the safety of the device cannot be guaranteed. The device should not be operated at these limits. The parametric values defined in the "Electrical Characteristics" table are not guaranteed at the absolute maximum ratings. The "Recommended Operating Conditions" table will define the conditions for actual device operation.

Recommended Operating Conditions

Symbol	Parameter	DM54ALS20A			DM74ALS20A			Units
		Min	Nom	Max	Min	Nom	Max	
V _{CC}	Supply Voltage	4.5	5	5.5	4.5	5	5.5	V
V _{IH}	High Level Input Voltage	2			2			V
V _{IL}	Low Level Input Voltage			0.7			0.8	V
I _{OH}	High Level Output Current			-0.4			-0.4	mA
I _{OL}	Low Level Output Current			4			8	mA
T _A	Free Air Operating Temperature	-55		125	0		70	°C

Electrical Characteristics

over recommended operating free air temperature range. All typical values are measured at V_{CC} = 5V, T_A = 25°C.

Symbol	Parameter	Conditions	Min	Typ	Max	Units
V _{IK}	Input Clamp Voltage	V _{CC} = 4.5V, I _I = -18 mA			-1.5	V
V _{OH}	High Level Output Voltage	I _{OH} = -0.4 mA V _{CC} = 4.5V to 5.5V	V _{CC} - 2			V
V _{OL}	Low Level Output Voltage	V _{CC} = 4.5V 54/74ALS I _{OL} = 4 mA		0.25	0.4	V
				0.35	0.5	V
I _I	Input Current @ Max Input Voltage	V _{CC} = 5.5V, V _{IH} = 7V			0.1	mA
I _{IH}	High Level Input Current	V _{CC} = 5.5V, V _{IH} = 2.7V			20	μA
I _{IL}	Low Level Input Current	V _{CC} = 5.5V, V _{IL} = 0.4V			-0.1	mA
I _O	Output Drive Current	V _{CC} = 5.5V V _O = 2.25V	-30		-112	mA
I _{CC}	Supply Current	V _{CC} = 5.5V	Outputs High	0.22	0.4	mA
			Outputs Low	0.81	1.5	mA

Switching Characteristics

over recommended operating free air temperature range (Note 1).

Symbol	Parameter	Conditions	DM54ALS20A		DM74ALS20A		Units
			Min	Max	Min	Max	
t _{PLH}	Propagation Delay Time Low to High Level Output	V _{CC} = 4.5V to 5.5V R _L = 500Ω C _L = 50 pF	1	12.5	3	11	ns
t _{PHL}	Propagation Delay Time High to Low Level Output		1	11.0	3	10	ns

Note 1: See Section 1 for test waveforms and output load.

