

DATA SHEET

74LV153

Dual 4-input multiplexer

Product specification
Supersedes data of 1997 Feb 12
IC24 Data Handbook

1998 Apr 28

Dual 4-input multiplexer

74LV153

FEATURES

- Optimized for low voltage applications: 1.0 to 3.6 V
- Accepts TTL input levels between $V_{CC} = 2.7$ V and $V_{CC} = 3.6$ V
- Typical V_{OLP} (output ground bounce) < 0.8 V at $V_{CC} = 3.3$ V, $T_{amb} = 25^{\circ}\text{C}$
- Typical V_{OHV} (output V_{OH} undershoot) > 2 V at $V_{CC} = 3.3$ V, $T_{amb} = 25^{\circ}\text{C}$
- Non-inverting outputs
- Separate enable for each output
- Common select inputs
- Permits multiplexing from n lines to 1 line
- Enable line provided for cascading (n lines to 1 line)
- Output capability: standard
- I_{CC} category: MSI

DESCRIPTION

The 74LV153 is a low-voltage CMOS device that is pin and function compatible with 74HC/HCT153.

The 74LV153 is a dual 4-input multiplexer which selects 2 bits of data from up to four sources selected by common data select inputs (S_0, S_1). The two 4-input multiplexer circuits have individual active LOW output enable inputs ($1\bar{E}, 2\bar{E}$) which can be used to strobe the outputs independently. The outputs (1Y, 2Y) are forced LOW when the corresponding output enable inputs are HIGH. The 74LV153 is the logic implementation of a 2-pole, 4-position switch, where the position of the switch, is determined by the logic levels applied to S_0 and S_1 . The logic equations for the outputs are:

$$1Y = 1\bar{E} \cdot (1I_0 \cdot \bar{S}_1 \cdot \bar{S}_0 + 1I_1 \cdot \bar{S}_1 \cdot S_0 + 1I_2 \cdot S_1 \cdot \bar{S}_0 + 1I_3 \cdot S_1 \cdot S_0)$$

$$2Y = 2\bar{E} \cdot (2I_0 \cdot \bar{S}_1 \cdot \bar{S}_0 + 2I_1 \cdot \bar{S}_1 \cdot S_0 + 2I_2 \cdot S_1 \cdot \bar{S}_0 + 2I_3 \cdot S_1 \cdot S_0)$$

The 74LV153 can be used to move data to a common output bus from a group of registers. The state of the select inputs would determine the particular register from which the data came. An alternative application is a function generator. The device can generate two functions or three variables. This is useful for implementing highly irregular random logic.

QUICK REFERENCE DATA

GND = 0 V; $T_{amb} = 25^{\circ}\text{C}$; $t_r = t_f \leq 2.5$ ns

SYMBOL	PARAMETER	CONDITIONS	TYPICAL	UNIT
t_{PHL}/t_{PLH}	Propagation delay 1 $I_n, 2I_n$ to nY Sn to nY n \bar{E} to nY	$C_L = 15$ pF; $V_{CC} = 3.3$ V	14 14 10	ns
C_I	Input capacitance		3.5	pF
C_{PD}	Power dissipation capacitance per gate	$V_I = \text{GND to } V_{CC}^1$	30	pF

NOTE:

1. C_{PD} is used to determine the dynamic power dissipation (P_D in μW)
 $P_D = C_{PD} \times V_{CC}^2 \times f_i + \sum (C_L \times V_{CC}^2 \times f_o)$ where:
 f_i = input frequency in MHz; C_L = output load capacitance in pF;
 f_o = output frequency in MHz; V_{CC} = supply voltage in V;
 $\sum (C_L \times V_{CC}^2 \times f_o)$ = sum of the outputs.

ORDERING INFORMATION

PACKAGES	TEMPERATURE RANGE	OUTSIDE NORTH AMERICA	NORTH AMERICA	PKG. DWG. #
16-Pin Plastic DIL	$-40^{\circ}\text{C to } +125^{\circ}\text{C}$	74LV153 N	74LV153 N	SOT38-4
16-Pin Plastic SO	$-40^{\circ}\text{C to } +125^{\circ}\text{C}$	74LV153 D	74LV153 D	SOT109-1
16-Pin Plastic SSOP Type II	$-40^{\circ}\text{C to } +125^{\circ}\text{C}$	74LV153 DB	74LV153 DB	SOT338-1
16-Pin Plastic TSSOP Type I	$-40^{\circ}\text{C to } +125^{\circ}\text{C}$	74LV153 PW	74LV153PW DH	SOT403-1

Dual 4-input multiplexer

74LV153

PIN CONFIGURATION

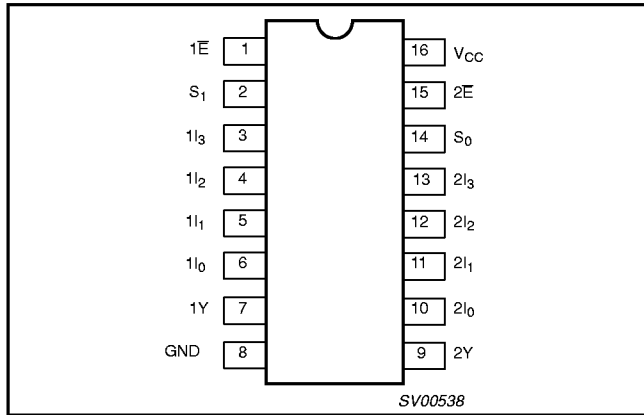

PIN DESCRIPTION

PIN NUMBER	SYMBOL	FUNCTION
1, 15	1E, 2E	Output enable inputs (active LOW)
14, 2	S ₀ , S ₁	Common data select inputs
6, 5, 4, 3	1I ₀ to 1I ₃	Data inputs from source 1
7	1Y	Multiplexer output from source 1
8	GND	Ground (0 V)
9	2Y	Multiplexer output from source 2
10, 11, 12, 13	2I ₀ to 2I ₃	Data inputs from source 2
16	V _{CC}	Positive supply voltage

LOGIC SYMBOL

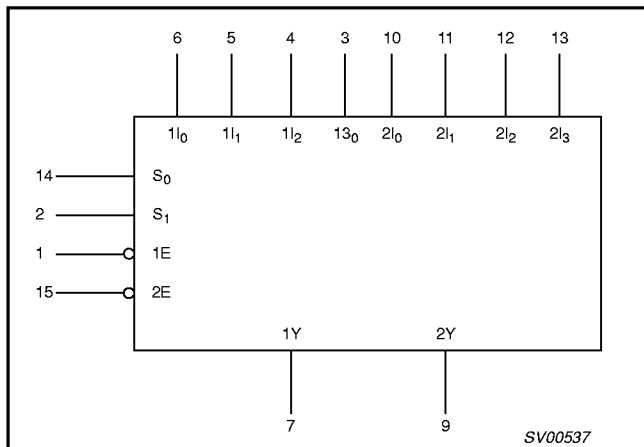

LOGIC SYMBOL (IEEE/IEC)

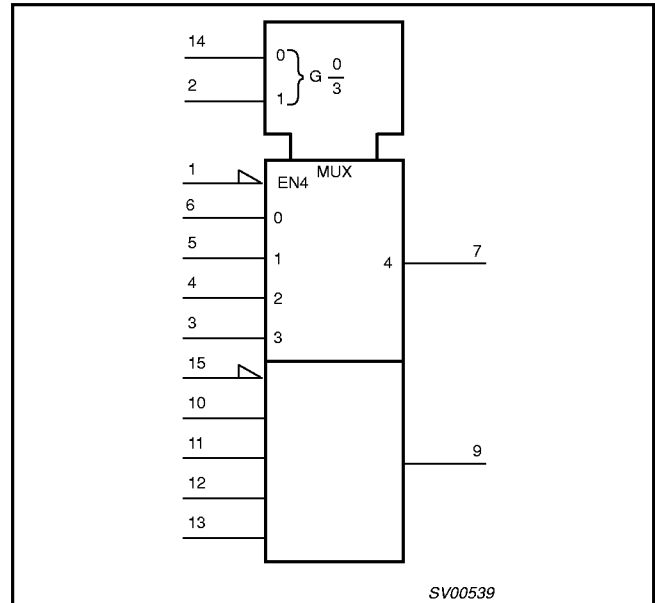

FUNCTIONAL DIAGRAM

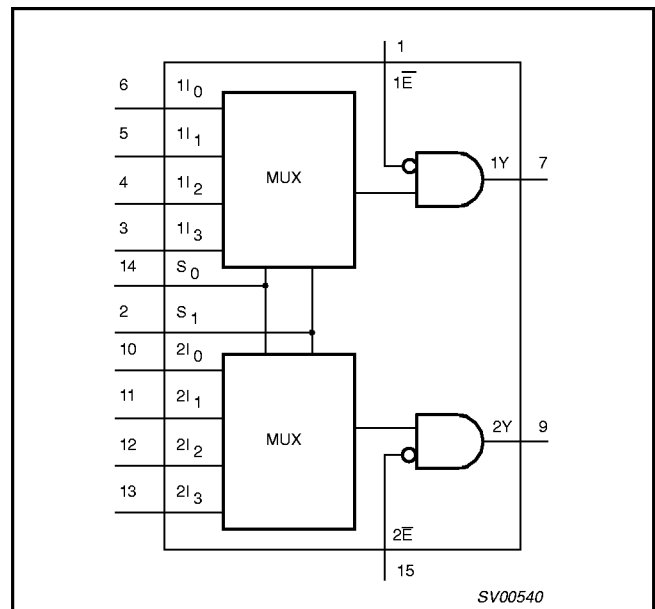

Dual 4-input multiplexer

74LV153

LOGIC DIAGRAM

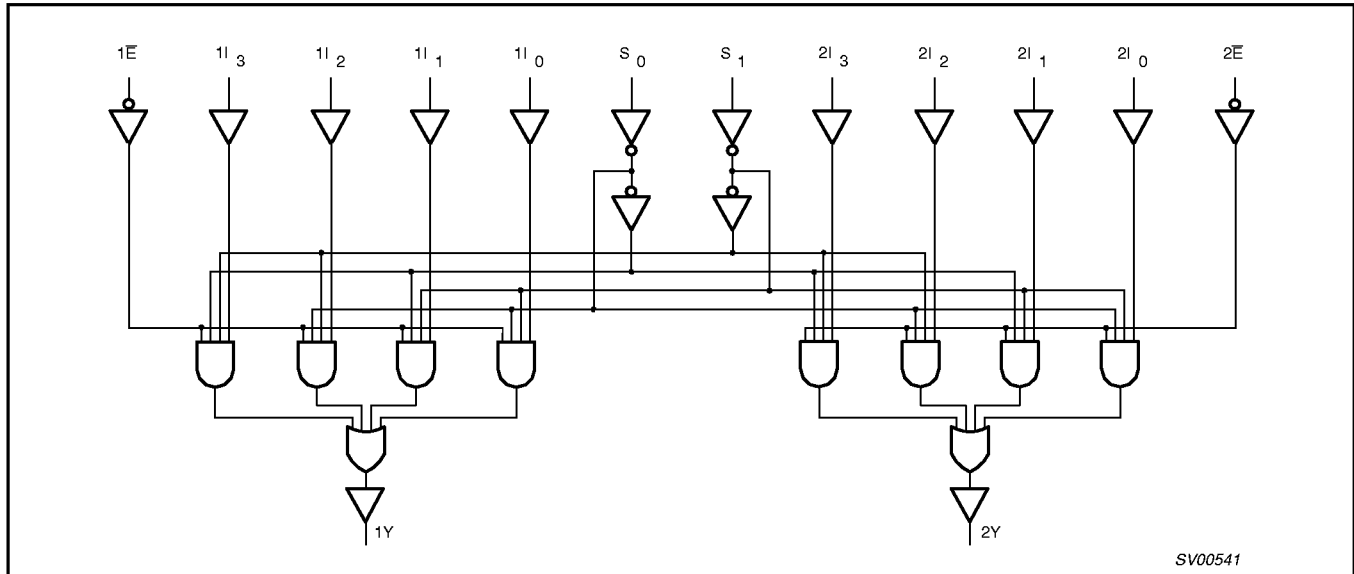

FUNCTION TABLE

SELECT INPUTS		DATA INPUTS				OUTPUT ENABLE	OUTPUT
S ₀	S ₁	n _{i0}	n _{i1}	n _{i2}	n _{i3}	nE	nY
X	X	X	X	X	X	H	L
L	L	L	X	X	X	L	L
L	L	H	X	X	X	L	H
H	L	X	L	X	X	L	L
H	L	X	H	X	X	L	H
L	H	X	X	L	X	L	L
L	H	X	X	H	X	L	H
H	H	X	X	X	L	L	L
H	H	X	X	X	H	L	H

NOTES:

- H = HIGH voltage level
- L = LOW voltage level
- X = don't care

Dual 4-input multiplexer

74LV153

RECOMMENDED OPERATING CONDITIONS

SYMBOL	PARAMETER	CONDITIONS	MIN	TYP	MAX	UNIT
V_{CC}	DC supply voltage	See Note 1	1.0	3.3	3.6	V
V_I	Input voltage		0	–	V_{CC}	V
V_O	Output voltage		0	–	V_{CC}	V
T_{amb}	Operating ambient temperature range in free air	See DC and AC characteristics	–40 –40		+85 +125	°C
t_r, t_f	Input rise and fall times	$V_{CC} = 1.0V$ to $2.0V$ $V_{CC} = 2.0V$ to $2.7V$ $V_{CC} = 2.7V$ to $3.6V$	– – –	– – –	500 200 100	ns/V

NOTE:

- The LV is guaranteed to function down to $V_{CC} = 1.0V$ (input levels GND or V_{CC}); DC characteristics are guaranteed from $V_{CC} = 1.2V$ to $V_{CC} = 3.6V$.

ABSOLUTE MAXIMUM RATINGS^{1, 2}

In accordance with the Absolute Maximum Rating System (IEC 134).

Voltages are referenced to GND (ground = 0 V).

SYMBOL	PARAMETER	CONDITIONS	RATING	UNIT
V_{CC}	DC supply voltage		–0.5 to +4.6	V
$\pm I_{IK}$	DC input diode current	$V_I < -0.5$ or $V_I > V_{CC} + 0.5V$	20	mA
$\pm I_{OK}$	DC output diode current	$V_O < -0.5$ or $V_O > V_{CC} + 0.5V$	50	mA
$\pm I_O$	DC output source or sink current – standard outputs	$-0.5V < V_O < V_{CC} + 0.5V$	25	mA
$\pm I_{GND},$ $\pm I_{CC}$	DC V_{CC} or GND current for types with – standard outputs		50	mA
T_{stg}	Storage temperature range		–65 to +150	°C
P_{TOT}	Power dissipation per package – plastic DIL – plastic mini-pack (SO) – plastic shrink mini-pack (SSOP and TSSOP)	for temperature range: –40 to +125°C above +70°C derate linearly with 12 mW/K above +70°C derate linearly with 8 mW/K above +60°C derate linearly with 5.5 mW/K	750 500 400	mW

NOTES:

- Stresses beyond those listed may cause permanent damage to the device. These are stress ratings only and functional operation of the device at these or any other conditions beyond those indicated under “recommended operating conditions” is not implied. Exposure to absolute-maximum-rated conditions for extended periods may affect device reliability.
- The input and output voltage ratings may be exceeded if the input and output current ratings are observed.

Dual 4-input multiplexer

74LV153

DC ELECTRICAL CHARACTERISTICS

Over recommended operating conditions. Voltages are referenced to GND (ground = 0 V).

SYMBOL	PARAMETER	TEST CONDITIONS	LIMITS					UNIT
			-40°C to +85°C			-40°C to +125°C		
			MIN	TYP ¹	MAX	MIN	MAX	
V _{IH}	HIGH level Input voltage	V _{CC} = 1.2 V	0.9			0.9		V
		V _{CC} = 2.0 V	1.4			1.4		
		V _{CC} = 2.7 to 3.6 V	2.0			2.0		
V _{IL}	LOW level Input voltage	V _{CC} = 1.2 V			0.3		0.3	V
		V _{CC} = 2.0 V			0.6		0.6	
		V _{CC} = 2.7 to 3.6 V			0.8		0.8	
V _{OH}	HIGH level output voltage; all outputs	V _{CC} = 1.2 V; V _I = V _{IH} or V _{IL} ; -I _O = 100µA		1.2				V
		V _{CC} = 2.0 V; V _I = V _{IH} or V _{IL} ; -I _O = 100µA	1.8	2.0		1.8		
		V _{CC} = 2.7 V; V _I = V _{IH} or V _{IL} ; -I _O = 100µA	2.5	2.7		2.5		
		V _{CC} = 3.0 V; V _I = V _{IH} or V _{IL} ; -I _O = 100µA	2.8	3.0		2.8		
V _{OH}	HIGH level output voltage; STANDARD outputs	V _{CC} = 3.0 V; V _I = V _{IH} or V _{IL} ; -I _O = 6mA	2.40	2.82		2.20		V
V _{OL}	LOW level output voltage; all outputs	V _{CC} = 1.2 V; V _I = V _{IH} or V _{IL} ; I _O = 100µA		0				V
		V _{CC} = 2.0 V; V _I = V _{IH} or V _{IL} ; I _O = 100µA		0	0.2		0.2	
		V _{CC} = 2.7 V; V _I = V _{IH} or V _{IL} ; I _O = 100µA		0	0.2		0.2	
		V _{CC} = 3.0 V; V _I = V _{IH} or V _{IL} ; I _O = 100µA		0	0.2		0.2	
V _{OL}	LOW level output voltage; STANDARD outputs	V _{CC} = 3.0 V; V _I = V _{IH} or V _{IL} ; I _O = 6mA		0.25	0.40		0.50	V
I _I	Input leakage current	V _{CC} = 3.6 V; V _I = V _{CC} or GND			1.0		1.0	µA
I _{CC}	Quiescent supply current; MSI	V _{CC} = 3.6 V; V _I = V _{CC} or GND; I _O = 0			20.0		160	µA
ΔI _{CC}	Additional quiescent supply current per input	V _{CC} = 2.7 V to 3.6 V; V _I = V _{CC} - 0.6 V			500		850	µA

NOTE:1. All typical values are measured at T_{amb} = 25°C.

Dual 4-input multiplexer

74LV153

AC CHARACTERISTICS

GND = 0V; $t_r = t_f = 2.5\text{ns}$; $C_L = 50\text{pF}$; $R_L = K\Omega$

SYMBOL	PARAMETER	WAVEFORM	CONDITION	LIMITS					UNIT
				-40 to +85 °C			-40 to +125 °C		
				$V_{CC}(\text{V})$	MIN	TYP ¹	MAX	MIN	
t_{PHL}/t_{PLH}	Propagation delay $1I_n$ to nY ; $2I_n$ to nY	Figures 1, 2	1.2		85				ns
			2.0		29	56		66	
			2.7		21	41		49	
			3.0 to 3.6		16 ²	33		39	
t_{PHL}/t_{PLH}	Propagation delay S_n to nY	Figures 1, 2	1.2		90				ns
			2.0		31	58		70	
			2.7		23	43		51	
			3.0 to 3.6		17 ²	34		41	
t_{PHL}/t_{PLH}	Propagation delay $n\bar{E}$ to nY	Figures 1, 2	1.2		60				ns
			2.0		20	39		46	
			2.7		15	29		34	
			3.0 to 3.6		11 ²	23		27	

NOTES:

1. Unless otherwise stated, all typical values are measured at $T_{amb} = 25^\circ\text{C}$
2. Typical values are measured at $V_{CC} = 3.3\text{V}$.

AC WAVEFORMS

$V_M = 1.5\text{V}$ at $V_{CC} \geq 2.7\text{V}$;

$V_M = 0.5\text{V} \times V_{CC}$ at $V_{CC} < 2.7\text{V}$;

V_{OL} and V_{OH} are the typical output voltage drop that occur with the output load.

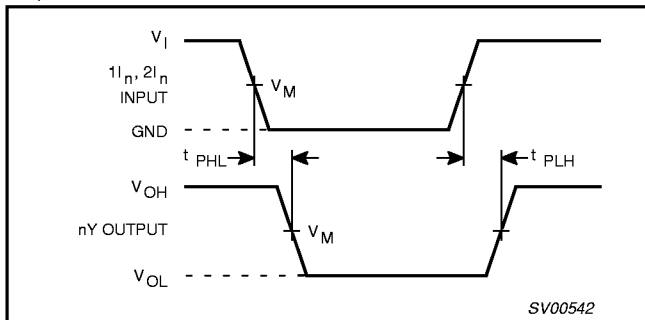

Figure 1. Input ($1I_n$, $2I_n$) to output ($1Y$, $2Y$) propagation delays.

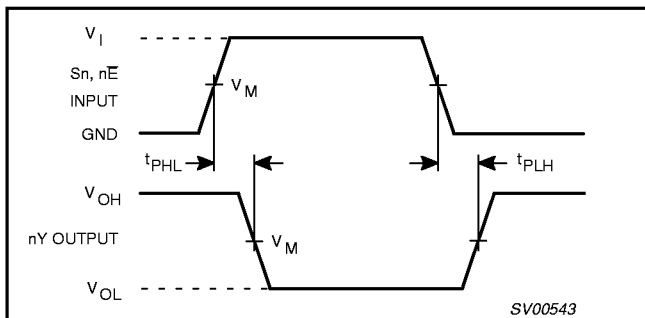

Figure 2. Select input (S_0 , S_1) and the output enable input (\bar{E}) to output (nY_n) propagation delays.

TEST CIRCUIT

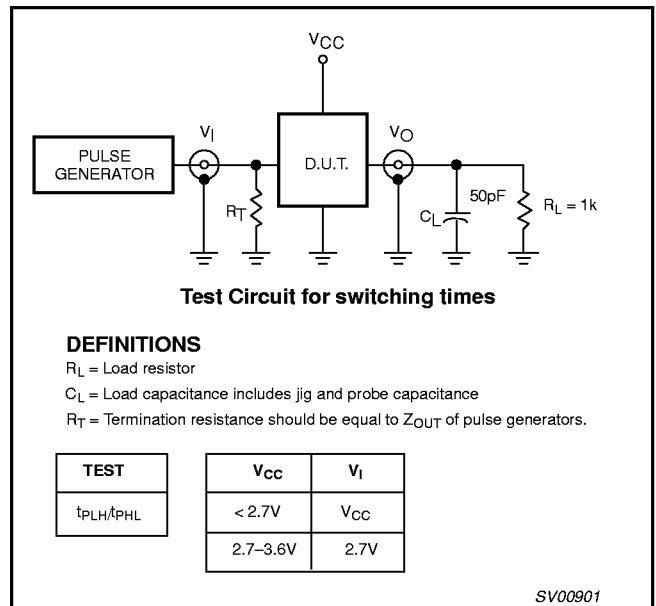

Figure 3. Load circuitry for switching times.

Dual 4-input multiplexer

74LV153

DIP16: plastic dual in-line package; 16 leads (300 mil)

SOT38-4

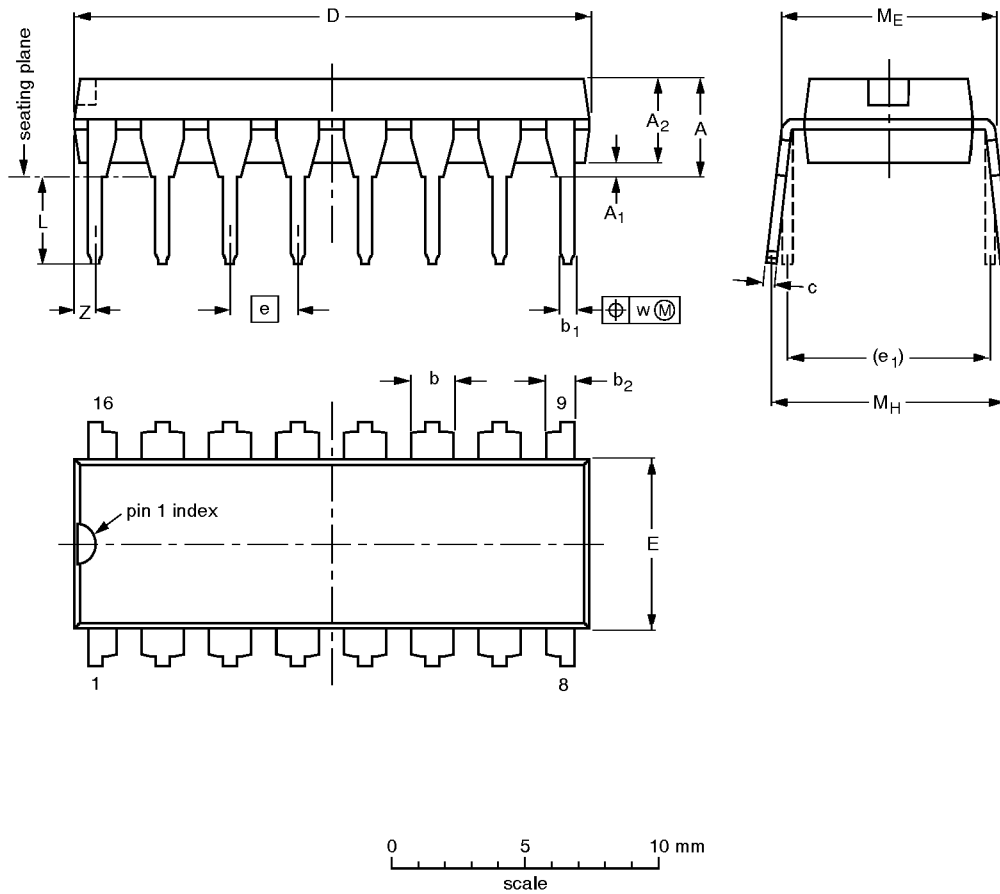

DIMENSIONS (inch dimensions are derived from the original mm dimensions)

UNIT	A max.	A ₁ min.	A ₂ max.	b	b ₁	b ₂	c	D ⁽¹⁾	E ⁽¹⁾	e	e ₁	L	M _E	M _H	w	Z ⁽¹⁾ max.
mm	4.2	0.51	3.2	1.73 1.30	0.53 0.38	1.25 0.85	0.36 0.23	19.50 18.55	6.48 6.20	2.54	7.62	3.60 3.05	8.25 7.80	10.0 8.3	0.254	0.76
inches	0.17	0.020	0.13	0.068 0.051	0.021 0.015	0.049 0.033	0.014 0.009	0.77 0.73	0.26 0.24	0.10	0.30	0.14 0.12	0.32 0.31	0.39 0.33	0.01	0.030

Note

1. Plastic or metal protrusions of 0.25 mm maximum per side are not included.

OUTLINE VERSION	REFERENCES				EUROPEAN PROJECTION	ISSUE DATE
	IEC	JEDEC	EIAJ			
SOT38-4						92-11-17 95-01-14

Dual 4-input multiplexer

74LV153

SO16: plastic small outline package; 16 leads; body width 3.9 mm

SOT109-1

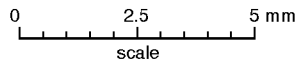
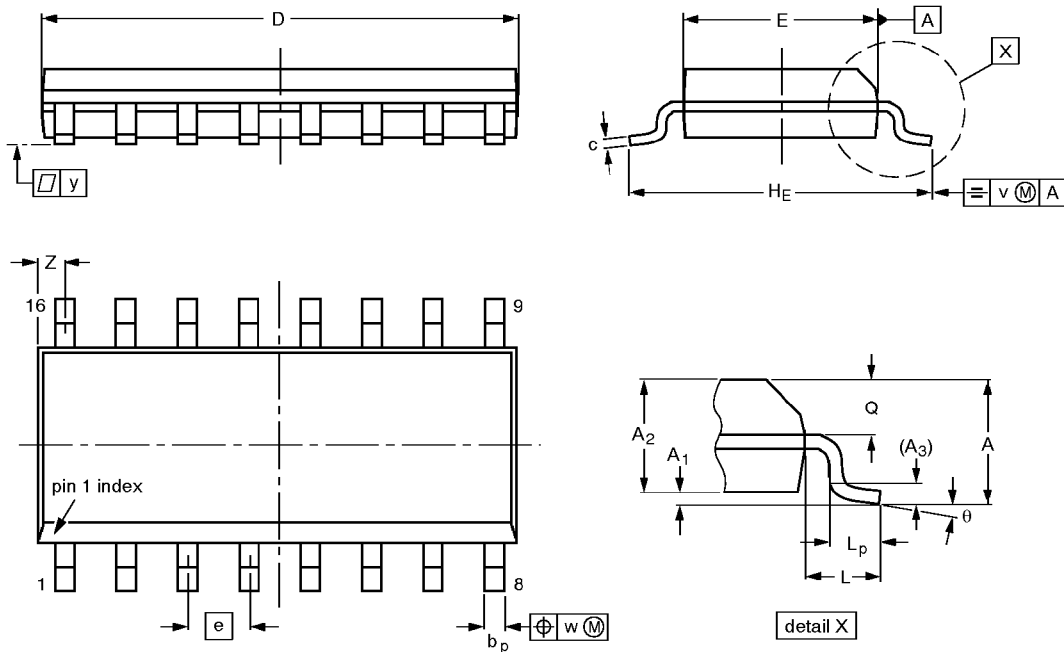

DIMENSIONS (inch dimensions are derived from the original mm dimensions)

UNIT	A max.	A ₁	A ₂	A ₃	b _p	c	D ⁽¹⁾	E ⁽¹⁾	e	H _E	L	L _p	Q	v	w	y	Z ⁽¹⁾	θ
mm	1.75	0.25 0.10	1.45 1.25	0.25	0.49 0.36	0.25 0.19	10.0 9.8	4.0 3.8	1.27	6.2 5.8	1.05	1.0 0.4	0.7 0.6	0.25	0.25	0.1	0.7 0.3	8° 0°
inches	0.069	0.0098 0.0039	0.057 0.049	0.01	0.019 0.014	0.0098 0.0075	0.39 0.38	0.16 0.15	0.050	0.24 0.23	0.041	0.039 0.016	0.028 0.020	0.01	0.01	0.004	0.028 0.012	

Note

1. Plastic or metal protrusions of 0.15 mm maximum per side are not included.

OUTLINE VERSION	REFERENCES				EUROPEAN PROJECTION	ISSUE DATE
	IEC	JEDEC	EIAJ			
SOT109-1	076E07S	MS-012AC				91-08-13 95-01-23

Dual 4-input multiplexer

74LV153

SSOP16: plastic shrink small outline package; 16 leads; body width 5.3 mm

SOT338-1

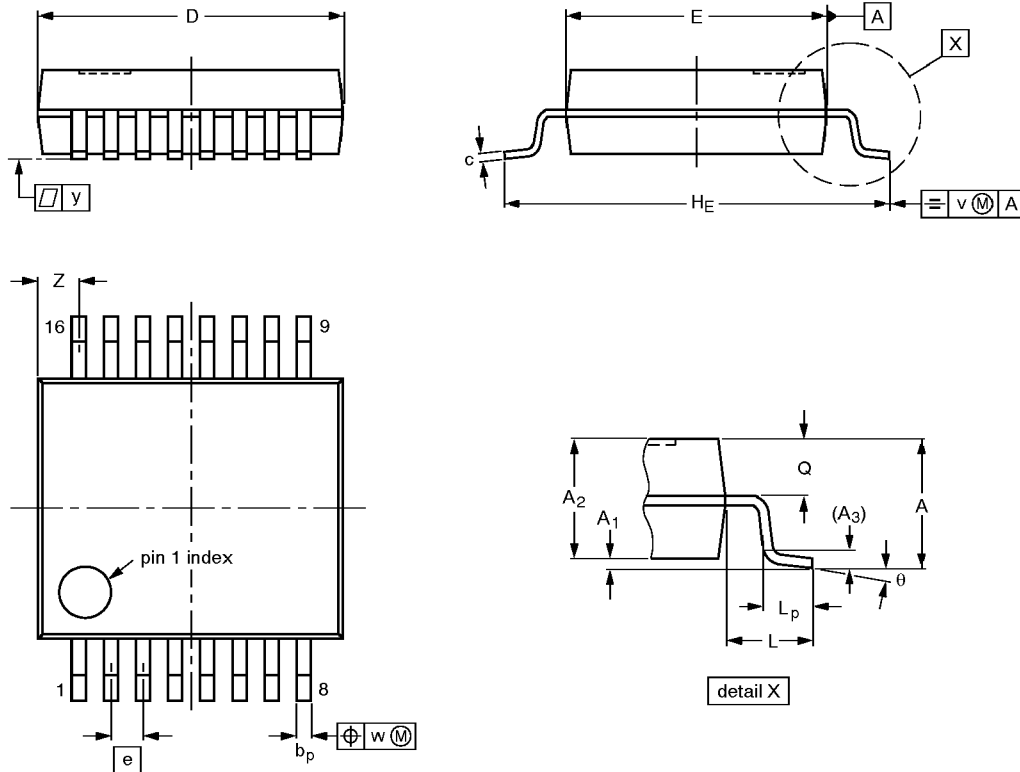

DIMENSIONS (mm are the original dimensions)

UNIT	A max.	A ₁	A ₂	A ₃	b _p	c	D ⁽¹⁾	E ⁽¹⁾	e	H _E	L	L _p	Q	v	w	y	Z ⁽¹⁾	θ
mm	2.0	0.21 0.05	1.80 1.65	0.25	0.38 0.25	0.20 0.09	6.4 6.0	5.4 5.2	0.65	7.9 7.6	1.25	1.03 0.63	0.9 0.7	0.2	0.13	0.1	1.00 0.55	8° 0°

Note

1. Plastic or metal protrusions of 0.25 mm maximum per side are not included.

OUTLINE VERSION	REFERENCES				EUROPEAN PROJECTION	ISSUE DATE
	IEC	JEDEC	EIAJ			
SOT338-1		MO-150AC				94-01-14 95-02-04

Dual 4-input multiplexer

74LV153

TSSOP16: plastic thin shrink small outline package; 16 leads; body width 4.4 mm

SOT403-1

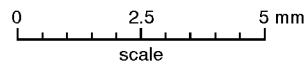
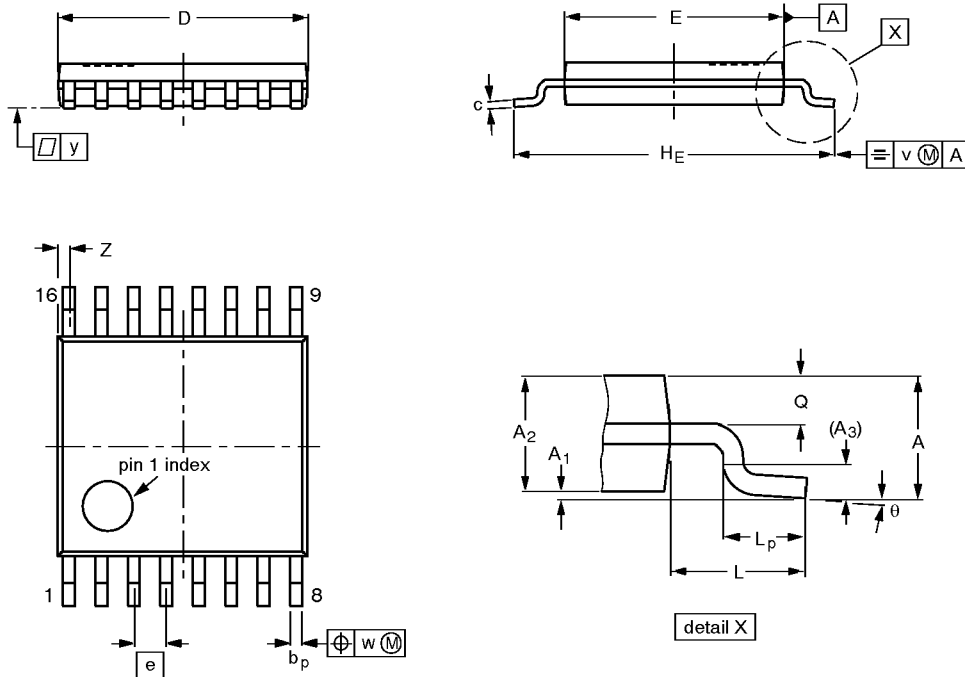

DIMENSIONS (mm are the original dimensions)

UNIT	A max.	A ₁	A ₂	A ₃	b _p	c	D ⁽¹⁾	E ⁽²⁾	e	H _E	L	L _p	Q	v	w	y	Z ⁽¹⁾	θ
mm	1.10	0.15 0.05	0.95 0.80	0.25	0.30 0.19	0.2 0.1	5.1 4.9	4.5 4.3	0.65	6.6 6.2	1.0	0.75 0.50	0.4 0.3	0.2	0.13	0.1	0.40 0.06	8° 0°

Notes

1. Plastic or metal protrusions of 0.15 mm maximum per side are not included.
2. Plastic interlead protrusions of 0.25 mm maximum per side are not included.

OUTLINE VERSION	REFERENCES				EUROPEAN PROJECTION	ISSUE DATE
	IEC	JEDEC	EIAJ			
SOT403-1		MO-153				-94-07-12 95-04-04

Dual 4-input multiplexer

74LV153

NOTES

Dual 4-input multiplexer

74LV153

NOTES

Dual 4-input multiplexer

74LV153

DEFINITIONS

Data Sheet Identification	Product Status	Definition
<i>Objective Specification</i>	Formative or in Design	This data sheet contains the design target or goal specifications for product development. Specifications may change in any manner without notice.
<i>Preliminary Specification</i>	Preproduction Product	This data sheet contains preliminary data, and supplementary data will be published at a later date. Philips Semiconductors reserves the right to make changes at any time without notice in order to improve design and supply the best possible product.
<i>Product Specification</i>	Full Production	This data sheet contains Final Specifications. Philips Semiconductors reserves the right to make changes at any time without notice, in order to improve design and supply the best possible product.

Philips Semiconductors and Philips Electronics North America Corporation reserve the right to make changes, without notice, in the products, including circuits, standard cells, and/or software, described or contained herein in order to improve design and/or performance. Philips Semiconductors assumes no responsibility or liability for the use of any of these products, conveys no license or title under any patent, copyright, or mask work right to these products, and makes no representations or warranties that these products are free from patent, copyright, or mask work right infringement, unless otherwise specified. Applications that are described herein for any of these products are for illustrative purposes only. Philips Semiconductors makes no representation or warranty that such applications will be suitable for the specified use without further testing or modification.

LIFE SUPPORT APPLICATIONS

Philips Semiconductors and Philips Electronics North America Corporation Products are not designed for use in life support appliances, devices, or systems where malfunction of a Philips Semiconductors and Philips Electronics North America Corporation Product can reasonably be expected to result in a personal injury. Philips Semiconductors and Philips Electronics North America Corporation customers using or selling Philips Semiconductors and Philips Electronics North America Corporation Products for use in such applications do so at their own risk and agree to fully indemnify Philips Semiconductors and Philips Electronics North America Corporation for any damages resulting from such improper use or sale.

Philips Semiconductors
 811 East Arques Avenue
 P.O. Box 3409
 Sunnyvale, California 94088-3409
 Telephone 800-234-7381

© Copyright Philips Electronics North America Corporation 1998
 All rights reserved. Printed in U.S.A.

print code

Date of release: 05-96

Document order number:

9397-750-04425

Let's make things better.