

16-bit buffer/line driver; (3-State)

74LVC16541A
74LVCH16541A

FEATURES

- 5 volt tolerant inputs/outputs for interfacing with 5V logic
- Wide supply voltage range of 1.2 V to 3.6 V
- Complies with JEDEC standard no. 8-1A
- CMOS low power consumption
- MULTIBYTE™ flow-through standard pin-out architecture
- Low inductance multiple power and ground pins for minimum noise and ground bounce
- Direct interface with TTL levels
- All data inputs have bushold (74LVCH16541A only)

DESCRIPTION

The 74LVC(H)16541A is a high-performance, low-power, low-voltage, Si-gate CMOS device, superior to most advanced CMOS compatible TTL families. Inputs can be driven from either 3.3V or 5V devices. In 3-State operation, outputs can handle 5V. These features allow the use of these devices in a mixed 3.3V/5V environment.

The 74LVC(H)16541A is a 16-bit inverting buffer/line driver with 3-State outputs. The 3-State outputs are controlled by the output enable inputs $1OE_n$ and $2OE_n$. A HIGH on nOE_n causes the outputs to assume a high impedance OFF-state.

The 74LVC(H)16541A is identical to the 74LVC(H)16540A but has non-inverting outputs.

PIN CONFIGURATION

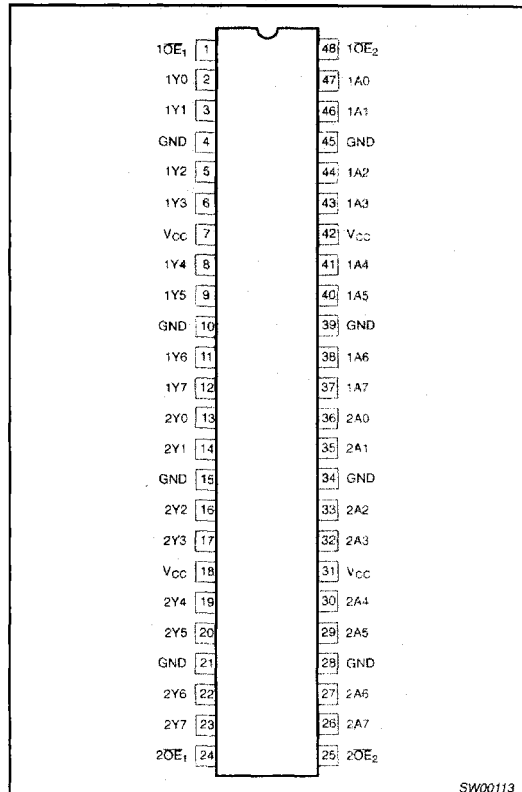

SW00113

ORDERING INFORMATION

PACKAGES	TEMPERATURE RANGE	OUTSIDE NORTH AMERICA	NORTH AMERICA	DWG NUMBER
48-Pin Plastic SSOP Type III	-40°C to +85°C	74LVC16541A DL	VC16541A DL	SOT370-1
48-Pin Plastic TSSOP Type II	-40°C to +85°C	74LVC16541A DGG	VC16541A DGG	SOT362-1
48-Pin Plastic SSOP Type III	-40°C to +85°C	74LVCH16541A DL	VCH16541A DL	SOT370-1
48-Pin Plastic TSSOP Type II	-40°C to +85°C	74LVCH16541A DGG	VCH16541A DGG	SOT362-1

QUICK REFERENCE DATA

GND = 0V; $T_{amb} = 25^\circ\text{C}$; $t_r = t_f \leq 2.5\text{ns}$

SYMBOL	PARAMETER	CONDITIONS	TYPICAL	UNIT
t_{PHL}/t_{PLH}	Propagation delay 1An to 1Yn; 2An to 2Yn	$C_L = 50\text{pF}$ $V_{CC} = 3.3\text{V}$	3.5	ns
C_i	Input capacitance		3.0	pF
C_{PD}	Power dissipation capacitance per buffer	$V_i = \text{GND to } V_{CC}^1$	30	pF

NOTES:

1. C_{PD} is used to determine the dynamic power dissipation (P_D in μW):

$P_D = C_{PD} \times V_{CC}^2 \times f_i + \sum (C_L \times V_{CC}^2 \times f_o)$ where:

f_i = input frequency in MHz; C_L = output load capacity in pF;

f_o = output frequency in MHz; V_{CC} = supply voltage in V;

$\sum (C_L \times V_{CC}^2 \times f_o)$ = sum of outputs.

16-bit buffer/line driver; (3-State)

74LVC16541A
74LVCH16541A

PIN DESCRIPTION

PIN NUMBER	SYMBOL	NAME AND FUNCTION
1, 24	nOE ₁	Output enable input (active LOW)
2, 3, 5, 6, 8, 9, 11, 12	1Y0 to 1Y7	Data outputs
4, 10, 15, 21, 28, 34, 39, 45	GND	Ground (0V)
7, 18, 31, 42	V _{CC}	Positive supply voltage
13, 14, 16, 17, 19, 20, 22, 23	2Y0 to 2Y7	Data outputs
25, 48	nOE ₂	Output enable input (active LOW)
36, 35, 33, 32, 30, 29, 27, 26	2A0 to 2A7	Data inputs
47, 46, 44, 43, 41, 40, 38, 37	1A0 to 1A7	Data inputs

LOGIC SYMBOL (IEEE/IEC)

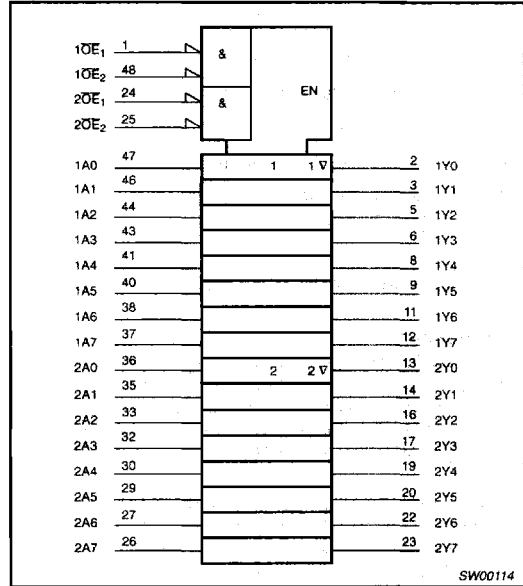

LOGIC SYMBOL

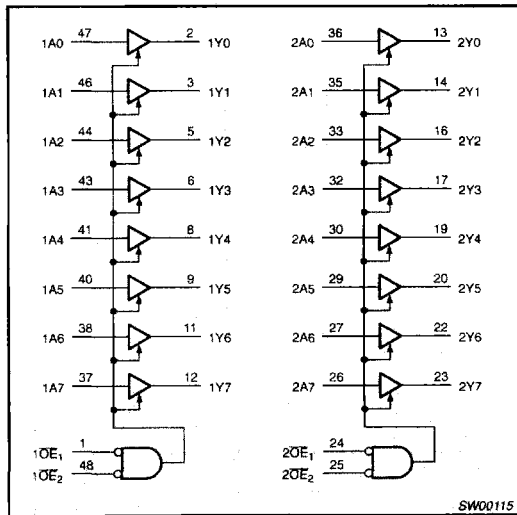

BUSHOLD CIRCUIT

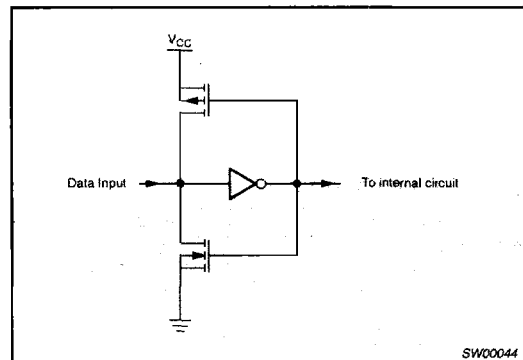

FUNCTION TABLE

INPUTS			OUTPUT
nOE ₁	nOE ₂	nAn	nYn
L	L	L	L
L	L	H	H
X	H	X	Z
H	X	X	Z

H = HIGH voltage level
L = LOW voltage level
X = don't care
Z = high impedance OFF-state

16-bit buffer/line driver; (3-State)

74LVC16541A
74LVCH16541A**ABSOLUTE MAXIMUM VALUES^{1, 2}**

In accordance with the Absolute Maximum Rating System (IEC 134) Voltages are referenced to GND (ground = 0V)

SYMBOL	PARAMETER	CONDITIONS	MIN	MAX	UNIT
V_{CC}	DC supply voltage		-0.5	+6.5	V
I_{IK}	DC input diode current	$V_I < 0$	-	-50	mA
V_I	DC input voltage	Note 3	-0.5	+6.5	V
I_{OK}	DC output diode current	$V_O > V_{CC}$ or $V_O < 0$	-	± 50	mA
V_O	DC output voltage; output HIGH or LOW state	Note 3	-0.5	$V_{CC} + 0.5$	V
V_O	DC output voltage; output 3-State	Note 3	-0.5	6.5	V
I_O	DC output source or sink current	$V_O = 0$ to V_{CC}	-	± 50	mA
I_{GND}, I_{CC}	DC V_{CC} or GND current		-	± 100	mA
T_{stg}	Storage temperature range		-60	+150	$^{\circ}\text{C}$
P_{tot}	Power dissipation per package - SO package - SSOP and TSSOP package	Above +70 $^{\circ}\text{C}$ derate linearly 8mW/K Above +60 $^{\circ}\text{C}$ derate linearly 5.5mW/K	-	500	mW

NOTES:

- Stresses beyond those listed may cause permanent damage to the device. These are stress ratings only and functional operation of the device at these or any other conditions beyond those indicated under "recommended operating conditions" is not implied. Exposure to absolute-maximum-rated conditions for extended periods may affect device reliability.
- The performance capability of a high-performance integrated circuit in conjunction with its thermal environment can create junction temperatures which are detrimental to reliability. The maximum junction temperature of this integrated circuit should not exceed 150 $^{\circ}\text{C}$.
- The input and output voltage ratings may be exceeded if the input and output clamp current ratings are observed.

RECOMMENDED OPERATING CONDITIONS

SYMBOL	PARAMETER	CONDITIONS	MIN.	MAX.	UNIT
V_{CC}	DC supply voltage (for max. speed performance)		2.7	3.6	V
V_{CC}	DC supply voltage (for low-voltage applications)		1.2	3.6	V
V_I	DC input voltage range		0	5.5	V
V_O	DC output voltage range; output HIGH or LOW state		0	V_{CC}	V
V_O	DC output voltage range; output 3-State		0	5.5	V
T_{amb}	Operating ambient temperature range in free air	See DC and AC characteristics for individual device	-40	+85	$^{\circ}\text{C}$
t_r, t_f	Input rise and fall times	$V_{CC} = 1.2$ to 2.7V $V_{CC} = 2.7$ to 3.6V	0	20	ns/V
			0	10	

16-bit buffer/line driver; (3-State)

74LVC16541A
74LVCH16541A**DC CHARACTERISTICS**

Over recommended operating conditions

Voltages are referenced to GND (ground = 0V)

SYMBOL	PARAMETER	TEST CONDITIONS	LIMITS			UNIT
			Temp = -40°C to +85°C			
			MIN	TYP ¹	MAX	
V _{IH}	HIGH level input voltage	V _{CC} = 1.2V	V _{CC}			V
		V _{CC} = 2.7 to 3.6V	2.0			
V _{IL}	LOW level input voltage	V _{CC} = 1.2V			GND	V
		V _{CC} = 2.7 to 3.6V			0.8	
V _{OH}	HIGH level output voltage	V _{CC} = 2.7; V _I = V _{IH} or V _{IL} ; I _O = -12mA	V _{CC} -0.5			V
		V _{CC} = 3.0V; V _I = V _{IH} or V _{IL} ; I _O = -100µA	V _{CC} -0.2	V _{CC}		
		V _{CC} = 3.0V; V _I = V _{IH} or V _{IL} ; I _O = -18mA	V _{CC} -0.6			
		V _{CC} = 3.0V; V _I = V _{IH} or V _{IL} ; I _O = -24mA	V _{CC} -0.8			
V _{OH}	HIGH level output voltage	V _{CC} = 2.7; V _I = V _{IH} or V _{IL} ; I _O = -6mA ⁷	V _{CC} -0.5			V
		V _{CC} = 3.0V; V _I = V _{IH} or V _{IL} ; I _O = -100µA ⁷	V _{CC} -0.2	V _{CC}		
		V _{CC} = 3.0V; V _I = V _{IH} or V _{IL} ; I _O = -12mA ⁷	V _{CC} -1.0			
V _{OL}	LOW level output voltage	V _{CC} = 2.7V; V _I = V _{IH} or V _{IL} ; I _O = 12mA			0.40	V
		V _{CC} = 3.0V; V _I = V _{IH} or V _{IL} ; I _O = 100µA			0.20	
		V _{CC} = 3.0V; V _I = V _{IH} or V _{IL} ; I _O = 24mA			0.55	
V _{OL}	LOW level output voltage	V _{CC} = 2.7V; V _I = V _{IH} or V _{IL} ; I _O = 6mA ⁷			0.40	V
		V _{CC} = 3.0V; V _I = V _{IH} or V _{IL} ; I _O = 100µA ⁷			0.20	
		V _{CC} = 3.0V; V _I = V _{IH} or V _{IL} ; I _O = 12mA ⁷			0.55	
I _I	Input leakage current	V _{CC} = 3.6V; V _I = 5.5V or GND; not for I/O pins ⁶		±0.1	±5	µA
I _{IHZ} /I _{ILZ}	Input current for common I/O pins	V _{CC} = 3.6V; V _I = 5.5V or GND; output disabled ⁶		±0.1	±10	µA
I _{OZ}	3-State output OFF-state current	V _{CC} = 3.6V; V _I = V _{IH} or V _{IL} ; V _O 5.5V or GND		0.1	±10	µA
I _{OFF}	Power off leakage current	V _{CC} = 0.0V; V _I or V _O = 5.5V			±10	µA
I _{CC}	Quiescent supply current	V _{CC} = 3.6V; V _I = V _{CC} or GND; I _O = 0		0.1	20	µA
ΔI _{CC}	Additional quiescent supply current given per input pin	V _{CC} = 2.7 to 3.6V; V _I = V _{CC} - 0.6V; I _O = 0		5	500	µA
I _{BHL}	Bus hold LOW sustaining current	V _{CC} = 3.0V; V _I = 0.8V ^{2, 3, 4}	75			µA
I _{BHH}	Bus hold HIGH sustaining current	V _{CC} = 3.0V; V _I = 2.0V ^{2, 3, 4}	-75			µA
I _{BHLO}	Bus hold LOW overdrive current	V _{CC} = 3.6V ^{2, 3, 5}	500			µA
I _{BHHO}	Bus hold HIGH overdrive current	V _{CC} = 3.6V ^{2, 3, 5}	-500			µA

NOTES:

- All typical values are at V_{CC} = 3.3V and T_{amb} = 25°C.
- Valid for data inputs of bus hold parts (LVCH16-A) only.
- For data inputs only, control inputs do not have a bus hold circuit.
- The specified sustaining current at the data input holds the input below the specified V_I level.
- The specified overdrive current at the data input forces the data input to the opposite logic input state.
- For bus hold parts, the bus hold circuit is switched off when V_I exceeds V_{CC} allowing 5.5V on the input terminal.
- For data outputs of damping resistor parts (LVC(H)16-A only).

16-bit buffer/line driver; (3-State)

74LVC16541A
74LVCH16541A

AC CHARACTERISTICS

GND = 0V; $t_R = t_F = 2.5\text{ns}$; $C_L = 50\text{pF}$; $R_L = 500\Omega$; $T_{amb} = -40^\circ\text{C}$ to $+85^\circ\text{C}$.

SYMBOL	PARAMETER	WAVEFORM	LIMITS				UNIT
			$V_{CC} = 3.3V \pm 0.3V$		$V_{CC} = 2.7V$		
			MIN	TYP ¹	MAX	MAX	
t_{PHL} t_{PLH}	Propagation delay 1An to 1Yn; 2An to 2Yn	1, 3		5.2	6.2	ns	
t_{PZH} t_{PZL}	3-State output enable time 1OE _n to 1Y _n ; 2OE _n to 2Y _n	2, 3		7.5	8.5	ns	
t_{PHZ} t_{PLZ}	3-State output disable time 1OE _n to 1Y _n ; 2OE _n to 2Y _n	2, 3		7.0	8.0	ns	

NOTE:

1. All typical values are at $V_{CC} = 3.3V$ and $T_{amb} = 25^\circ\text{C}$.

AC WAVEFORMS

$V_M = 1.5V$ at $V_{CC} \geq 2.7V$; $V_M = 0.5 V_{CC}$ at $V_{CC} < 2.7V$.
 V_{OL} and V_{OH} are the typical output voltage drop that occur with the output load.
 $V_X = V_{OL} + 0.3V$ at $V_{CC} \geq 2.7V$; $V_X = V_{OL} + 0.1 V_{CC}$ at $V_{CC} < 2.7V$
 $V_Y = V_{OH} - 0.3V$ at $V_{CC} \geq 2.7V$; $V_Y = V_{OH} - 0.1 V_{CC}$ at $V_{CC} < 2.7V$

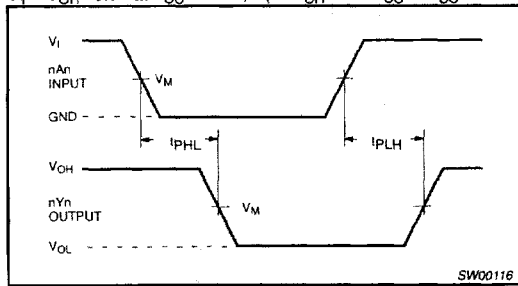

Waveform 1. Waveforms showing the input (An) to output (Yn) propagation delay times

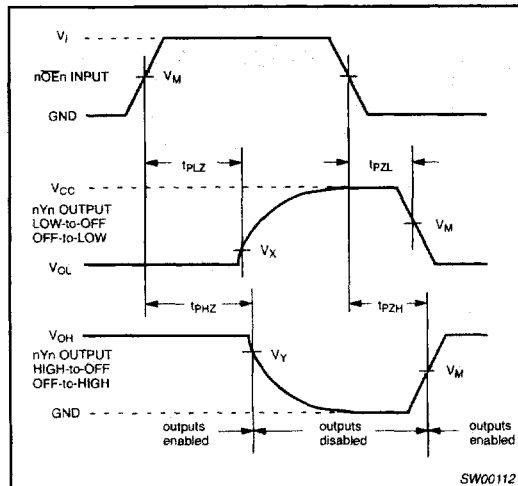

Waveform 2. Waveforms showing the 3-State enable and disable times

TEST CIRCUIT

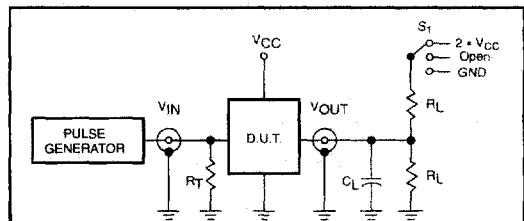

Test Circuit for 3-State Outputs

SWITCH POSITION

TEST	SWITCH
t_{PLH}/t_{PHL}	Open
t_{PLZ}/t_{PZL}	$2 * V_{CC}$
t_{PHZ}/t_{PZH}	GND

V_{CC}	V_I
$< 2.7V$	V_{CC}
$2.7 - 3.6V$	$2.7V$

DEFINITIONS

R_L = Load resistor; see AC CHARACTERISTICS for value.
 C_L = Load capacitance includes jig and probe capacitance; see AC CHARACTERISTICS for value.
 R_T = Termination resistance should be equal to Z_{OUT} of pulse generators.

Waveform 3. Load circuitry for switching times