

TC74ACT00 / F / FN

QUAD 2-INPUT NAND GATE

The TC74ACT00 is an advanced high speed CMOS 2-INPUT NAND GATE fabricated with silicon gate and double-layer metal wiring C² MOS technology.

It achieves the high speed operation similar to equivalent Bipolar Schottky TTL while maintaining the CMOS low power dissipation.

This device may be used as a level converter for interfacing TTL or NMOS to High Speed CMOS. The inputs are compatible with TTL, NMOS and CMOS output voltage levels.

All inputs are equipped with protection circuits against static discharge or transient excess voltage.

FEATURES:

- High Speed $t_{pd} = 4.0\text{ns}$ (typ.) at $V_{CC} = 5\text{V}$
- Low Power Dissipation $I_{CC} = 4\mu\text{A}$ (Max.) at $T_a = 25^\circ\text{C}$
- Compatible with TTL outputs $V_{IL} = 0.8\text{V}$ (Max.)
 $V_{IH} = 2.0\text{V}$ (Min.)
- Symmetrical Output Impedance ... $|I_{OH}| = I_{OL} = 24\text{mA}$ (Min.)
Capability of driving 50Ω transmission lines.
- Balanced Propagation Delays $t_{pLH} = t_{pHL}$
- Pin and Function Compatible with 74F00

IEC LOGIC SYMBOL

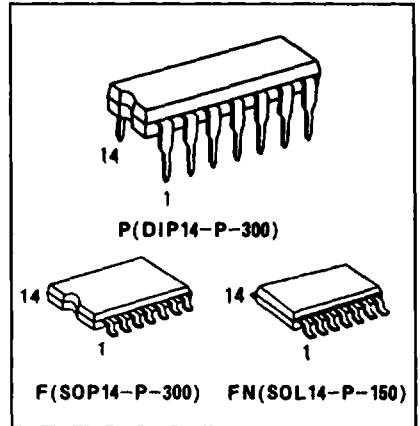
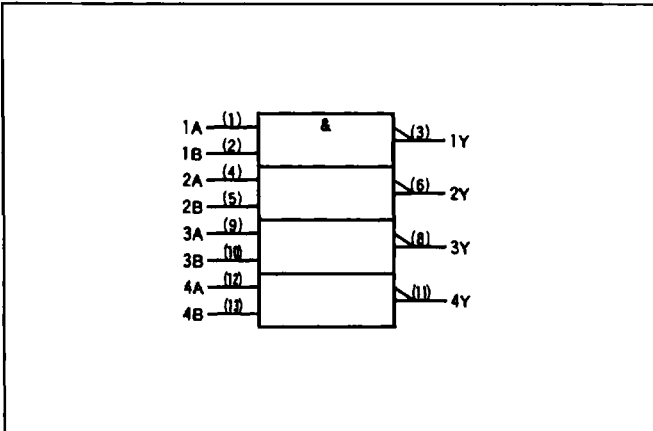

PIN ASSIGNMENT

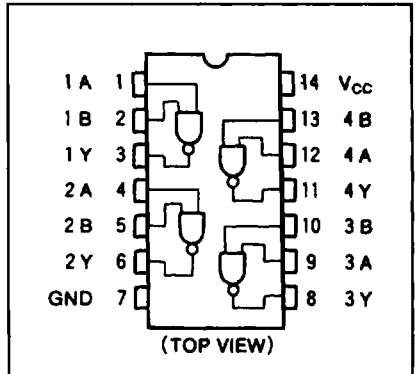

TRUTH TABLE

A	B	Y
L	L	H
L	H	H
H	L	H
H	H	L

ABSOLUTE MAXIMUM RATINGS

PARAMETER	SYMBOL	VALUE	UNIT
Supply Voltage Range	V_{CC}	-0.5 ~ 6.0	V
DC Input Voltage	V_{IN}	-0.5 ~ $V_{CC} + 0.5$	V
DC Output Voltage	V_{OUT}	-0.5 ~ $V_{CC} + 0.5$	V
Input Diode Current	I_{IK}	±20	mA
Output Diode Current	I_{OK}	±50	mA
DC Output Current	I_{OUT}	±50	mA
DC V_{CC} /Ground Current	I_{CC}	±100	mA
Power Dissipation	P_D	500(DIP)* / 180(SOP)	mW
Storage Temperature	T_{stg}	-65 ~ 150	°C
Lead Temperature 10sec	T_L	300	°C

*500mW in the range of $T_a = -40^\circ\text{C} \sim 65^\circ\text{C}$. From $T_a = 65^\circ\text{C}$ to 85°C a derating factor of $-10\text{mW}/^\circ\text{C}$ shall be applied until 300mW.

RECOMMENDED OPERATING CONDITIONS

PARAMETER	SYMBOL	VALUE	UNIT
Supply Voltage	V_{CC}	4.5 ~ 5.5	V
Input Voltage	V_{IN}	0 ~ V_{CC}	V
Output Voltage	V_{OUT}	0 ~ V_{CC}	V
Operating Temperature	T_{opr}	-40 ~ 85	°C
Input Rise and Fall Time	dt/dv	0 ~ 10	ns/v

DC ELECTRICAL CHARACTERISTICS

PARAMETER	SYMBOL	TEST CONDITION	V_{CC}	$T_a = 25^\circ\text{C}$			$T_a = -40 \sim 85^\circ\text{C}$		UNIT	
				MIN.	TYP.	MAX.	MIN.	MAX.		
High-Level Input Voltage	V_{IH}		4.5 } 5.5	2.0	-	-	2.0	-	V	
Low-Level Input Voltage	V_{IL}		4.5 } 5.5	-	-	0.8	-	0.8	V	
High-Level Output Voltage	V_{OH}	$V_{IN} = V_{IH}$ or V_{IL}	$I_{OH} = -50 \mu\text{A}$	4.5	4.4	4.5	-	4.4	-	V
			$I_{OH} = -24\text{mA}$	4.5	3.94	-	-	3.80	-	
			$I_{OH} = -75\text{mA}^*$	5.5	-	-	-	3.85	-	
Low-Level Output Voltage	V_{OL}	$V_{IN} = V_{IH}$	$I_{OL} = 50 \mu\text{A}$	4.5	-	0.0	0.1	-	0.1	V
			$I_{OL} = 24\text{mA}$	4.5	-	-	0.36	-	0.44	
			$I_{OL} = 75\text{mA}^*$	5.5	-	-	-	-	1.65	
Input Leakage Current	I_{IN}	$V_{IN} = V_{CC}$ or GND	5.5	-	-	±0.1	-	±1.0	μA	
	I_{CC}	$V_{IN} = V_{CC}$ or GND	5.5	-	-	4.0	-	40.0		
Quiescent Supply Current	ΔI_{CC}	PER INPUT: $V_{IN} = 3.4\text{V}$ OTHER INPUT: V_{CC} or GND	5.5	-	-	1.35	-	1.5	mA	

* This spec indicates the capability of driving 50Ω transmission lines.
One output should be tested at a time for a 10ms maximum duration.

TC74ACT00P/F/FN

AC ELECTRICAL CHARACTERISTICS ($C_L=50\text{pF}$, $R_L=500\Omega$, Input $t_r=t_f=3\text{ns}$)

PARAMETER	SYMBOL	TEST CONDITION	$T_a=25^\circ\text{C}$			$T_a=-40\sim 85^\circ\text{C}$		UNIT	
			V_{CC}	MIN.	TYP.	MAX.	MIN.		MAX.
Propagation Delay Time	t_{pLH} t_{pHL}		5.0 ± 0.5	-	4.7	7.9	1.0	9.5	ns
Input Capacitance	C_{IN}		-	5	10	-	10	pF	
Power Dissipation Capacitance	$C_{PD(1)}$		-	23	-	-	-	-	pF

Note (1) C_{PD} is defined as the value of the internal equivalent capacitance which is calculated from the operating current consumption without load.

Average operating current can be obtained by the equation:

$$I_{CC(ave)} = C_{PD} \cdot V_{CC} \cdot f_{IN} + I_{CC}/4 (\text{per Gate})$$