

TYPES SN54S436, SN54S437, SN74S436, SN74S437 LINE DRIVER/MEMORY DRIVER CIRCUITS

D2630, JANUARY 1981—REVISED APRIL 1985

MOS MEMORY INTERFACE

- Can Drive High-Impedance Loads
- Interchangeable with National DS16149 DS16179 Drivers
- High-Speed Switching
- Minimum Input Current Required
- Damping Output Resistor Reduces Transients

SN54S436, SN54S437 ... J OR W PACKAGE
SN74S436, SN74S437 ... D, J OR N PACKAGE
(TOP VIEW)

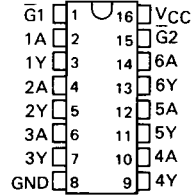

SN54S436, SN54S437 ... FK PACKAGE
SN74S436, SN74S437 ... FN PACKAGE
(TOP VIEW)

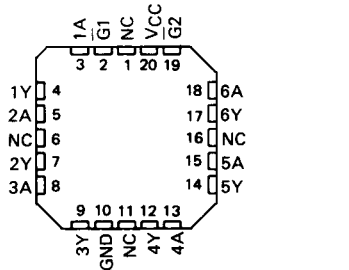

NC - No internal connection

description

The SN54S436, SN54S437, SN74S436 and SN74S437 are monolithic integrated TTL-to-MOS drivers and interface circuits. The p-n-p input transistors use minimum current allowing increased fan-out to these drivers. Schottky-clamped transistor logic permits high-speed operation, minimum propagation time.

A small series damping resistor has been included in the design of the 'S436 to eliminate undesired output transient overshoot. Either enable, \bar{G} , when high, sets the outputs to the high level for MOS RAM refresh applications.

FUNCTION TABLE

ENABLE INPUTS		INPUT	OUTPUT
$\bar{G}1$	$\bar{G}2$		
L	L	L	H
L	L	H	L
X	H	X	H
H	X	X	H

H = high level, L = low level, X = irrelevant

logic symbol

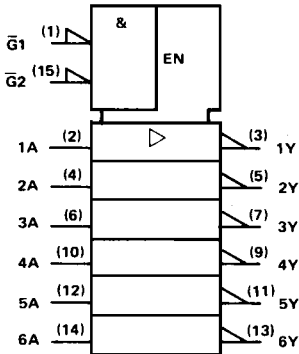

Pin numbers shown on logic notation are for D, J or N packages.

schematics of inputs and outputs

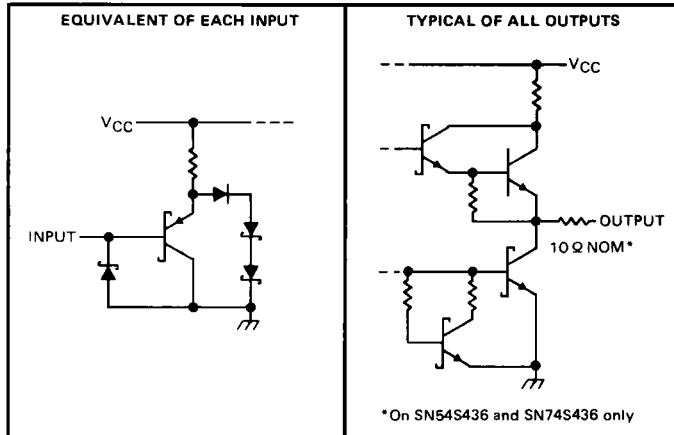

3

TTL DEVICES

PRODUCTION DATA

This document contains information current as of publication date. Products conform to specifications per the terms of Texas Instruments standard warranty. Production processing does not necessarily include testing of all parameters.

TEXAS
INSTRUMENTS

POST OFFICE BOX 225012 • DALLAS, TEXAS 75265

3-1093

TYPES SN54S436, SN54S437, SN74S436, SN74S437 LINE DRIVER/MEMORY DRIVER CIRCUITS

absolute maximum ratings over operating free-air temperature range (unless otherwise noted)

Supply voltage, V_{CC} (see Note 1)	7 V
Input voltage range	-1.5 V to 7 V
Continuous total dissipation at (or below) 25°C free-air temperature (see Note 2)	
J package	1375 mW
N package	1150 mW
W package	1000 mW
Operating free-air temperature range: SN54S436, SN54S437	-55°C to 125°C
SN74S436, SN74S437	0°C to 70°C
Storage temperature range	-65°C to 150°C

NOTES 1: All voltage values are with respect to network ground terminal.

2: For operation above 25°C free-air temperature, derate as follows: J package, 11.0 mW/°C, N package, 9.2 mW/°C, W package, 8.0 mW/°C.

recommended operating conditions

	SN54S*			SN74S*			UNIT		
	MIN	NOM	MAX	MIN	NOM	MAX			
V_{CC} Supply voltage	4.5	5	5.5	4.75	5	5.25	V		
V_{IH} High-level input voltage	2			2			V		
V_{IL} Low-level input voltage	0.8			0.8			V		
T_A Operating free-air temperature	-55			125			0	70	°C

electrical characteristics over recommended operating free-air temperature range (unless otherwise noted)

PARAMETER	TEST CONDITIONS	SN54LS165A			SN74LS165A			UNIT
		MIN	TYP†	MAX	MIN	TYP†	MAX	
V_{IK}	$V_{CC} = \text{MIN}$, $I_I = -18 \text{ mA}$	-0.75		-1.2	-0.75		-1.2	V
V_{OH}	$V_{CC} = \text{MIN}$, $I_{OH} = -10 \mu\text{A}$	3.4	4.3		3.5	4.3		V
	$V_{CC} = \text{MIN}$, $I_{OH} = -1 \text{ mA}$	2.4	3.5		2.6	3.5		
		2.5	3.5		2.7	3.5		
V_{OL}	$V_{CC} = \text{MIN}$, $I_{OL} = 10 \mu\text{A}$		0.25	0.4		0.25	0.35	V
	$V_{CC} = \text{MIN}$, $I_{OL} = 20 \text{ mA}$		0.6	1.1		0.6	1	
			0.4	0.5		0.4	0.5	
I_{OL}	$V_{CC} = \text{MIN}$, $V_O = 4.5 \text{ V}$, $V_I = 2 \text{ V}$ See Note 3		150	200		150	200	mA
I_{OS}^\ddagger	$V_{CC} = \text{MAX}$, $V_O = 0 \text{ V}$, See Note 3	-100	-250	-400	-100	-250	-400	mA
I_I	$V_{CC} = \text{MAX}$, $V_{IH} = 5.5 \text{ V}$			1			1	mA
I_{IH}	$V_{CC} = \text{MAX}$, $V_{IH} = 2.7 \text{ V}$		0.1	50		0.1	50	μA
I_{IL}	$V_{CC} = \text{MAX}$, $V_{IL} = 0.5 \text{ V}$		-100	-250		-100	-250	μA
I_{CC}	$V_{CC} = \text{MAX}$, G inputs at 0 V, All other inputs at 4.5 V		33	60		33	60	mA
	$V_{CC} = \text{MAX}$, All inputs at 0 V		14	20		14	20	

† All typical values are at $V_{CC} = 5 \text{ V}$, $T_A = 25^\circ\text{C}$.

‡ Not more than one output should be shorted at a time, and duration of the short-circuit should not exceed one second.

NOTE 3: When measuring output current on the SN54S437/SN74S437, a 10 Ω resistor should be placed in series with each output.

TYPES SN54S436, SN54S437, SN74S436, SN74S437 LINE DRIVER/MEMORY DRIVER CIRCUITS

switching characteristics, $V_{CC} = 5\text{ V}$, $T_A = 25^\circ\text{ C}$, see note 3

PARAMETER	TEST CONDITIONS	MIN	TYP	MAX	UNIT
t_{AHL}	Delay time from A high to Y starting low See Figure 1		4.5	7	ns
			12	16	
t_{ALY}	Delay time from A low to Y starting high See Figure 1		5	8	ns
			11	16	
t_{GHYH}	Delay time from G high to Y starting high See Figure 2		10	18	ns
t_{GLYL}	Delay time from G low to Y starting low See Figure 3		11	18	ns
t_{THL}	Transition time, high-to-low-level output See Figure 1		5	8	ns
			15	30	
t_{TLH}	Transition time, low-to-high-level output See Figure 1		6	9	ns
			15	30	

NOTE 3: When measuring switching times on the SN54S437/SN74S437, a 10 Ω resistor should be placed in series with each output.

PARAMETER MEASUREMENT INFORMATION

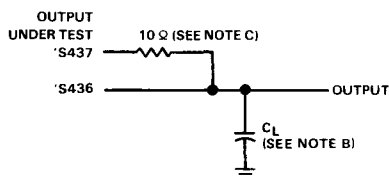

LOAD CIRCUIT

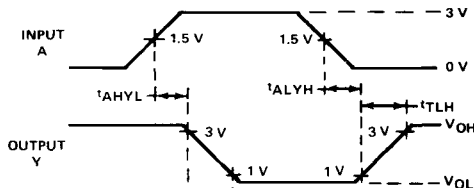

VOLTAGE WAVEFORMS

FIGURE 1

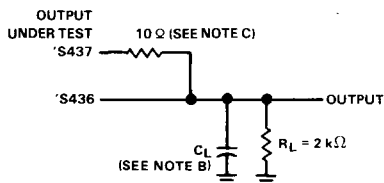

LOAD CIRCUIT

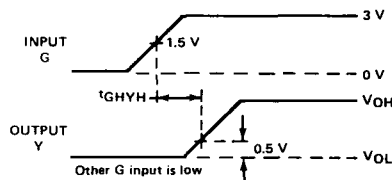

VOLTAGE WAVEFORMS

FIGURE 2

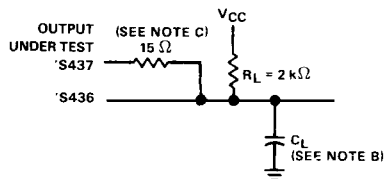

LOAD CIRCUIT

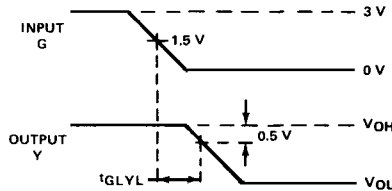

VOLTAGE WAVEFORMS

FIGURE 3

NOTES: A. Input pulses are supplied by a generator having the following characteristics: $PRR < 1\text{ MHz}$, $Z_{out} \approx 50\ \Omega$, $t_r < 5\text{ ns}$.

B. C_L includes probe and jig capacitance.

C. This 15- Ω resistor is required for testing the SN54S437/SN74S437, but it is internal to the SN54S436/SN74S436 and therefore an external resistor is not used for testing these devices.

3

TTL DEVICES

