

## 74F240 • 74F241 • 74F244 Octal Buffers/Line Drivers with 3-STATE Outputs

### General Description

The 'F240, 'F241 and 'F244 are octal buffers and line drivers designed to be employed as memory and address drivers, clock drivers and bus-oriented transmitters/receivers which provide improved PC and board density.

- Outputs sink 64 mA (48 mA mil)
- 12 mA source current
- Input clamp diodes limit high-speed termination effects
- Guaranteed 4000V minimum ESD protection

### Features

- 3-STATE outputs drive bus lines or buffer memory address registers

### Ordering Code:

Commercial	Military	Package Number	Package Description
74F240PC		N20A	20-Lead (0.300" Wide) Molded Dual-In-Line
	54F240DM (Note 2)	J20A	20-Lead Ceramic Dual-In-Line
74F240SC (Note 1)		M20B	20-Lead (0.300" Wide) Molded Small Outline, JEDEC
74F240SJ (Note 1)		M20D	20-Lead (0.300" Wide) Molded Small Outline, EIAJ
	54F240FM (Note 2)	W20A	20-Lead Cerpack
	54F240LM (Note 2)	E20A	20-Lead Ceramic Leadless Chip Carrier, Type C
74F241PC		N20A	20-Lead (0.300" Wide) Molded Dual-In-Line
	54F241DM (Note 2)	J20A	20-Lead Ceramic Dual-In-Line
74F241SC (Note 1)		M20B	20-Lead (0.300" Wide) Molded Small Outline, JEDEC
74F241SJ (Note 1)		M20D	20-Lead (0.300" Wide) Molded Small Outline, EIAJ
	54F241FM (Note 2)	W20A	20-Lead Cerpack
	54F241LM (Note 2)	E20A	20-Lead Ceramic Leadless Chip Carrier, Type C
74F244PC		N20A	20-Lead (0.300" Wide) Molded Dual-In-Line
	54F244DM (Note 2)	J20A	20-Lead Ceramic Dual-In-Line
74F244SC (Note 1)		M20B	20-Lead (0.300" Wide) Molded Small Outline, JEDEC
74F244SJ (Note 1)		M20D	20-Lead (0.300" Wide) Molded Small Outline, EIAJ
74F244MSA (Note 1)		MSA20	20-Lead Molded Shrink Small Outline, EIAJ Type II
	54F244FM (Note 2)	W20A	20-Lead Cerpack
	54F244LM (Note 2)	E20A	20-Lead Ceramic Leadless Chip Carrier, Type C

**Note 1:** Devices also available in 13" reel. Use Suffix = SCX, SJX and MSAX.

**Note 2:** Military grade device with environmental and burn-in processing. Use suffix = DMQB, FMQB and LMQB.

74F240 • 74F241 • 74F244 Octal Buffers/Line Drivers with 3-STATE Outputs

## Connection Diagrams

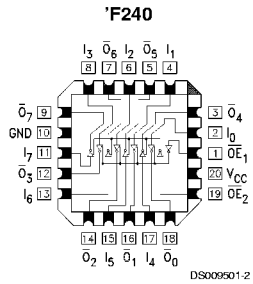

### Pin Assignment for LCC

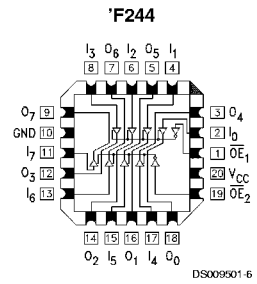
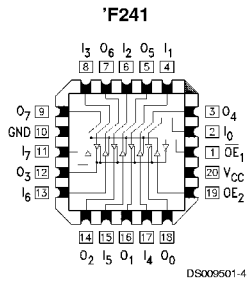

### Pin Assignment for DIP, SOIC, SSOP and Flatpak

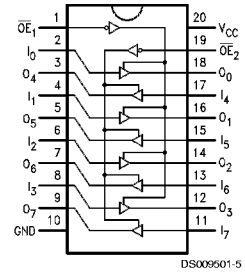
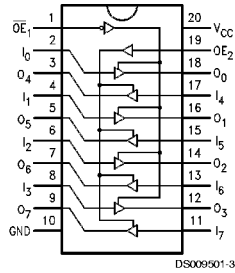
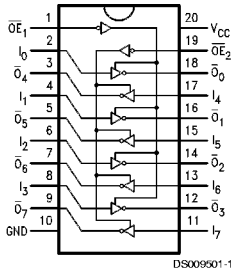

## Logic Symbols

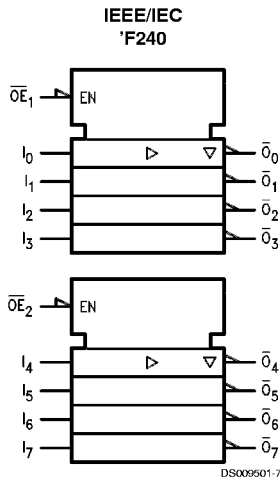

## Logic Symbols (Continued)

IEEE/IEC  
'F241

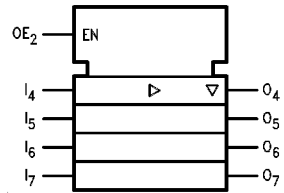
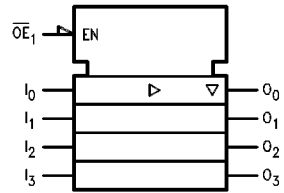

DS009501-8

IEEE/IEC  
'F244

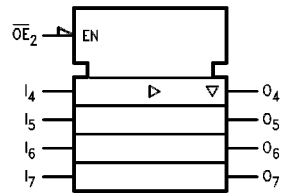
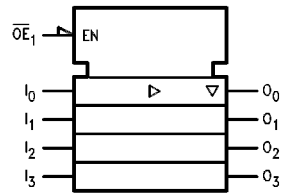

DS009501-9

## Unit Loading/Fan Out

Pin Names	Description	54F/74F	
		U.L. HIGH/LOW	Input $I_{IH}/I_{IL}$ Output $I_{OH}/I_{OL}$
$\overline{OE}_1, \overline{OE}_2$	3-STATE Output Enable Input (Active LOW)	1.0/1.667	20 $\mu A$ /-1 mA
$OE_2$	3-STATE Output Enable Input (Active HIGH)	1.0/1.667	20 $\mu A$ /-1 mA
$I_0-I_7$	Inputs ('F240)	1.0/1.667 (Note 3)	20 $\mu A$ /-1 mA
$I_0-I_7$	Inputs ('F241, 'F244)	1.0/2.667 (Note 3)	20 $\mu A$ /-1.6 mA
$\overline{O}_0-\overline{O}_7, O_0-O_7$	Outputs	600/106.6 (80)	-12 mA/64 mA (48 mA)

Note 3: Worst-case 'F240 enabled; 'F241, 'F244 disabled

## Truth Tables

### 'F240

$\overline{OE}_1$	$D_{1n}$	$O_{1n}$	$\overline{OE}_2$	$D_{2n}$	$O_{2n}$
H	X	Z	H	X	Z
L	H	L	L	H	L
L	L	H	L	L	H

### 'F241

$\overline{OE}_1$	$D_{1n}$	$O_{1n}$	$OE_2$	$D_{2n}$	$O_{2n}$
H	X	Z	L	X	Z
L	H	H	H	H	H
L	L	L	H	L	L

### 'F244

$\overline{OE}_1$	$D_{1n}$	$O_{1n}$	$\overline{OE}_2$	$D_{2n}$	$O_{2n}$
H	X	Z	H	X	Z
L	H	H	L	H	H
L	L	L	L	L	L

H = HIGH Voltage Level  
 L = LOW Voltage Level  
 X = Immaterial  
 Z = High Impedance

## Absolute Maximum Ratings (Note 4)

Storage Temperature	-65°C to +150°C
Ambient Temperature under Bias	-55°C to +125°C
Junction Temperature under Bias	-55°C to +175°C
Plastic	-55°C to +150°C
V <sub>CC</sub> Pin Potential to Ground Pin	-0.5V to +7.0V
Input Voltage (Note 5)	-0.5V to +7.0V
Input Current (Note 5)	-30 mA to +5.0 mA
Voltage Applied to Output in HIGH State (with V <sub>CC</sub> = 0V)	
Standard Output	-0.5V to V <sub>CC</sub>
3-STATE Output	-0.5V to +5.5V
Current Applied to Output in LOW State (Max)	twice the rated I <sub>OL</sub> (mA)

ESD Last Passing Voltage (Min)

4000V

## Recommended Operating Conditions

Free Air Ambient Temperature	
Military	-55°C to +125°C
Commercial	0°C to +70°C
Supply Voltage	
Military	+4.5V to +5.5V
Commercial	+4.5V to +5.5V

**Note 4:** Absolute maximum ratings are values beyond which the device may be damaged or have its useful life impaired. Functional operation under these conditions is not implied.

**Note 5:** Either voltage limit or current limit is sufficient to protect inputs.

## DC Electrical Characteristics

Symbol	Parameter	54F/74F			Units	V <sub>CC</sub>	Conditions
		Min	Typ	Max			
V <sub>IH</sub>	Input HIGH Voltage	2.0			V		Recognized as a HIGH Signal
V <sub>IL</sub>	Input LOW Voltage	0.8			V		Recognized as a LOW Signal
V <sub>CD</sub>	Input Clamp Diode Voltage	-1.2			V	Min	I <sub>IN</sub> = -18 mA
V <sub>OH</sub>	Output HIGH Voltage	54F 10% V <sub>CC</sub>	2.4		V	Min	I <sub>OH</sub> = -3 mA
		54F 10% V <sub>CC</sub>	2.0				I <sub>OH</sub> = -12 mA
		74F 10% V <sub>CC</sub>	2.4				I <sub>OH</sub> = -3 mA
		74F 10% V <sub>CC</sub>	2.0				I <sub>OH</sub> = -15 mA
		74F 5% V <sub>CC</sub>	2.7				I <sub>OH</sub> = -3 mA
V <sub>OL</sub>	Output LOW Voltage	54F 10% V <sub>CC</sub>	0.55		V	Min	I <sub>OL</sub> = 48 mA
		74F 10% V <sub>CC</sub>	0.55				I <sub>OL</sub> = 64 mA
I <sub>IH</sub>	Input HIGH Current	54F	20.0		μA	Max	V <sub>IN</sub> = 2.7V
		74F	5.0				
I <sub>BVI</sub>	Input HIGH Current Breakdown Test	54F	100		μA	Max	V <sub>IN</sub> = 7.0V
		74F	7.0				
I <sub>CEX</sub>	Output HIGH Leakage Current	54F	250		μA	Max	V <sub>OUT</sub> = V <sub>CC</sub>
		74F	50				
V <sub>ID</sub>	Input Leakage Test	74F	4.75		V	0.0	I <sub>ID</sub> = 1.9 μA All Other Pins Grounded
I <sub>OD</sub>	Output Leakage Circuit Current	74F	3.75		μA	0.0	V <sub>IOD</sub> = 150 mV All Other Pins Grounded
I <sub>IL</sub>	Input LOW Current		-1.0		mA	Max	V <sub>IN</sub> = 0.5V ( $\overline{OE}_1, \overline{OE}_2, OE_2, D_n$ ('F240))
			-1.6				V <sub>IN</sub> = 0.5V (D <sub>n</sub> ('F241, 'F244))
I <sub>OZH</sub>	Output Leakage Current		50		μA	Max	V <sub>OUT</sub> = 2.7V
I <sub>OZL</sub>	Output Leakage Current		-50		μA	Max	V <sub>OUT</sub> = 0.5V
I <sub>OS</sub>	Output Short-Circuit Current		-100	-225	mA	Max	V <sub>OUT</sub> = 0V
I <sub>ZZ</sub>	Bus Drainage Test		500		μA	0.0V	V <sub>OUT</sub> = 5.25V
I <sub>CCCH</sub>	Power Supply Current ('F240)		19	29	mA	Max	V <sub>O</sub> = HIGH
I <sub>CCCL</sub>	Power Supply Current ('F240)		50	75	mA	Max	V <sub>O</sub> = LOW
I <sub>CCZ</sub>	Power Supply Current ('F240)		42	63	mA	Max	V <sub>O</sub> = HIGH Z
I <sub>CCH</sub>	Power Supply Current ('F241, 'F244)		40	60	mA	Max	V <sub>O</sub> = HIGH
I <sub>CCL</sub>	Power Supply Current ('F241, 'F244)		60	90	mA	Max	V <sub>O</sub> = LOW

## DC Electrical Characteristics (Continued)

Symbol	Parameter	54F/74F			Units	V <sub>CC</sub>	Conditions
		Min	Typ	Max			
I <sub>CCZ</sub>	Power Supply Current ( <sup>1</sup> F241, <sup>1</sup> F244)	60	90		mA	Max	V <sub>O</sub> = HIGH Z

## AC Electrical Characteristics

Symbol	Parameter	74F			54F		74F		Units
		T <sub>A</sub> = +25°C V <sub>CC</sub> = +5.0V C <sub>L</sub> = 50 pF			T <sub>A</sub> , V <sub>CC</sub> = Mil C <sub>L</sub> = 50 pF		T <sub>A</sub> , V <sub>CC</sub> = Com C <sub>L</sub> = 50 pF		
		Min	Typ	Max	Min	Max	Min	Max	
t <sub>PLH</sub>	Propagation Delay	3.0	5.1	7.0	3.0	9.0	3.0	8.0	ns
t <sub>PHL</sub>	Data to Output ( <sup>1</sup> F240)	2.0	3.5	4.7	2.0	6.0	2.0	5.7	
t <sub>PZH</sub>	Output Enable Time ( <sup>1</sup> F240)	2.0	3.5	4.7	2.0	6.5	2.0	5.7	ns
t <sub>PZL</sub>	Output Disable Time ( <sup>1</sup> F240)	4.0	6.9	9.0	4.0	10.5	4.0	10.0	
t <sub>PHZ</sub>	Output Disable Time ( <sup>1</sup> F240)	2.0	4.0	5.3	2.0	6.5	2.0	6.3	ns
t <sub>PLZ</sub>	Output Disable Time ( <sup>1</sup> F240)	2.0	6.0	8.0	2.0	12.5	2.0	9.5	
t <sub>PLH</sub>	Propagation Delay	2.5	4.0	5.2	2.0	6.5	2.5	6.2	ns
t <sub>PHL</sub>	Data to Output ( <sup>1</sup> F241, <sup>1</sup> F244)	2.5	4.0	5.2	2.0	7.0	2.5	6.5	
t <sub>PZH</sub>	Output Enable Time	2.0	4.3	5.7	2.0	7.0	2.0	6.7	ns
t <sub>PZL</sub>	( <sup>1</sup> F241, <sup>1</sup> F244)	2.0	5.4	7.0	2.0	8.5	2.0	8.0	
t <sub>PHZ</sub>	Output Disable Time	2.0	4.5	6.0	2.0	7.0	2.0	7.0	ns
t <sub>PLZ</sub>	( <sup>1</sup> F241, <sup>1</sup> F244)	2.0	4.5	6.0	2.0	7.5	2.0	7.0	

## Ordering Information

The device number is used to form part of a simplified purchasing code where the package type and temperature range are defined as follows:

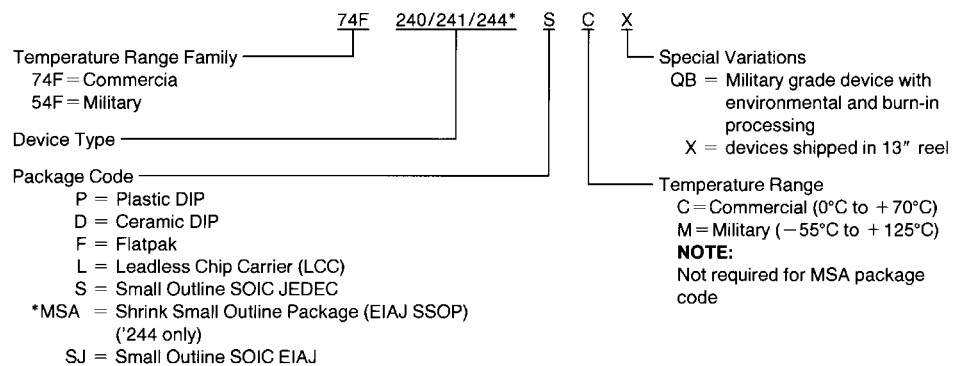

DS009501-10

**Physical Dimensions** inches (millimeters) unless otherwise noted

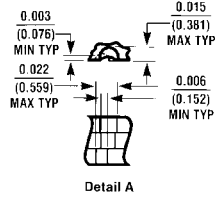
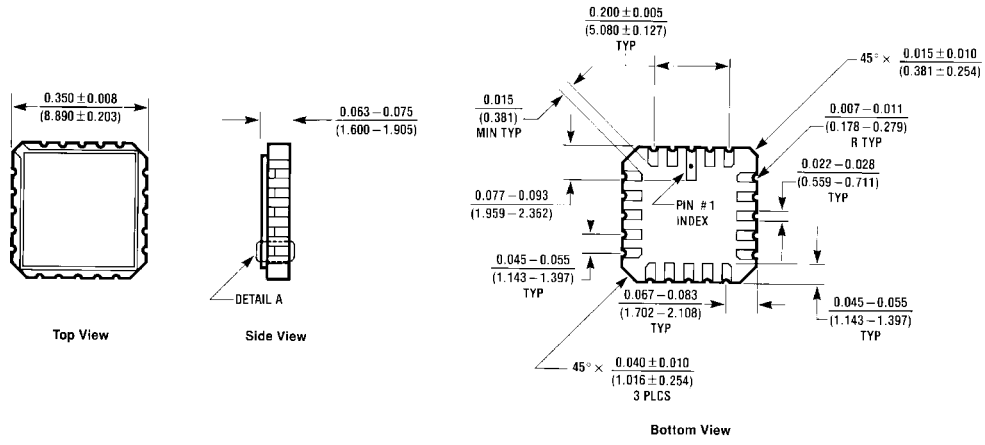

E20A (REV 0)

**20-Lead Ceramic Leadless Chip Carrier (L)**  
**Package Number E20A**

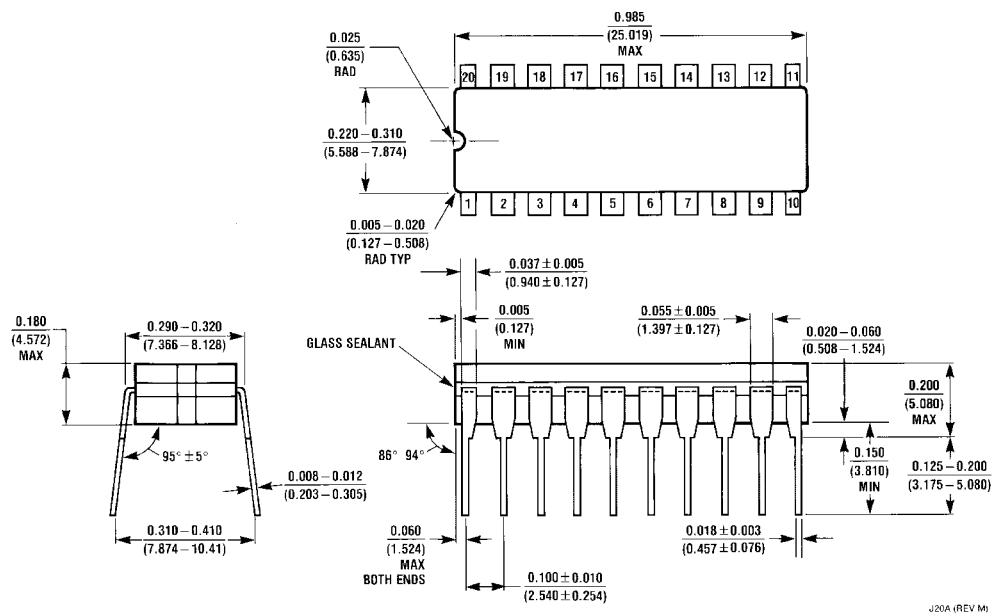

J20A (REV M)

**20-Lead Ceramic Dual-In-Line Package (D)**  
**Package Number J20A**

**Physical Dimensions** inches (millimeters) unless otherwise noted (Continued)

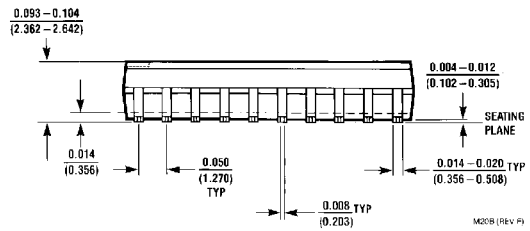
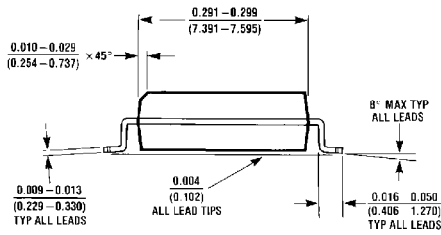
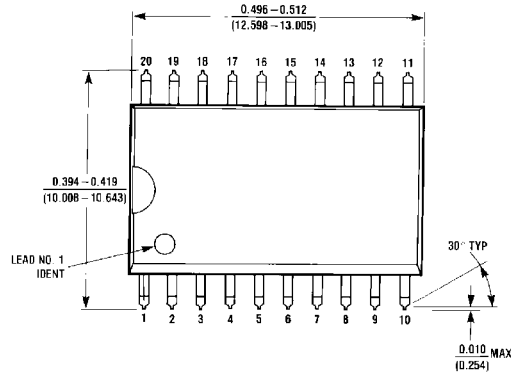

**20-Lead (0.300" Wide) Molded Small Outline Package, JEDEC (S)  
Package Number M20B**

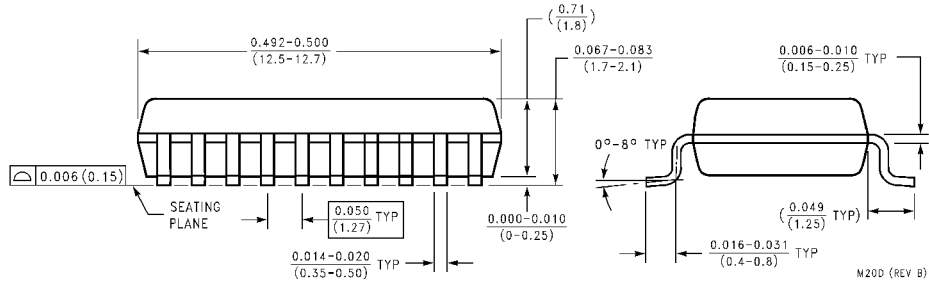
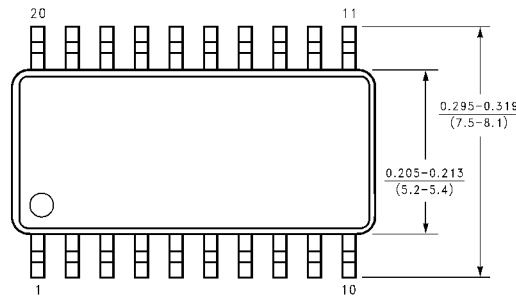

**20-Lead (0.300" Wide) Molded Small Outline Package, EIAJ (SJ)  
Package Number M20D**



**Physical Dimensions** inches (millimeters) unless otherwise noted (Continued)

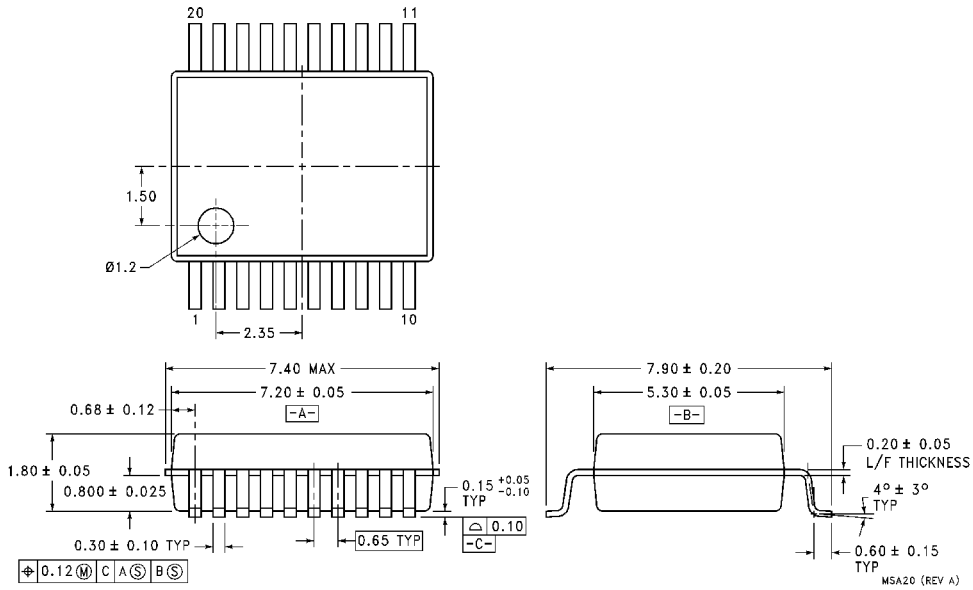

**20-Lead Molded Shrink Small Outline, EIAJ Type II (MSA)  
Package Number MSA20**

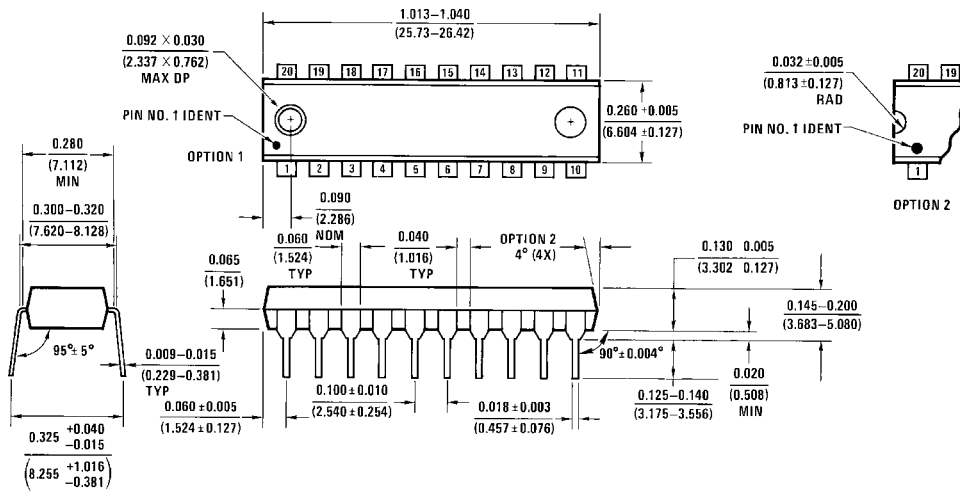

**20-Lead (0.300" Wide) Molded Dual-In-Line Package (P)  
Package Number N20A**

**Physical Dimensions** inches (millimeters) unless otherwise noted (Continued)

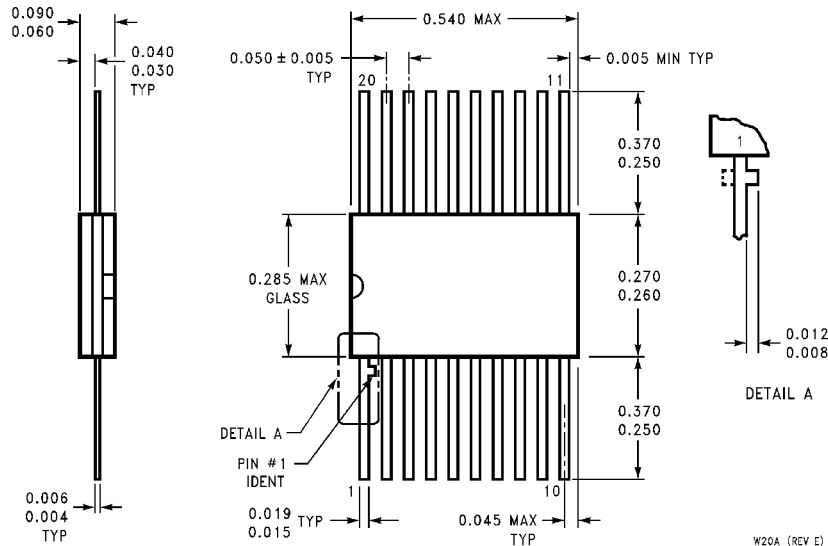

**20-Lead Ceramic Flatpak (F)  
Package Number W20A**

**LIFE SUPPORT POLICY**

FAIRCHILD'S PRODUCTS ARE NOT AUTHORIZED FOR USE AS CRITICAL COMPONENTS IN LIFE SUPPORT DEVICES OR SYSTEMS WITHOUT THE EXPRESS WRITTEN APPROVAL OF THE PRESIDENT OF FAIRCHILD SEMICONDUCTOR CORPORATION. As used herein:

1. Life support devices or systems are devices or systems which, (a) are intended for surgical implant into the body, or (b) support or sustain life, and (c) whose failure to perform when properly used in accordance with instructions for use provided in the labeling, can be reasonably expected to result in a significant injury to the user.
2. A critical component in any component of a life support device or system whose failure to perform can be reasonably expected to cause the failure of the life support device or system, or to affect its safety or effectiveness.

Fairchild Semiconductor Corporation  
Americas  
Customer Response Center  
Tel: 1-888-522-5372

Fairchild Semiconductor Europe  
Fax: +49 (0) 1 80-530 85 86  
Email: europe.support@nsc.com  
Deutsch Tel: +49 (0) 8 141-35-0  
English Tel: +44 (0) 1 793-85-68-56  
Italy Tel: +39 (0) 2 57 5631

Fairchild Semiconductor Hong Kong Ltd.  
13th Floor, Straight Block,  
Ocean Centre, 5 Canton Rd.  
Tsimshatsui, Kowloon  
Hong Kong  
Tel: +852 2737-7200  
Fax: +852 2314-0061

National Semiconductor Japan Ltd.  
Tel: 81-3-5620-6175  
Fax: 81-3-5620-6179

www.fairchildsemi.com