

SN54HCT240, SN54HCT241, SN74HCT240, SN74HCT241 OCTAL BUFFERS AND LINE DRIVERS CMOS LOGIC WITH 3-STATE OUTPUTS

D2804, MARCH 1984—REVISED JUNE 1989

- Inputs are TTL-Voltage Compatible
- 3-State Outputs Drive Bus Lines or Buffer Memory Address Registers
- High-Current Outputs Drive Up to 15 LSTTL Loads
- Package Options Include Plastic "Small Outline" Packages, Ceramic Chip Carriers, and Standard Plastic and Ceramic 300-mil DIPs
- Dependable Texas Instruments Quality and Reliability

description

These octal buffers and line drivers are designed specifically to improve both the performance and density of three-state memory address drivers, clock drivers, and bus-oriented receivers and transmitters. The designer has a choice of selected combinations of inverting and noninverting outputs, symmetrical \bar{G} (active-low output control) inputs, and complementary G and \bar{G} inputs. These devices feature high fan-out.

The SN54HCT' family is characterized for operation over the full military temperature range of -55°C to 125°C . The SN74HCT' family is characterized for operation from -40°C to 85°C .

SN54HCT' . . . J PACKAGE
SN74HCT' . . . DW OR N PACKAGE
(TOP VIEW)

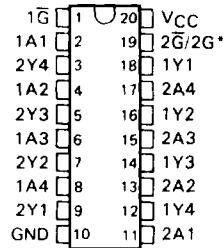

SN54HCT' . . . FK PACKAGE
(TOP VIEW)

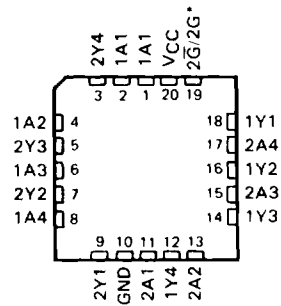

* $2\bar{G}$ for 'HCT240, or 2G for 'HCT241

logic symbols†

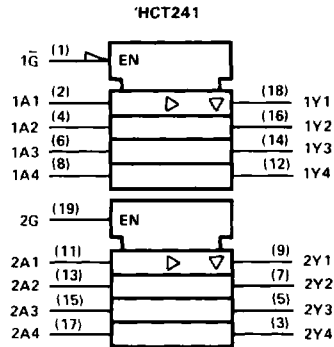
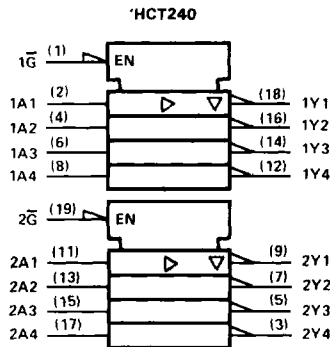

† These symbols are in accordance with ANSI/IEEE Std 91-1984 and IEC Publication 617-12. Pin numbers shown are for DW, J, and N packages.

PRODUCTION DATA documents contain information current as of publication date. Products conform to specifications per the terms of Texas Instruments standard warranty. Production processing does not necessarily include testing of all parameters.



POST OFFICE BOX 655012 • DALLAS, TEXAS 75265

Copyright © 1989, Texas Instruments Incorporated

2-317

SN54HCT240, SN54HCT241, SN74HCT240, SN74HCT241 OCTAL BUFFERS AND LINE DRIVERS WITH 3-STATE OUTPUTS

FUNCTION TABLES

'HCT240
(EACH BUFFER)

INPUTS		OUTPUT
G	A	Y
L	H	L
L	L	H
H	X	Z

'HCT241
(EACH BUFFER IN FIRST SET)

INPUTS		OUTPUT
1G	1A	1Y
L	H	H
L	L	L
H	X	Z

'HCT241
(EACH BUFFER IN SECOND SET)

INPUTS		OUTPUT
2G	2A	2Y
H	H	H
H	L	L
L	X	Z

2

logic diagram (positive logic)

HCMOS Devices

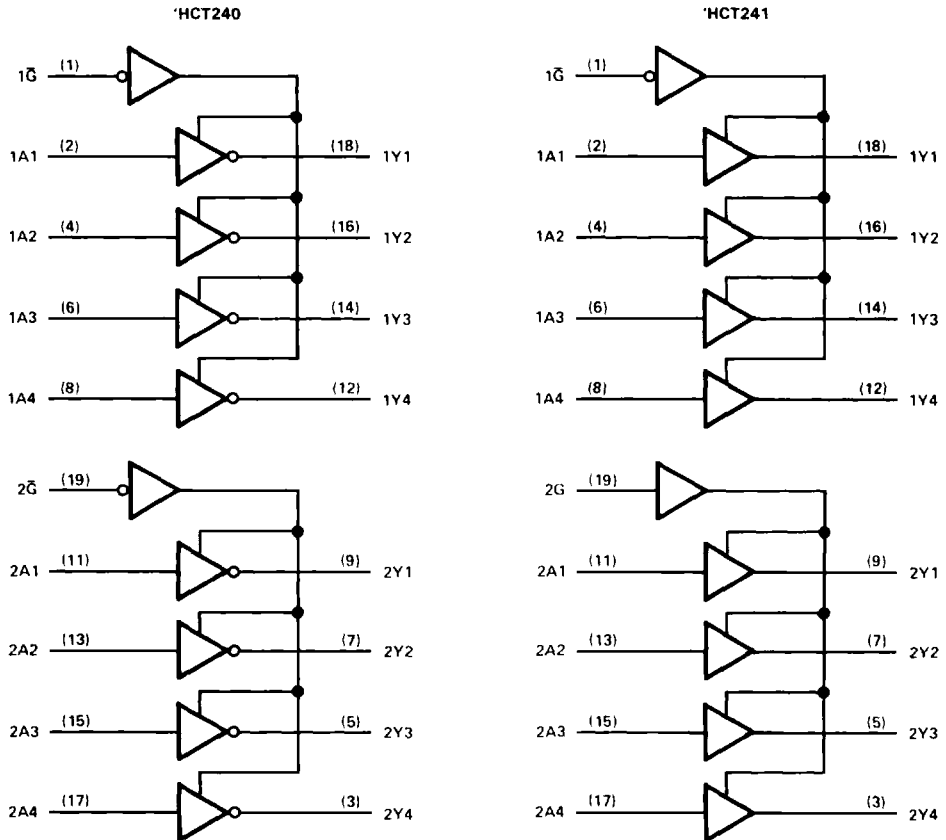

Pin numbers shown are for DW, J, and N packages.

SN54HCT240, SN54HCT241, SN74HCT240, SN74HCT241 OCTAL BUFFERS AND LINE DRIVERS WITH 3-STATE OUTPUTS

absolute maximum ratings over operating free-air temperature range†

Supply voltage, V_{CC}	-0.5 V to 7 V
Input clamp current, I_{IK} ($V_I < 0$ or $V_I > V_{CC}$)	± 20 mA
Output clamp current, I_{OK} ($V_O < 0$ or $V_O > V_{CC}$)	± 20 mA
Continuous output current, I_O ($V_O = 0$ to V_{CC})	± 35 mA
Continuous current through V_{CC} or GND pins	± 70 mA
Lead temperature 1,6 mm (1/16 in) from case for 60 s: FK or J package	300°C
Lead temperature 1,6 mm (1/16 in) from case for 10 s: DW or N package	260°C
Storage temperature range	-65°C to 150°C

† Stresses beyond those listed under "absolute maximum ratings" may cause permanent damage to the device. These are stress ratings only, and functional operation of the device at these or any other conditions beyond those indicated under "recommended operating conditions" is not implied. Exposure to absolute-maximum-rated conditions for extended periods may affect device reliability.

recommended operating conditions

		SN54HCT240 SN54HCT241			SN74HCT240 SN74HCT241			UNIT
		MIN	NOM	MAX	MIN	NOM	MAX	
V_{CC}	Supply voltage	4.5	5	5.5	4.5	5	5.5	V
V_{IH}	High-level input voltage	$V_{CC} = 4.5$ V to 5.5 V		2	2			V
V_{IL}	Low-level input voltage	$V_{CC} = 4.5$ V to 5.5 V		0	0.8			V
V_I	Input voltage	0	V_{CC}		0	V_{CC}		V
V_O	Output voltage	0	V_{CC}		0	V_{CC}		V
t_t	Input transition (rise and fall) times	0	500		0	500		ns
T_A	Operating free-air temperature	-55	125		-40	85		°C

electrical characteristics over recommended operating free-air temperature range (unless otherwise noted)

PARAMETER	TEST CONDITIONS	V_{CC}	$T_A = 25^\circ\text{C}$			SN54HCT240 SN54HCT241		SN74HCT240 SN74HCT241		UNIT
			MIN	TYP	MAX	MIN	MAX	MIN	MAX	
V_{OH}	$V_I = V_{IH}$ or V_{IL} , $I_{OH} = -20$ μA	4.5 V	4.4	4.499		4.4		4.4	V	
	$V_I = V_{IH}$ or V_{IL} , $I_{OH} = -6$ mA	4.5 V	3.98	4.30		3.7		3.84		
V_{OL}	$V_I = V_{IH}$ or V_{IL} , $I_{OL} = 20$ μA	4.5 V		0.001	0.1		0.1		0.1	
	$V_I = V_{IH}$ or V_{IL} , $I_{OL} = 6$ mA	4.5 V		0.17	0.26		0.4		0.33	
I_I	$V_I = V_{CC}$ or 0	5.5 V		± 0.1	± 100		± 1000		± 1000	nA
I_{OZ}	$V_O = V_{CC}$ or 0, $V_I = V_{IH}$ or V_{IL}	5.5 V		± 0.01	± 0.5		± 10		± 5	μA
I_{CC}	$V_I = V_{CC}$ or 0, $I_O = 0$	5.5 V			8		160		80	μA
ΔI_{CC}^\ddagger	One input at 0.5 V or 2.4 V Other inputs at 0 V or V_{CC}	5.5 V		1.4	2.4		3.0		2.9	mA
C_i		4.5 to 5.5 V		3	10		10		10	pF

‡ This is the increase in supply current for each input that is at one of the specified TTL voltage levels rather than 0 V or V_{CC} .

SN54HCT240, SN54HCT241, SN74HCT240, SN74HCT241
OCTAL BUFFERS AND LINE DRIVERS WITH 3-STATE OUTPUTS

switching characteristics over recommended operating free-air temperature range (unless otherwise noted), $C_L = 50$ pF (see Note 1)

PARAMETER	FROM (INPUT)	TO (OUTPUT)	V_{CC}	$T_A = 25^\circ\text{C}$			SN54HCT240 SN54HCT241		SN74HCT240 SN74HCT241		UNIT
				MIN	TYP	MAX	MIN	MAX	MIN	MAX	
t_{pd}	A	Y	4.5 V	13	25		37		32	ns	
			5.5 V	12	23		33		29		
t_{en}	G or \bar{G}	Y	4.5 V	21	35		53		44	ns	
			5.5 V	19	32		48		40		
t_{dis}	G or \bar{G}	Y	4.5 V	19	35		53		44	ns	
			5.5 V	18	32		48		40		
t_t		Y	4.5 V	8	12		18		15	ns	
			5.5 V	7	11		16		14		

C_{pd}	Power dissipation capacitance per buffer	No load, $T_A = 25^\circ\text{C}$	40 pF typ
----------	--	-----------------------------------	-----------

switching characteristics over recommended operating free-air temperature range (unless otherwise noted), $C_L = 150$ pF (see Note 1)

PARAMETER	FROM (INPUT)	TO (OUTPUT)	V_{CC}	$T_A = 25^\circ\text{C}$			SN54HCT240 SN54HCT241		SN74HCT240 SN74HCT241		UNIT
				MIN	TYP	MAX	MIN	MAX	MIN	MAX	
t_{pd}	A	Y	4.5 V	20	42		63		53	ns	
			5.5 V	19	38		56		48		
t_{en}	G or \bar{G}	Y	4.5 V	25	52		79		65	ns	
			5.5 V	22	47		71		59		
t_t		Y	4.5 V	17	42		63		53	ns	
			5.5 V	14	38		57		48		

NOTE 1: Load circuit and voltage waveforms are shown in Section 1.