

Quad buffer (3-State)

54F125

FEATURES

- High impedance NPN base inputs for reduced loading (20µA in High and Low states)

ORDERING INFORMATION

DESCRIPTION	ORDER CODE	PACKAGE DESIGNATOR*
14-Pin Ceramic DIP	54F125/BCA	GDIP1-T14
14-Pin Ceramic Flat Pack	54F125/BDA	GDIP1-F14
20-Pin Ceramic LLCC	54F125/B2A	CQCC2-N20

* MIL-STD 1835 or Appendix A of 1995 Military Data Handbook

FUNCTION TABLE

INPUTS		OUTPUT
C	A	Y
L	L	L
L	H	H
H	X	(Z)

H = High voltage level
 L = Low voltage level
 X = Don't care
 Z = High Impedance

INPUT AND OUTPUT LOADING AND FAN-OUT TABLE

PINS	DESCRIPTION	54F(U.L.) HIGH/LOW	LOAD VALUE HIGH/LOW
1A - 4A	Data inputs	1.0/0.033	20µA/20µA
$\overline{1C}$ - $\overline{4C}$	3-State output enable input	1.0/0.033	20µA/20µA
1Y - 4Y	Data outputs	600/80	12mA/48mA

NOTE: One (1.0) FAST Unit Load is defined as: 20µA in the High state and 0.6mA in the Low state.

ABSOLUTE MAXIMUM RATINGS

(Operation beyond the limits set forth in this table may impair the useful life of the device. Unless otherwise noted these limits are over the operating free-air temperature range.)

SYMBOL	PARAMETER	RATING	UNIT
V _{CC}	Supply voltage range	-0.5 to +7.0	V
V _I	Input voltage range	-0.5 to +7.0	V
I _I	Input current range	-30 to +5	mA
V _O	Voltage applied to output in High output state range	-0.5 to V _{CC}	V
I _O	Current applied to output in Low output state	96	mA
T _{STG}	Storage temperature range	-65 to +150	°C

PIN CONFIGURATION

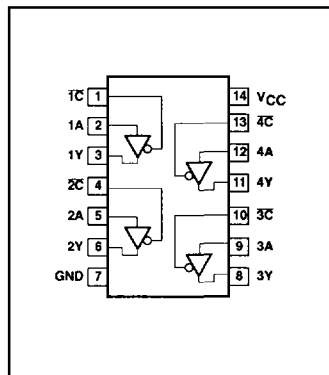

LOGIC SYMBOL

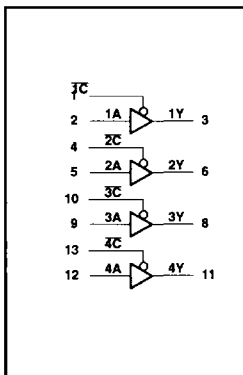

LLCC LEAD CONFIGURATION

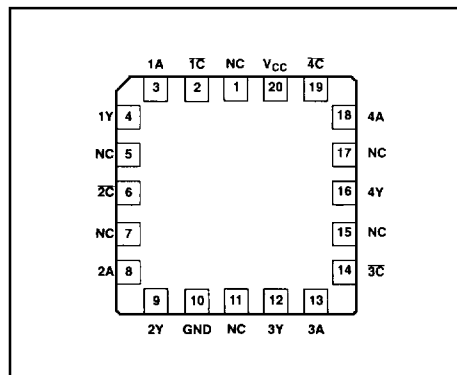

Quad buffer (3-State)

54F125

RECOMMENDED OPERATING CONDITIONS

SYMBOL	PARAMETER	LIMITS			UNIT
		MIN	NOM	MAX	
V _{CC}	Supply voltage	4.5	5.0	5.5	V
V _{IH}	High-level input voltage	2.0			V
V _{IL}	Low-level input voltage			0.8	V
I _{IK}	Input clamp current			-18	mA
I _{OH}	High-level output current			-12	mA
I _{OL}	Low-level output current			48	mA
T _{amb}	Operating free-air temperature range	-55		+125	°C

DC ELECTRICAL CHARACTERISTICS

(Over recommended operating free-air temperature range unless otherwise noted.)

SYMBOL	PARAMETER	TEST CONDITIONS ¹	LIMITS			UNIT	
			MIN	TYP ²	MAX		
V _{OH}	High-level output voltage	V _{CC} = MIN, V _{IL} = MAX, V _{IH} = MIN	I _{OH} = -3mA	2.4		V	
			I _{OH} = MAX	2.0		V	
V _{OL}	Low-level output voltage	V _{CC} = MIN, V _{IL} = MAX, V _{IH} = MIN	I _{OL} = 48mA		.35 .50	V	
V _{IK}	Input clamp voltage	V _{CC} = MIN, I _I = I _{IK}		-0.73	-1.2	V	
I _{IH2}	Input current at maximum input voltage	V _{CC} = 0.0V, V _I = 7.0V			100	μA	
I _{IH1}	High-level input current	V _{CC} = MAX, V _I = 2.7V			20	μA	
I _{IL}	Low-level input current	V _{CC} = MAX, V _I = 0.5V			-20	μA	
I _{OZH}	Off-state output current, High-level voltage applied	V _{CC} = MAX, V _{IH} = MIN, V _O = 2.7V		2	50	μA	
I _{OZL}	Off-state output current, Low-level voltage applied	V _{CC} = MAX, V _{IH} = MIN, V _O = 0.5V		-2	-50	μA	
I _{OS}	Short-circuit output current ³	V _{CC} = MAX		-100	-150 -225	mA	
I _{CC}	Supply Current ⁴ (total)	V _{CC} = MAX	n \bar{C} = GND, nA = 4.5V		17	24	mA
			n \bar{C} = nA = GND		28	40	mA
			n \bar{C} = nA = 4.5V		25	35	mA

AC ELECTRICAL CHARACTERISTICS

SYMBOL	PARAMETER	TEST CONDITIONS	LIMITS					UNIT
			T _{amb} = +25°C, V _{CC} = +5.0V C _L = 50pF R _L = 500Ω			T _{amb} = -55°C to +125°C V _{CC} = +5.0V ± 10% C _L = 50pF, R _L = 500Ω		
			MIN	TYPE	MAX	MIN	MAX	
t _{PLH} t _{PHL}	Propagation delay nA to nY	Waveform 1	2.0 3.0	4.0 5.5	6.0 7.5	2.0 3.0	7.0 8.5	ns
t _{PZH} t _{PZL}	Output enable time to High and Low level	Waveform 2 Waveform 3	3.5 4.0	5.5 6.0	7.5 8.0	3.5 4.0	9.0 9.5	ns
t _{PHZ} t _{PLZ}	Output disable time From High and Low level	Waveform 2 Waveform 3	1.5 1.5	3.5 3.5	5.0 5.5	1.5 1.5	6.5 7.5	ns

NOTES:

- For conditions shown as MIN or MAX, use the appropriate value specified under recommended operating conditions for the applicable type and function table for operating mode.
- All typical values are at V_{CC} = 5V, T_{amb} = 25°C.
- Not more than one output should be shorted at a time and the duration of the short circuit should not exceed one second.
- I_{CC} is measured with outputs open.

Quad buffer (3-State)

54F125

AC WAVEFORMS

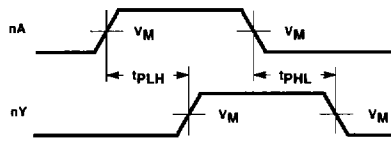

Waveform 1. Propagation Delay For Input to Output

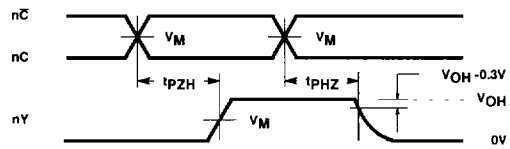

Waveform 2. 3-State Output Enable Time to High Level and Output Disable Time from High Level

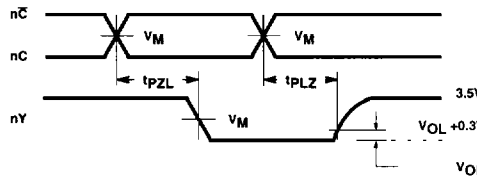

Waveform 3. 3-State Output Enable Time to Low Level and Output Disable Time from Low Level

NOTE: For all waveforms, $V_M = 1.5V$

TEST CIRCUIT AND WAVEFORM

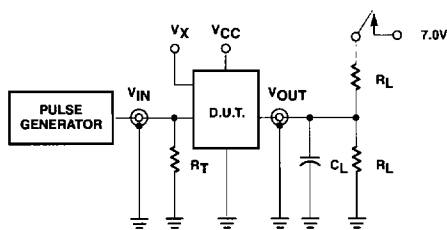

Test Circuit for 3-State Outputs and Open Collector Outputs

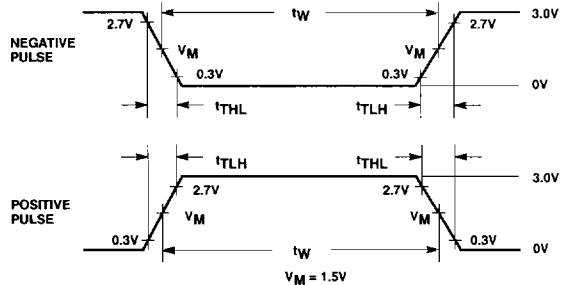

Input Pulse Definitions

SWITCH POSITION

TEST	SWITCH
t_{PLZ}	closed
t_{PZL}	closed
All other	open

INPUT PULSE CHARACTERISTICS				
Family	Rep. Rate	Pulse Width	t_{TLH}	t_{THL}
54F	1MHz	500ns	$\leq 2.5ns$	$\leq 2.5ns$

DEFINITIONS:

- R_L = Load Resistor; see AC Characteristics for value.
- C_L = Load capacitance includes jig and probe capacitance; see AC Characteristics for value.
- R_T = Termination resistance should be equal to Z_{OUT} of pulse generators.
- V_X = Unlocked pins must be held at: $\leq 0.8V$; $\geq 2.7V$ or open per Function Table.