

MM54HC253/MM74HC253

Dual 4-Channel TRI-STATE® Multiplexer

General Description

The MM54HC253/MM74HC253 utilizes advanced silicon-gate CMOS technology to achieve the low power consumption and high noise immunity of standard CMOS integrated circuits, along with the capability to drive 10 LS-TTL loads. The large output drive and TRI-STATE features of this device make it ideally suited for interfacing with bus lines in bus organized systems. When the output control input is taken high, the multiplexer outputs are sent into a high impedance state.

When the output control is held low, the associated multiplexer chooses the correct output channel for the given input signals determined by the select A and B inputs.

The 54HC/74HC logic family is functionally and pinout compatible with the standard 54LS/74LS logic family. All inputs are protected from damage due to static discharge by internal diode clamps to V_{CC} and ground.

Features

- Typical propagation delay: 24 ns
- Wide power supply range: 2V–6V
- Low quiescent current: 80 μ A maximum (74HC Series)
- Low input current: 1 μ A maximum
- Fanout of 10 LS-TTL loads

Connection Diagram

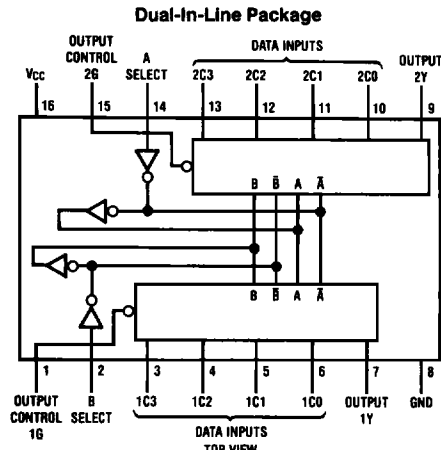

TL/F/5108-1

Order Number **MM54HC253*** or **MM74HC253***

*Please look into Section 8, Appendix D for availability of various package types.

Truth Table

Select Inputs		Data Inputs				Output Control	Output
B	A	C0	C1	C2	C3	G	Y
X	X	X	X	X	X	H	Z
L	L	L	X	X	X	L	L
L	L	H	X	X	X	L	H
L	H	X	L	X	X	L	L
L	H	X	H	X	X	L	H
H	L	X	X	L	X	L	L
H	L	X	X	H	X	L	H
H	H	X	X	X	L	L	L
H	H	X	X	X	H	L	H

Select inputs A and B are common to both sections.

H = high level, L = low level, X = irrelevant, Z = high impedance (off).

Absolute Maximum Ratings (Notes 1 & 2)

If Military/Aerospace specified devices are required, contact the National Semiconductor Sales Office/Distributors for availability and specifications.

Supply Voltage (V_{CC})	-0.5 to +7.0V
DC Input Voltage (V_{IN})	-1.5 to V_{CC} + 1.5V
DC Output Voltage (V_{OUT})	-0.5 to V_{CC} + 0.5V
Clamp Diode Current (I_{IK}, I_{OK})	± 20 mA
DC Output Current, per pin (I_{OUT})	± 25 mA
DC V_{CC} or GND Current, per pin (I_{CC})	± 50 mA
Storage Temperature Range (T_{STG})	-65°C to +150°C
Power Dissipation (P_D)	
(Note 3)	600 mW
S.O. Package only	500 mW
Lead Temperature (T_L)	
(Soldering 10 seconds)	260°C

Operating Conditions

	Min	Max	Units
Supply Voltage (V_{CC})	2	6	V
DC Input or Output Voltage (V_{IN}, V_{OUT})	0	V_{CC}	V
Operating Temp. Range (T_A)			
MM74HC	-40	+85	°C
MM54HC	-55	+125	°C
Input Rise or Fall Times (t_r, t_f)			
$V_{CC} = 2.0V$		1000	ns
$V_{CC} = 4.5V$		500	ns
$V_{CC} = 6.0V$		400	ns

DC Electrical Characteristics (Note 4)

Symbol	Parameter	Conditions	V_{CC}	$T_A = 25^\circ C$		74HC $T_A = -40$ to $85^\circ C$		54HC $T_A = -55$ to $125^\circ C$		Units
				Typ	Guaranteed Limits					
V_{IH}	Minimum High Level Input Voltage		2.0V		1.5	1.5	1.5	1.5	V	
			4.5V		3.15	3.15	3.15	V		
			6.0V		4.2	4.2	4.2	V		
V_{IL}	Maximum Low Level Input Voltage**		2.0V		0.5	0.5	0.5	0.5	V	
			4.5V		1.35	1.35	1.35	V		
			6.0V		1.8	1.8	1.8	V		
V_{OH}	Minimum High Level Output Voltage	$V_{IN} = V_{IH}$ or V_{IL} $ I_{OUT} \leq 20 \mu A$	2.0V	2.0	1.9	1.9	1.9	V		
			4.5V	4.5	4.4	4.4	4.4	V		
			6.0V	6.0	5.9	5.9	5.9	V		
		$V_{IN} = V_{IH}$ or V_{IL} $ I_{OUT} \leq 4.0$ mA $ I_{OUT} \leq 5.2$ mA	4.5V	4.2	3.98	3.84	3.7	V		
			6.0V	5.7	5.48	5.34	5.2	V		
V_{OL}	Maximum Low Level Output Voltage	$V_{IN} = V_{IH}$ or V_{IL} $ I_{OUT} \leq 20 \mu A$	2.0V	0	0.1	0.1	0.1	V		
			4.5V	0	0.1	0.1	0.1	V		
			6.0V	0	0.1	0.1	0.1	V		
		$V_{IN} = V_{IH}$ or V_{IL} $ I_{OUT} \leq 4.0$ mA $ I_{OUT} \leq 5.2$ mA	4.5V	0.2	0.26	0.33	0.4	V		
			6.0V	0.2	0.26	0.33	0.4	V		
I_{IN}	Maximum Input Current	$V_{IN} = V_{CC}$ or GND	6.0V		± 0.1	± 1.0	± 1.0	μA		
I_{OZ}	Maximum TRI-STATE Output Leakage Current	Strobe = V_{CC} $V_{OUT} = V_{CC}$ or GND	6.0V		± 0.5	± 5.0	± 10	μA		
I_{CC}	Maximum Quiescent Supply Current	$V_{IN} = V_{CC}$ or GND $I_{OUT} = 0 \mu A$	6.0V		8.0	80	160	μA		

Note 1: Absolute Maximum Ratings are those values beyond which damage to the device may occur.

Note 2: Unless otherwise specified all voltages are referenced to ground.

Note 3: Power Dissipation temperature derating — plastic "N" package: -12 mW/°C from 65°C to 85°C; ceramic "J" package: -12 mW/°C from 100°C to 125°C.

Note 4: For a power supply of 5V ± 10% the worst case output voltages (V_{OH} , and V_{OL}) occur for HC at 4.5V. Thus the 4.5V values should be used when designing with this supply. Worst case V_{IH} and V_{IL} occur at $V_{CC} = 5.5V$ and 4.5V respectively. (The V_{IH} value at 5.5V is 3.85V.) The worst case leakage current (I_{IN} , I_{CC} , and I_{OZ}) occur for CMOS at the higher voltage and so the 6.0V values should be used.

** V_{IL} limits are currently tested at 20% of V_{CC} . The above V_{IL} specification (30% of V_{CC}) will be implemented no later than Q1, CY'89.

AC Electrical Characteristics $V_{CC}=5V, T_A=25^{\circ}C, t_r=t_f=6\text{ ns}, C_L=15\text{ pF}$

Symbol	Parameter	Conditions	Typ	Guaranteed Limit	Units
t_{PHL}, t_{PLH}	Maximum Propagation Delay, Select A or B to Y		24	30	ns
t_{PHL}, t_{PLH}	Maximum Propagation Delay, any Data to Y		18	23	ns
t_{PZH}, t_{PZL}	Maximum Output Enable Time Y Output to a Logic Level	$R_L=1\text{ k}\Omega$	13	18	ns
t_{PHZ}, t_{PLZ}	Maximum Output Disable Time Y Output to High Impedance State	$R_L=1\text{ k}\Omega$	18	27	ns

AC Electrical Characteristics $C_L=50\text{ pF}, t_r=t_f=6\text{ ns}$ (unless otherwise specified)

Symbol	Parameter	Conditions	V_{CC}	$T_A=25^{\circ}C$				Units	
				Guaranteed Limits					
				74HC		54HC			
				$T_A=-40\text{ to }85^{\circ}C$		$T_A=-55\text{ to }125^{\circ}C$			
				Typ	Guaranteed Limits				
t_{PHL}, t_{PLH}	Maximum Propagation Delay, Select A or B to Y		2.0V	131	158	198	237	ns	
			4.5V	29	35	44	53	ns	
			6.0V	24	30	38	45	ns	
t_{PHL}, t_{PLH}	Maximum Propagation Delay, any Data to Y		2.0V	99	126	158	189	ns	
			4.5V	22	28	35	42	ns	
			6.0V	19	23	29	35	ns	
t_{PZH}, t_{PZL}	Maximum Output Enable Time	$R_L=1\text{ k}\Omega$	2.0V	63	90	113	135	ns	
			4.5V	14	20	25	30	ns	
			6.0V	12	17	21	26	ns	
t_{PHZ}, t_{PLZ}	Maximum Output Disable Time	$R_L=1\text{ k}\Omega$	2.0V	90	135	169	203	ns	
			4.5V	20	30	38	45	ns	
			6.0V	17	25	31	38	ns	
t_{THL}, t_{TLH}	Maximum Output Rise and Fall Time		2.0V	30	75	95	110	ns	
			4.5V	8	15	19	22	ns	
			6.0V	7	13	16	19	ns	
C_{IN}	Maximum Input Capacitance			5	10	10	10	pF	
C_{PD}	Power Dissipation Capacitance (Note 5)	(per package) Outputs Enabled		90				pF	
			Outputs Disabled	25				pF	

Note 5: C_{PD} determines the no load dynamic power consumption, $P_D=C_{PD}V_{CC}^2 f+I_{CC}V_{CC}$, and the no load dynamic current consumption, $I_S=C_{PD}V_{CC} f+I_{CC}$.

Logic Diagram

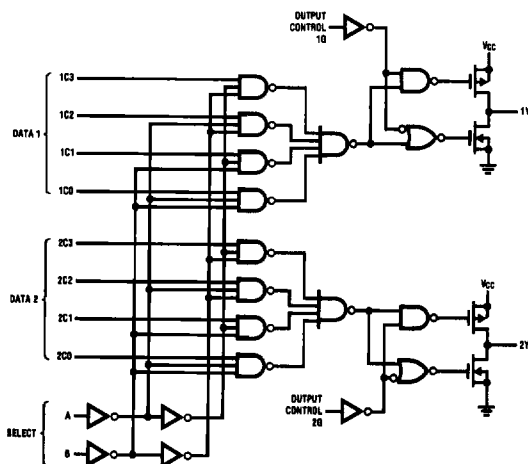

TL/F/5106-2