

54ACT16475, 74ACT16475 18-BIT REGISTERED TRANSCIEVERS WITH 3-STATE OUTPUTS

SCAS198A - OCTOBER 1980 - REVISED APRIL 1996

- Members of the Texas Instruments *Widebus™* Family
- Inputs Are TTL-Voltage Compatible
- 3-State Inverting Outputs
- Flow-Through Architecture Optimizes PCB Layout
- Distributed V_{CC} and GND Pin Configuration Minimizes High-Speed Switching Noise
- EPIC™ (Enhanced-Performance Implanted CMOS) 1-μm Process
- 500-mA Typical Latch-Up Immunity at 125°C
- Packaged in Plastic 300-mil Shrink Small-Outline (DL) Packages Using 25-mil Center-to-Center Pin Spacings and 380-mil Fine-Pitch Ceramic Flat (WD) Packages Using 25-mil Center-to-Center Pin Spacings

description

The 'ACT16475 are 18-bit registered transceivers that contain two sets of D-type flip-flops for temporary storage of data flowing in either direction. They can be used as two 9-bit transceivers or one 18-bit transceiver. Separate clock (CLKAB and CLKBA) and output-enable (\overline{OEAB} or \overline{OEBA}) inputs are provided for each register to permit independent control in either direction of data flow.

Data at the A inputs meeting the setup time requirements is transferred to the B outputs on the positive-going edge of CLKAB. With \overline{OEAB} low, the 3-state B outputs are enabled and reflect the inverted A data. Data flow from B to A is similar but requires the use of the CLKBA and \overline{OEBA} inputs.

The 74ACT16475 is packaged in TI's shrink small-outline package, which provides twice the I/O pin count and functionality of standard small-outline packages in the same printed-circuit-board area.

The 54ACT16475 is characterized for operation over the full military temperature range of -55°C to 125°C. The 74ACT16475 is characterized for operation from -40°C to 85°C.

54ACT16475 . . . WD PACKAGE
74ACT16475 . . . DL PACKAGE
(TOP VIEW)

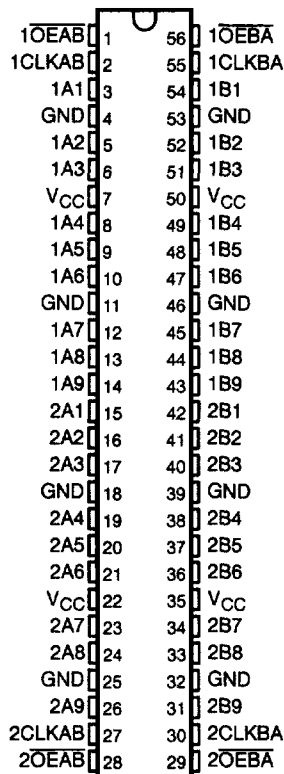

EPIC and Widebus are trademarks of Texas Instruments Incorporated.

UNLESS OTHERWISE NOTED this document contains PRODUCTION DATA information current as of publication date. Products conform to specifications per the terms of Texas Instruments standard warranty. Production processing does not necessarily include testing of all parameters.



POST OFFICE BOX 655303 • DALLAS, TEXAS 75265

Copyright © 1996, Texas Instruments Incorporated

54ACT16475, 74ACT16475
18-BIT REGISTERED TRANSCEIVERS
WITH 3-STATE OUTPUTS

SCAS198A – OCTOBER 1990 – REVISED APRIL 1996

FUNCTION TABLE†

INPUTS			OUTPUT
OEAB	CLKAB	A	B
H	X	X	Z
L	L	X	B ₀ ‡
L	↑	L	H
L	↑	H	L

† A-to-B data flow is shown; B-to-A flow is similar but uses CLKBA and OEBA.

‡ Output level before the indicated steady-state input conditions were established

logic symbols§

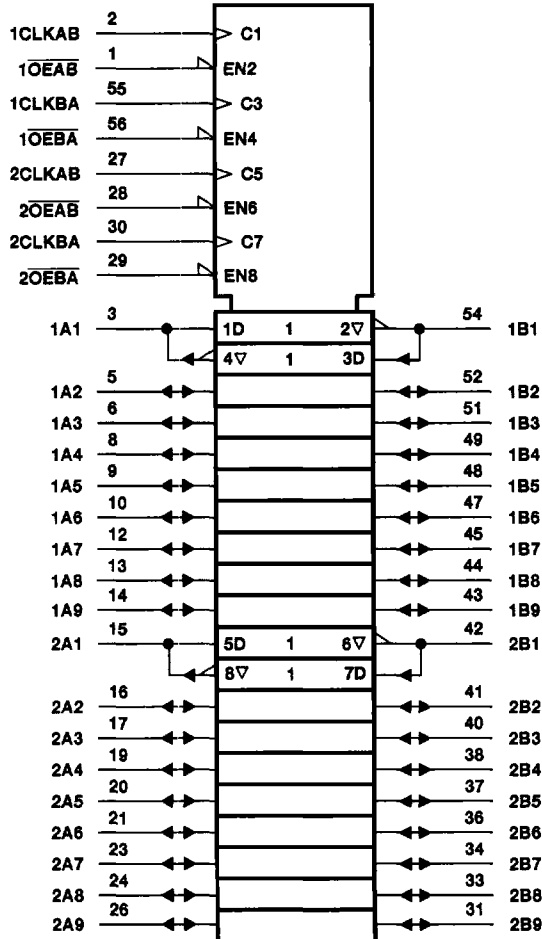

§ This symbol is in accordance with ANSI/IEEE Std 91-1984 and IEC Publication 617-12.



54ACT16475, 74ACT16475
18-BIT REGISTERED TRANSCEIVERS
WITH 3-STATE OUTPUTS

SCAS198A - OCTOBER 1990 - REVISED APRIL 1996

logic diagram (positive logic)

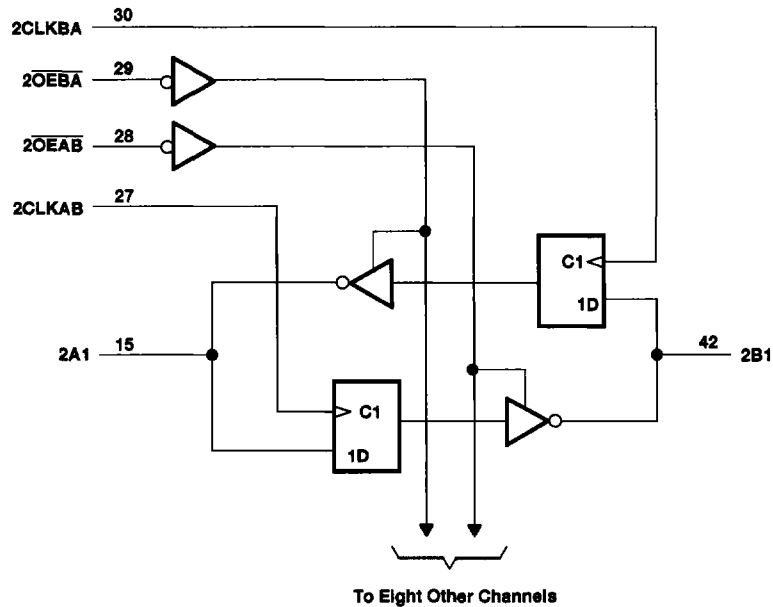
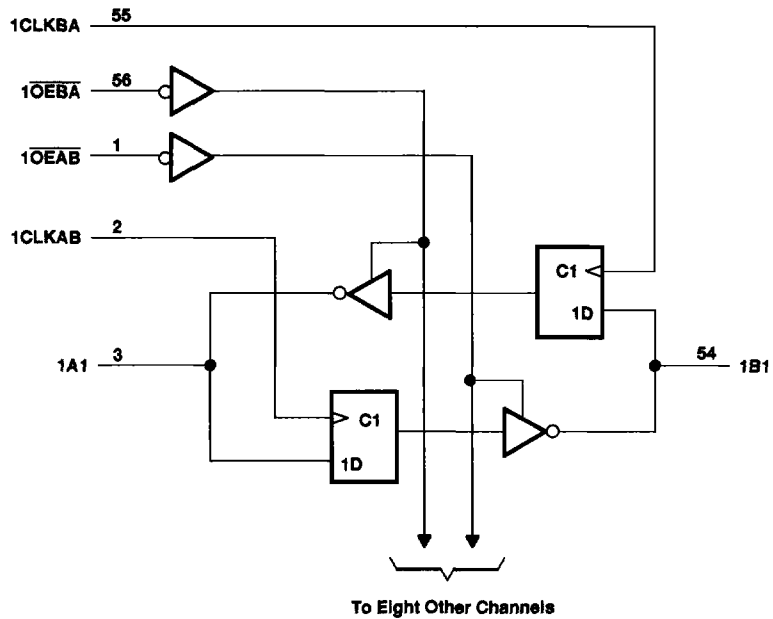

54ACT16475, 74ACT16475 18-BIT REGISTERED TRANSCEIVERS WITH 3-STATE OUTPUTS

SCAS198A - OCTOBER 1990 - REVISED APRIL 1996

absolute maximum ratings over operating free-air temperature range (unless otherwise noted)†

Supply voltage range, V_{CC}	-0.5 V to 7 V
Input voltage range, V_I (see Note 1)	-0.5 V to $V_{CC} + 0.5$ V
Input voltage range, V_O (see Note 1)	-0.5 V to $V_{CC} + 0.5$ V
Input clamp current, I_{IK} ($V_I < 0$ or $V_I > V_{CC}$)	± 20 mA
Output clamp current, I_{OK} ($V_O < 0$ or $V_O > V_{CC}$)	± 50 mA
Continuous output current, I_O ($V_O = 0$ to V_{CC})	± 50 mA
Continuous current through V_{CC} or GND	± 450 mA
Maximum power package dissipation at $T_A = 55^\circ\text{C}$ (in still air) (see Note 2): DL package	1.4 W
Storage temperature range, T_{stg}	-65°C to 150°C

† Stresses beyond those listed under "absolute maximum ratings" may cause permanent damage to the device. These are stress ratings only, and functional operation of the device at these or any other conditions beyond those indicated under "recommended operating conditions" is not implied. Exposure to absolute-maximum-rated conditions for extended periods may affect device reliability.

- NOTES: 1. The input and output voltage ratings may be exceeded if the input and output current ratings are observed.
2. The maximum package power dissipation is calculated using a junction temperature of 150°C and a board trace length of 750 mils.

recommended operating conditions (see Note 2)

	54ACT16475			74ACT16475			UNIT
	MIN	NOM	MAX	MIN	NOM	MAX	
V_{CC} Supply voltage	4.5	5	5.5	4.5	5	5.5	V
V_{IH} High-level input voltage	2			2			V
V_{IL} Low-level input voltage			0.8			0.8	V
V_I Input voltage	0		V_{CC}	0		V_{CC}	V
V_O Output voltage	0		V_{CC}	0		V_{CC}	V
I_{OH} High-level output current			-24			-24	mA
I_{OL} Low-level output current			24			24	mA
$\Delta V/\Delta v$ Input transition rise or fall rate			10			10	ns/V
T_A Operating free-air temperature	-55		125	-40		85	$^\circ\text{C}$

NOTE 3: Unused pins (input or I/O) must be held high or low to prevent them from floating.

54ACT16475, 74ACT16475
18-BIT REGISTERED TRANSCIEVERS
WITH 3-STATE OUTPUTS

SCAS198A - OCTOBER 1990 - REVISED APRIL 1996

electrical characteristics over recommended operating free-air temperature range (unless otherwise noted)

PARAMETER	TEST CONDITIONS	V _{CC}	T _A = 25°C			54ACT16475		74ACT16475		UNIT
			MIN	TYP	MAX	MIN	MAX	MIN	MAX	
V _{OH}	I _{OH} = -50 μA	4.5 V	4.4			4.4		4.4	V	
		5.5 V	5.4			5.4		5.4		
	I _{OH} = -24 mA	4.5 V	3.94			3.8		3.8		
		5.5 V	4.94			4.8		4.8		
	I _{OH} = -75 mA†	5.5 V				3.85		3.85		
V _{OL}	I _{OL} = 50 μA	4.5 V			0.1			0.1	V	
		5.5 V			0.1			0.1		
	I _{OL} = 24 mA	4.5 V			0.36		0.44	0.44		
		5.5 V			0.36		0.44	0.44		
		I _{OL} = 75 mA†	5.5 V				1.65			1.65
I _I	Control Inputs	V _I = V _{CC} or GND	5.5 V			±0.1		±1	μA	
I _{OZ} ‡	A or B ports	V _O = V _{CC} or GND	5.5 V			±0.5		±5	μA	
I _{CC}		V _I = V _{CC} or GND, I _O = 0	5.5 V			8		80	μA	
ΔI _{CC} §		One input at 3.4 V, Other inputs at V _{CC} or GND	5.5 V			0.9		1	mA	
C _i	Control inputs	V _I = V _{CC} or GND	5 V		4.5				pF	
C _{io}	A or B ports	V _O = V _{CC} or GND	5 V		12				pF	

† Not more than one output should be tested at a time, and the duration of the test should not exceed 10 ms.

‡ For I/O ports, the parameter I_{OZ} includes the input leakage current.

§ This is the increase in supply current for each input that is at one of the specified TTL voltage levels rather than 0 V or V_{CC}.

**timing requirements over recommended operating free-air temperature range,
V_{CC} = 5 V ± 0.5 V (unless otherwise noted) (see Figure 1)**

			T _A = 25°C		54ACT16475		74ACT16475		UNIT
			MIN	MAX	MIN	MAX	MIN	MAX	
f _{clock}	Clock frequency		0	75	0	75	0	75	MHz
t _w	Pulse duration	CLK high or low	6.5		6.5		6.5		ns
t _{su}	Setup time	Data before CLK↑	5.5				5.5		ns
t _h	Hold time	Data after CLK↑	1.5				1.5		ns

**switching characteristics over recommended operating free-air temperature range,
V_{CC} = 5 V ± 0.5 V (unless otherwise noted) (see Figure 1)**

PARAMETER	FROM (INPUT)	TO (OUTPUT)	T _A = 25°C			54ACT16475		74ACT16475		UNIT
			MIN	TYP	MAX	MIN	MAX	MIN	MAX	
f _{max}			75			75		75	MHz	
t _{PLH}	CLKAB or CLKBA	B or A	3.8	7.9	11.1	3.8	12.5	3.8	12.5	ns
t _{PHL}			4.2	8.1	11.4	4.2	12.6	4.2	12.6	
t _{PZH}	OEAB or OEBA	B or A	2.8	7.3	11.4	2.9	12.8	2.8	12.8	ns
t _{PZL}			3.4	7.4	13.1	3.4	14.8	3.4	14.8	
t _{PHZ}	OEAB or OEBA	B or A	5.2	6.5	9.8	5.2	10.5	5.2	10.5	ns
t _{PLZ}			4.5	6.6	9.1	4.5	9.8	4.5	9.8	

PRODUCT PREVIEW information concerns products in the formative or design phase of development. Characteristic data and other specifications are design goals. Texas Instruments reserves the right to change or discontinue these products without notice.



54ACT16475, 74ACT16475
18-BIT REGISTERED TRANSCEIVERS
WITH 3-STATE OUTPUTS

SCAS198A - OCTOBER 1990 - REVISED APRIL 1996

operating characteristics, $V_{CC} = 5\text{ V}$, $T_A = 25^\circ\text{C}$

PARAMETER		TEST CONDITIONS		TYP	UNIT
C_{pd}	Power dissipation capacitance per transceiver	Outputs enabled	$C_L = 60\text{ pF}$, $f = 1\text{ MHz}$	27	pF
		Outputs disabled		9	

PARAMETER MEASUREMENT INFORMATION

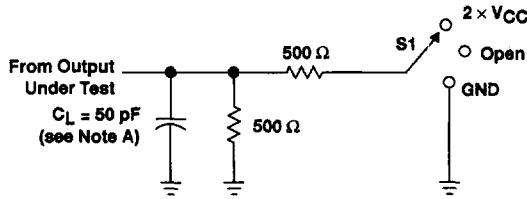

LOAD CIRCUIT

TEST	S1
t_{PLH}/t_{PHL}	Open
t_{PLZ}/t_{PZL}	$2 \times V_{CC}$
t_{PHZ}/t_{PZH}	GND

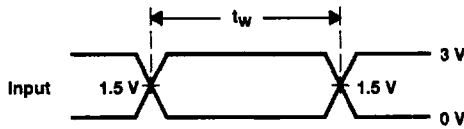

VOLTAGE WAVEFORMS

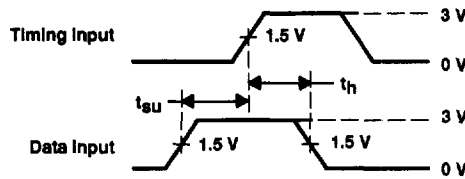

VOLTAGE WAVEFORMS

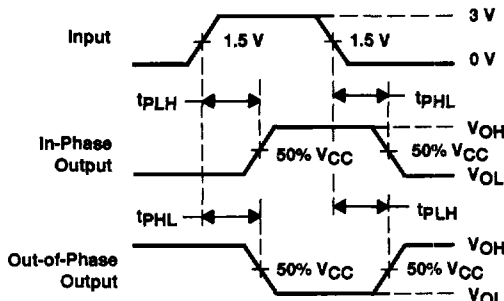

VOLTAGE WAVEFORMS

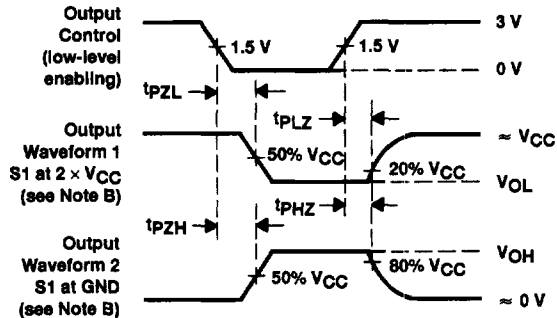

VOLTAGE WAVEFORMS

- NOTES: A. C_L includes probe and jig capacitance.
 B. Waveform 1 is for an output with internal conditions such that the output is low except when disabled by the output control. Waveform 2 is for an output with internal conditions such that the output is high except when disabled by the output control.
 C. All input pulses are supplied by generators having the following characteristics: $PRR \leq 1\text{ MHz}$, $Z_O = 50\ \Omega$, $t_r = 3\text{ ns}$, $t_f = 3\text{ ns}$.
 D. The outputs are measured one at a time with one input transition per measurement.

Figure 1. Load Circuit and Voltage Waveforms