

54/74ETL16245 16-Bit Data Transceiver with Incident Wave Switching

General Description

The 54/74ETL16245 contains sixteen non-inverting bidirectional buffers with TRI-STATE® outputs designed with incident wave switching, live insertion support and enhanced noise margin for TTL backplane applications.

Both the A and B ports include a bus hold circuit to latch the output to the value last forced on that pin.

The B port of this device includes 25Ω series output resistors, which minimize undershoot and ringing.

Features

- Supports the VME64 ETL specification
- Functionally and pin compatible with industry standard TTL 16245 SSOP pinout

- Improved TTL-compatible input threshold range
- High drive TTL-compatible outputs ($I_{OH} = -60 \text{ mA}$, $I_{OL} = 90 \text{ mA}$)
- Supports 25Ω incident wave switching on the A port
- BiCMOS design significantly reduces power dissipation.
- Distributed V_{CC} and GND pin configuration minimizes high-speed switching noise
- 25Ω series-dampening resistor on B-port
- Available in 48-pin SSOP and ceramic flatpak
- Guaranteed output skew
- Guaranteed simultaneous switching noise level and dynamic threshold performance
- Guaranteed latchup protection

Logic Symbol

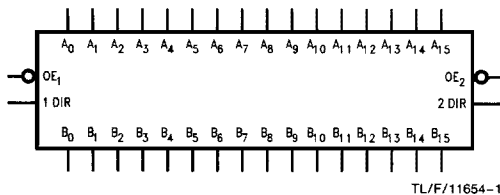

Connection Diagram

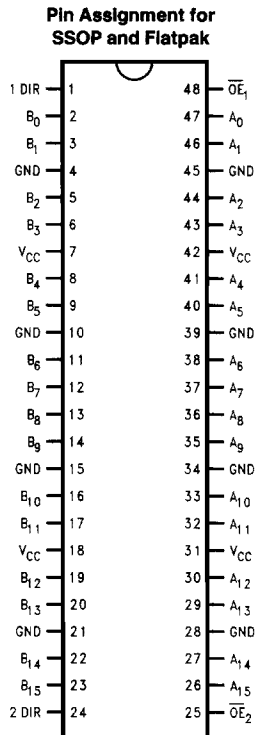

Pin Description

Pin Names	Description
DIR	Transmit/Receive Input
\overline{OE}	Output Enable Input (Active LOW)
A_n	Backplane Bus Data
B_n	Local Bus Data

Functional Description

The device uses byte-wide Direction (DIR) control and Output Enable (\overline{OE}) controls. The DIR inputs determine the direction of data flow through the device. The \overline{OE} inputs disable the A and the B ports.

The part contains active circuitry which keeps all outputs disabled when V_{CC} is less than 2.2V to aid in live insertion applications.

Logic Diagrams (Positive Logic)

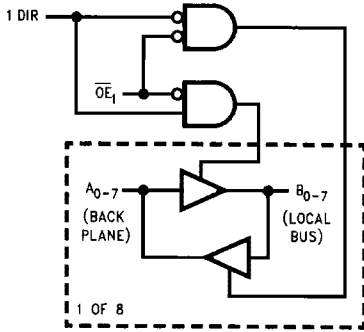

TL/F/11654-3

Truth Table (Each 8-bit Section)

Inputs		Operation
\overline{OE}	DIR	
L	L	A Data to B Bus
L	H	B Data to A Bus
H	X	Isolation

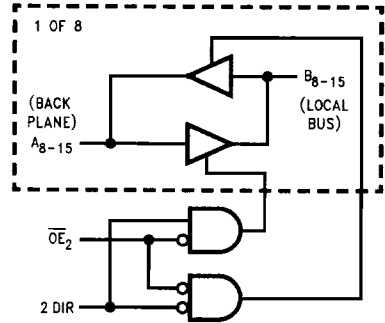

TL/F/11654-4

ETL's Improved Noise Immunity

TTL input thresholds are typically determined by temperature-dependent junction voltages which result in worst case input thresholds between 0.8V and 2.0V. By contrast, ETL provides greater noise immunity because its input thresholds are determined by ECL or BTL. ETL's worst case input thresholds, between 1.4V and 1.6V, are compensated for temperature, voltage and process variations.

Incident Wave Switching

When TTL logic is used to drive fully loaded backplanes, the combination of low backplane bus characteristic impedance, wide TTL input threshold range and limited TTL drive generally require multiple waveform reflections before a valid signal can be received across the backplane. The VME International Trade Association (VITA) defined ETL to provide incident wave switching which increases the data transfer rate of a VME backplane and extends the life of VME applications. TTL compatibility with existing VME backplanes and modules was maintained.

Improved Input Threshold Characteristics of ETL

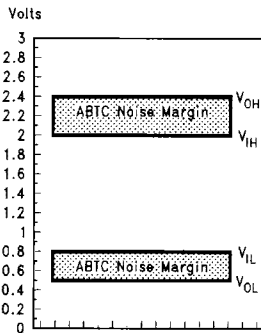

ABTC Worst Case $V_{OUT}-V_{IN}$

TL/F/11654-5

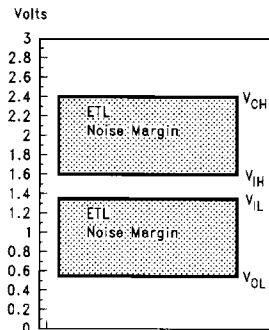

ETL Worst Case $V_{OUT}-V_{IN}$

TL/F/11654-6

Incident Wave Switching (Continued)

To demonstrate the incident wave switching capability, consider a VME application. A VME bus must be terminated to +2.94V with 190Ω at each end of its 21 card backplane. The surge impedance presented by a fully loaded VME backplane is approximately 25Ω. If the output voltage/current of an ABTC driver is plotted with this load, the inter-

section at 1.2V for a falling edge and at 1.6V for a rising edge does not reach the worst case input threshold of a second ABTC circuit. This is shown in the two figures below. However, an ETL driver located at one end of the backplane is able to provide incident wave switching because it has a higher drive and a tighter input threshold.

Estimated ETL/ABTC Initial Falling Edge Step

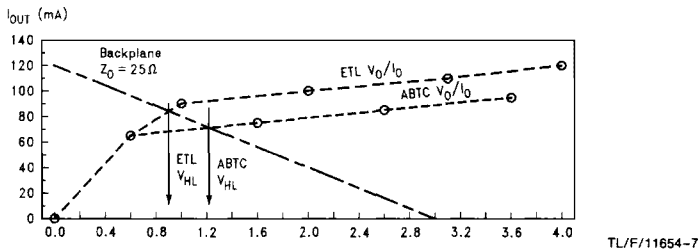

Because ETL has a much more precise input threshold region, an ETL receiver will interpret its predicted falling input of 0.85V as a logic ZERO and the initial rising edge of 1.9V as a logic ONE. This comparison is for the case of a 25Ω surge impedance backplane driven from one end.

Estimated ETL/ABTC Initial Rising Edge Step

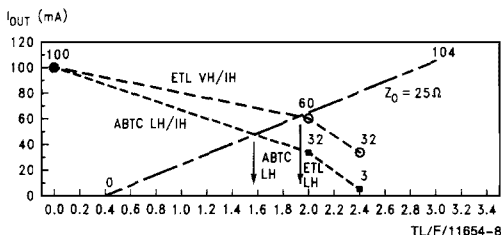

The resulting ABTC and ETL waveform predictions and their input thresholds are compared below. This shows how ETL can achieve backplane speeds not always possible with conventional TTL compatible logic families.

Comparing the Incident Wave Switching of ETL with ABTC

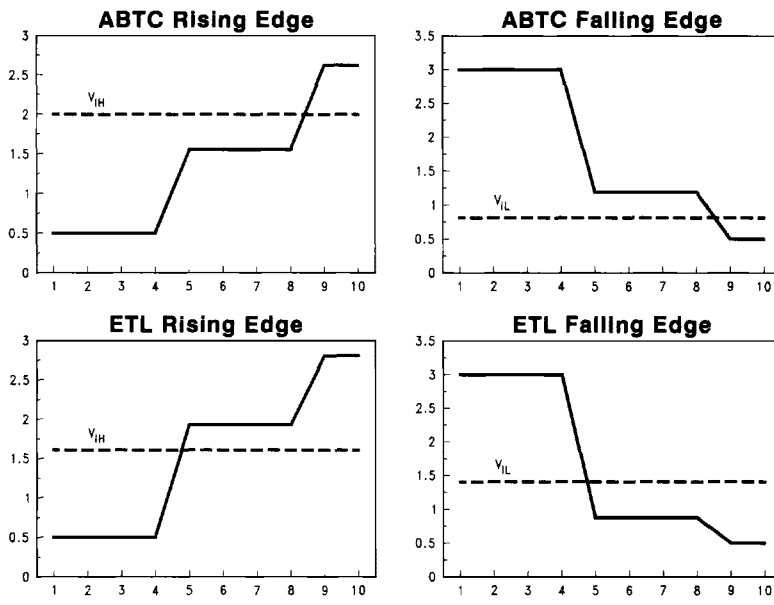

Incident Wave Switching (Continued)

The figure V_{CC} Power-up Critical Voltages shows the relationship between \overline{OE} and V_{CC} while power is being applied and removed.

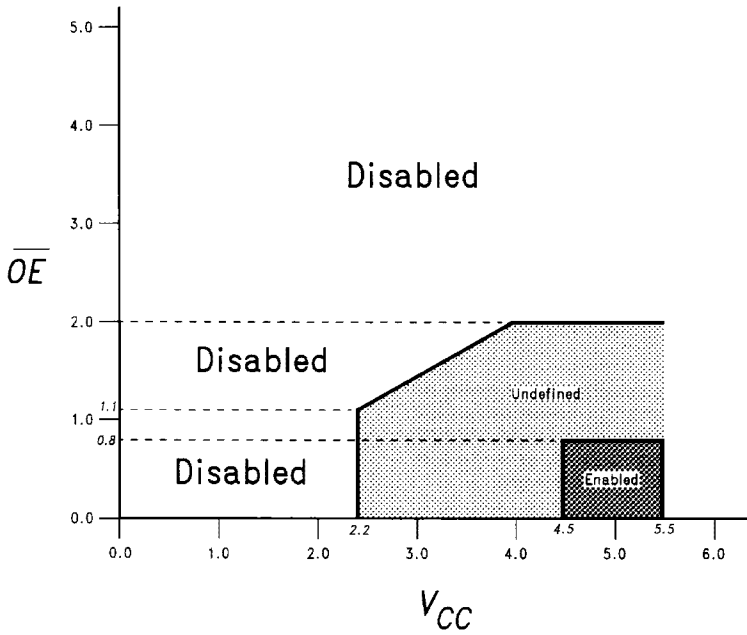

V_{CC} and \overline{OE} Power-up Relationship

TL/F/11654-10

Absolute Maximum Ratings (Note 1)

If Military/Aerospace specified devices are required, please contact the National Semiconductor Sales Office/Distributors for availability and specifications.

Storage Temperature	-65°C to +150°C
Ambient Temperature under Bias	-55°C to +125°C
Junction Temperature under Bias	
Ceramic	-55°C to +175°C
Plastic	-55°C to +150°C
V _{CC} Pin Potential to Ground Pin	-0.5V to +7.0V
Input Voltage (Note 2)	-0.5V to +7.0V
Input Current (Note 2)	-50 mA to +5.0 mA
Voltage Applied to Any Output in the Disabled or Power-off State in the HIGH State	-0.5V to 5.5V -0.5V to V _{CC}
Current Applied to Output in LOW State (Max)	128 mA

DC Latchup Source Current -500 mA

Over Voltage Latchup (I/O) 10V

Note 1: Absolute maximum ratings are values beyond which the device may be damaged or have its useful life impaired. Functional operation under these conditions is not implied.

Note 2: Either voltage limit or current limit is sufficient to protect inputs.

Recommended Operating Conditions

Free Air Ambient Temperature	
Military	-55°C to +125°C
Commercial	-40°C to +85°C
Supply Voltage	
Military	+4.5V to +5.5V
Commercial	+4.5V to +5.5V
Minimum Input Edge Rate	($\Delta t/\Delta V$)
Data Input	20 ns/V
Enable Input	50 ns/V

DC Electrical Characteristics

Symbol	Parameter		ETL16245			Units	V _{CC}	Conditions
			Min	Typ	Max			
V _{IH}	Input HIGH Voltage	\overline{OE}	2.0			V		Recognized HIGH Signal
		Other Inputs	1.6					
V _{IL}	Input LOW Voltage	\overline{OE}			0.8	V		Recognized LOW Signal
		Other Inputs			1.4			
V _{CD}	Input Clamp Diode Voltage				-1.2	V	Min	I _{IN} = -18 mA (\overline{OE}_n , DIR)
V _{OH}	Output HIGH Voltage	B Port			V _{CC} - 1	V	Min	I _{OH} = -100 μ A I _{OH} = -1 mA I _{OH} = -12 mA
				2.4				
			2.0			V		
		A Port			V _{CC} - 1	V		
V _{OL}	Output LOW Voltage	B Port			0.4	V	Min	I _{OL} = 1 mA I _{OL} = 12 mA
						0.8		
		A Port			0.55	V		
					0.9	V		
I _{HOLD}	Bus Hold Current	A Port, B Port	100			μ A	Min	\overline{OE} = HIGH, V _O = 0.8V \overline{OE} = HIGH, V _O = 2.0V
			-100					
I _{OFF}	Output Current, Power Down				100	μ A	0.0	V _{CC} Bias = 0V V _I or V _O \leq 4.5V
I _I	Input Current Control Pins	54ETL			\pm 10	μ A	5.5	V _{IN} = 0 or V _{CC}
		74ETL			\pm 5	μ A	5.5	V _{IN} = 0 or V _{CC}
I _{IH} + I _{OZH}	Output Leakage Current				50	μ A	5.5	V _{OUT} = 2.7V, \overline{OE} = 2.0V
I _{IL} + I _{OZL}	Output Leakage Current				-50	μ A	5.5	V _{OUT} = 0.5V, \overline{OE} = 2.0V

DC Electrical Characteristics (Continued)

Symbol	Parameter	ETL16245			Units	V _{CC}	Conditions
		Min	Typ	Max			
I _{CCH}	Power Supply Current			40	mA	Max	All Outputs HIGH, OE = LOW, DIR = HIGH or LOW
I _{CCL}	Power Supply Current			80	mA	Max	All Outputs LOW, OE = LOW, DIR = HIGH or LOW
I _{CCZ}	Power Supply Current			40	mA	Max	OE = HIGH All Others at V _{CC} or GND DIR = HIGH or LOW
I _{CCD}	Dynamic I _{CC} No Load (Note 1)			0.15	mA/ MHz	Max	Outputs Open OE _n = GND, DIR = HIGH One Bit Toggling, 50% Duty Cycle
V _{OLP}	Quiet Output Maximum Dynamic V _{OL}			1.0	V	5.0	T _A = 25°C (Note 2) C _L = 50 pF; R _L = 500Ω
V _{OLV}	Quiet Output Minimum Dynamic V _{OL}	-1.4			V	5.0	T _A = 25°C (Note 2) C _L = 50 pF; R _L = 500Ω
V _{OHV}	Minimum High Level Dynamic Output Voltage (Note 1)		2.7		V	5.0	T _A = 25°C (Note 4) C _L = 50 pF; R _L = 500Ω
V _{IHD}	Minimum High Level Dynamic Input Voltage (Note 1)	2.0	1.5		V	5.0	T _A = 25°C (Note 3) C _L = 50 pF; R _L = 500Ω
V _{ILD}	Maximum Low Level Dynamic Input Voltage (Note 1)		1.2	0.8	V	5.0	T _A = 25°C (Note 3) C _L = 50 pF; R _L = 500Ω

Note 1: Guaranteed, but not tested.

Note 2: Max. number of outputs defined as (n). n - 1 data inputs are driven 0V to 3V. One output at LOW. Guaranteed, but not tested.

Note 3: Max. number of data inputs (n) switching. n - 1 inputs switching 0V to 3V. Input-under-test switching: 3V to threshold (V_{ILD}), 0V to threshold (V_{IHD}). Guaranteed, but not tested.

Note 4: Max. number of outputs defined as (n). n - 1 data inputs are driven 0V to 3V. One output HIGH. Guaranteed, but not tested.

AC Electrical Characteristics

Symbol	Parameter	74ETL			54ETL		74ETL		Units	Fig. No.
		T _A = +25°C V _{CC} = +5V			T _A = -55°C to +125°C V _{CC} = 4.5V-5.5V		T _A = -40°C to +85°C V _{CC} = 4.5V-5.5V			
		Min	Typ	Max	Min	Max	Min	Max		
t _{PLH}	Propagation	1.5		7.0			1.5	7.0	ns	1, 2, 4
t _{PHL}	Delay A _n to B _n	1.5		7.0			1.5	7.0		
t _{PLH}	Propagation	1.5		7.0			1.5	7.0	ns	1, 2, 4
t _{PHL}	Delay B _n to A _n	1.5		7.0			1.5	7.0		
t _{PZH}	Output Enable	1.0		7.0			1.0	7.0	ns	1, 2, 3
t _{PZL}	Time	1.0		7.0			1.0	7.0		
t _{PHZ}	Output Disable	1.0		7.0			1.0	7.0	ns	1, 2, 3
t _{PLZ}	Time	1.0		7.0			1.0	7.0		
t _r	Rise Time 1V → 2V, A _n Outputs	1.2		3.0			1.2	3.0	ns	1, 2, 4
t _f	Fall Time 2V → 1V, A _n Outputs	1.2		3.0			1.2	3.0	ns	1, 2, 4

Skew

Symbol	Parameter	74ETL	54ETL	Units	Conditions
		$T_A = -40^\circ\text{C to } +85^\circ\text{C}$ $V_{CC} = 4.5\text{V}-5.5\text{V}$ 16 Outputs Switching	$T_A = -55^\circ\text{C to } +125^\circ\text{C}$ $V_{CC} = 4.5\text{V}-5.5\text{V}$ 16 Outputs Switching		
		Max	Max		
t_{OHS} (Notes 1, 2)	Pin-to-Pin Skew LH/HL An to Bn	1.3		ns	Figures 1, 2, 4
t_{OHS} (Notes 1, 2)	Pin-to-Pin Skew LH/HL Bn to An	1.3		ns	Figures 1, 2, 4
t_{PS} (Notes 1, 2)	Duty Cycle Skew Bn to An	2.0		ns	Figures 1, 2, 4
t_{PS} (Notes 1, 2)	Duty Cycle Skew An to Bn	2.0		ns	Figures 1, 2, 4

VME Extended Skew

Symbol	Parameter	74ETL	54ETL	Units	Conditions
		$T_A = -40^\circ\text{C to } +85^\circ\text{C}$ $V_{CC} = 4.5\text{V}-5.5\text{V}$ 16 Outputs Switching	$T_A = -55^\circ\text{C to } +125^\circ\text{C}$ $V_{CC} = 4.5\text{V}-5.5\text{V}$ 16 Outputs Switching		
		Max	Max		
t_{PV} (Notes 1, 2)	Device-to-Device Skew LH/HL Transitions Bn to An	4.0		ns	Figures 1, 2, 4
t_{CP} (Notes 1, 2)	Device-to-Device Skew LH/HL Transitions An to Bn	2.5		ns	Figures 1, 2, 4
t_{CP} (Note 1, 3)	Change in Propagation Delay with Load Bn to An	4.0		ns	Figures 1, 2, 4
t_{CPV} (Notes 1, 2, 3)	Device-to-Device, Change in Propagation Delay with with Load Bn to An	6.0		ns	Figures 1, 2, 4

Note 1: Skew is defined as the absolute difference in delay between two outputs. The specification applies to any outputs switching HIGH to LOW, LOW to HIGH, or any combination switching HIGH-to-LOW or LOW-to-HIGH. This specification is guaranteed but not tested.

Note 2: This is measured with both devices at the same value of $V_{CC} \pm 1\%$ and with package temperature differences of 20°C from each other.

Note 3: This is measured with Rx in Figure 1 at 13Ω for one unit and at 56Ω for the other unit.

Capacitance

Symbol	Parameter	Typ	Max	Units	Conditions, $T_A = 25^\circ\text{C}$
C_{IN}	Input Capacitance	5	8	pF	$V_{CC} = 0.0\text{V}$ (\overline{OE}_n , DIR)
$C_{I/O}$ (Note 1)	Output Capacitance	9	12	pF	$V_{CC} = 5.0\text{V}$ (A_n)

Note 1: $C_{I/O}$ is measured at frequency $f = 1\text{ MHz}$, per MIL-STD-883B, Method 3012.

AC Loading

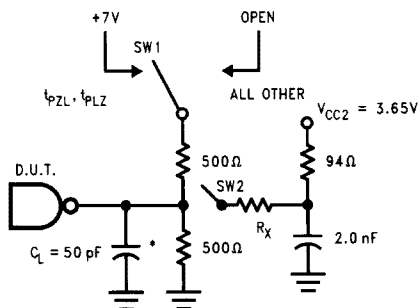

*Includes jig and probe capacitance

TL/F/11654-11

FIGURE 1. Standard AC Test Load

Note 1: Defined to emulate the range of VME bus transmission line loading as a function of board population and driver location. Rx = 13Ω, 26Ω or 56Ω depending on test.

Test	Port	SW1	SW2	Rx
t _{PHZ} , t _{PLZ}	A, B	+7	Open	
t _{PZH} , t _{PZL}	A, B	+7	Open	
t _{PLH} , t _{PHL}	A	Open	Closed	26
t _{PLH} , t _{PHL}	B	Open	Open	
t _r , t _f	A	Open	Closed	26
t _{PV}	A	Open	Closed	26
t _{CP}	B	Open	Open	
t _{CP}	A	Open	Closed	13 then 56
t _{CPV}	A	Open	Closed	13 and 56

FIGURE 1a

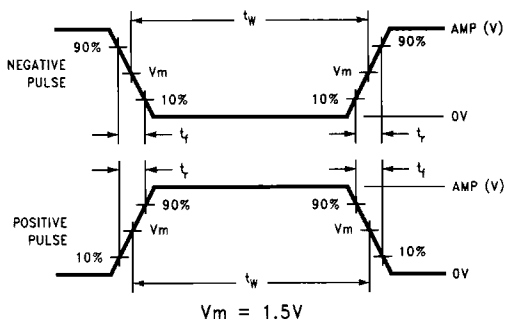

TL/F/11654-12

FIGURE 2. Input Pulse Requirements

Amplitude	Rep. Rate	tw	tr	tf
3.0V	1 MHz	500 ns	2.5 ns	2.5 ns

FIGURE 2a. Test Input Signal Requirements

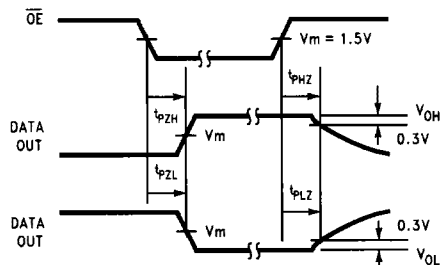

TL/F/11654-13

FIGURE 3. TRI-STATE Output HIGH and LOW Enable and Disable Times

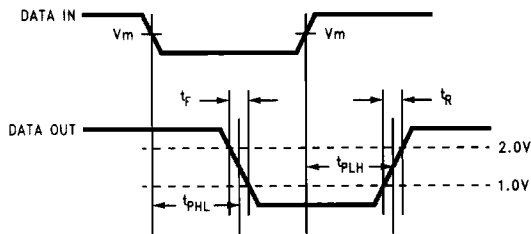

TL/F/11654-14

FIGURE 4. Rise, Fall Time and Propagation Delay Waveforms

Ordering Information

The device number is used to form part of a simplified purchasing code where the package type and temperature range are defined as follows:

