



CY54/74FCT373T CY54/74FCT573T

8-Bit Latches

Features

- Function and pinout compatible with FCT, and F logic
- FCT-C speed at 4.2 ns max. (Com'l), FCT-A speed at 5.2 ns max. (Com'l)
- Reduced V_{OH} (typically = 3.3V) versions of equivalent FCT functions
- Edge-rate control circuitry for significantly improved noise characteristics
- Power-off disable feature
- ESD > 2000V
- Matched rise and fall times
- Extended commercial range of -40°C to $+85^{\circ}\text{C}$
- Fully compatible with TTL input and output logic levels
- Sink current 64 mA (Com'l), 32 mA (Mil)
Source current 32 mA (Com'l), 12 mA (Mil)

Functional Description

The FCT373T and FCT573T consist of eight latches with three-state outputs for bus organized applications. When latch enable (LE) is HIGH, the flip-flops appear transparent to the data. Data that meets the required set-up times are latched when LE transitions from HIGH to LOW. Data appears on the bus when the (\overline{OE}) is LOW. When output enable is HIGH, the bus output is in the impedance state. In this mode, data may be entered into the latches. The FCT573T is identical to the FCT373T except for the flow-through pinout, which simplifies board design.

The outputs are designed with a power-off disable feature to allow for live insertion of boards.

Logic Block Diagram

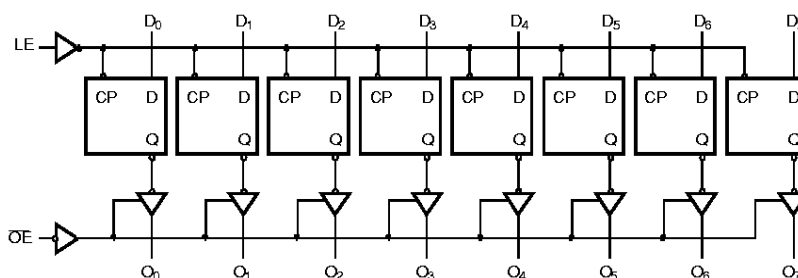

Pin Configurations

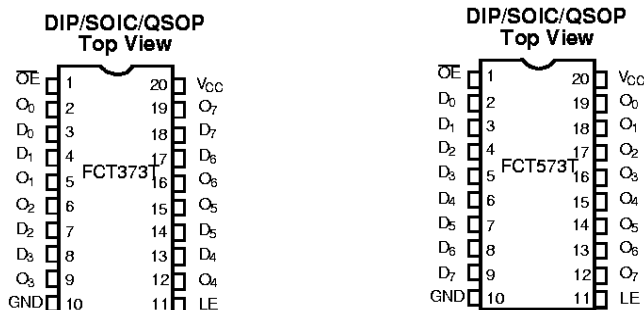

Logic Symbol

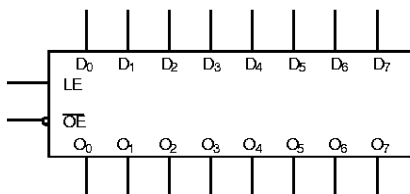



Function Table^[1]

Inputs			Outputs
OE	LE	D	O
L	H	H	H
L	H	L	L
L	L	X	Q ₀
H	X	X	Z

Maximum Ratings^[2, 3]

(Above which the useful life may be impaired. For user guidelines, not tested.)

Storage Temperature -65°C to +150°C

Ambient Temperature with Power Applied -65°C to +135°C

Supply Voltage to Ground Potential -0.5V to +7.0V
 DC Input Voltage -0.5V to +7.0V
 DC Output Voltage -0.5V to +7.0V
 DC Output Current (Maximum Sink Current/Pin) 120 mA
 Power Dissipation 0.5W
 Static Discharge Voltage >2001V (per MIL-STD-883, Method 3015)

Operating Range

Range	Range	Ambient Temperature	V _{CC}
Commercial	DT	0°C to +70°C	5V ± 5%
Commercial	T, AT, CT	-40°C to +85°C	5V ± 5%
Military ^[4]	All	-55°C to +125°C	5V ± 10%

Electrical Characteristics Over the Operating Range

Parameter	Description	Test Conditions		Min.	Typ. ^[5]	Max.	Unit
V _{OH}	Output HIGH Voltage	V _{CC} =Min., I _{OH} =-32 mA	Com'l	2.0			V
		V _{CC} =Min., I _{OH} =-15 mA	Com'l	2.4	3.3		V
		V _{CC} =Min., I _{OH} =-12 mA	Mil	2.4	3.3		V
V _{OL}	Output LOW Voltage	V _{CC} =Min., I _{OL} =64 mA	Com'l		0.3	0.55	V
		V _{CC} =Min., I _{OL} =32 mA	Mil		0.3	0.55	V
V _{IH}	Input HIGH Voltage			2.0			V
V _{IL}	Input LOW Voltage					0.8	V
V _H	Hysteresis ^[6]	All inputs			0.2		V
V _{IK}	Input Clamp Diode Voltage	V _{CC} =Min., I _{IN} =-18 mA			-0.7	-1.2	V
I _I	Input HIGH Current	V _{CC} =Max., V _{IN} =V _{CC}				5	μA
I _{IH}	Input HIGH Current	V _{CC} =Max., V _{IN} =2.7V				±1	μA
I _{IL}	Input LOW Current	V _{CC} =Max., V _{IN} =0.5V				±1	μA
I _{OZH}	Off State HIGH-Level Output Current	V _{CC} =Max., V _{OUT} =2.7V				10	μA
I _{OZL}	Off State LOW-Level Output Current	V _{CC} =Max., V _{OUT} =0.5V				-10	μA
I _{OS}	Output Short Circuit Current ^[7]	V _{CC} =Max., V _{OUT} =0.0V		-60	-120	-225	mA
I _{OFF}	Power-Off Disable	V _{CC} =0V, V _{OUT} =4.5V				±1	μA

Notes:

- H = HIGH Voltage Level
 L = LOW Voltage Level
 X = Don't Care
 Z = HIGH Impedance
 Q_n = Previous state of flip flops (Q_{n-1})
- Unless otherwise noted, these limits are over the operating free-air temperature range.
- Unused inputs must always be connected to an appropriate logic voltage level, preferably either V_{CC} or ground.
- T_A is the "instant on" case temperature.
- Typical values are at V_{CC}=5.0V, T_A=+25°C ambient.
- This parameter is guaranteed but not tested.
- Not more than one output should be shorted at a time. Duration of short should not exceed one second. The use of high-speed test apparatus and/or sample and hold techniques are preferable in order to minimize internal chip heating and more accurately reflect operational values. Otherwise prolonged shorting of a high output may raise the chip temperature well above normal and thereby cause invalid readings in other parametric tests. In any sequence of parameter tests, I_{OS} tests should be performed last.



Capacitance^[6]

Parameter	Description	Typ. ^[5]	Max.	Unit
C _{IN}	Input Capacitance	6	10	pF
C _{OUT}	Output Capacitance	8	12	pF

Power Supply Characteristics

Parameter	Description	Test Conditions	Typ. ^[5]	Max.	Unit
I _{CC}	Quiescent Power Supply Current	V _{CC} =Max., V _{IN} ≤ 0.2V, V _{IN} ≥ V _{CC} - 0.2V	0.1	0.2	mA
ΔI _{CC}	Quiescent Power Supply Current (TTL inputs HIGH)	V _{CC} =Max., V _{IN} =3.4V, f ₁ =0, Outputs Open ^[8]	0.5	2.0	mA
I _{CCD}	Dynamic Power Supply Current ^[9]	V _{CC} =Max., One Input Toggling, 50% Duty Cycle, Outputs Open, OE=GND, V _{IN} ≤ 0.2V or V _{IN} ≥ V _{CC} - 0.2V	0.6	0.12	mA/MHz
I _C	Total Power Supply Current ^[10]	V _{CC} =Max., 50% Duty Cycle, Outputs Open, One Bit Toggling at f ₁ =10 MHz, OE=GND, LE=V _{CC} , V _{IN} ≤ 0.2V or V _{IN} ≥ V _{CC} - 0.2V	0.7	1.4	mA
		V _{CC} =Max., 50% Duty Cycle, Outputs Open, One Bit Toggling at f ₁ =10 MHz, OE=GND, LE=V _{CC} , V _{IN} =3.4V or V _{IN} =GND	1.0	2.4	mA
		V _{CC} =Max., 50% Duty Cycle, Outputs Open, Eight Bits Toggling at f ₁ =2.5 MHz, OE=GND, LE=V _{CC} , V _{IN} ≤ 0.2V or V _{IN} ≥ V _{CC} - 0.2V	1.3	2.6 ^[11]	mA
		V _{CC} =Max., 50% Duty Cycle, Outputs Open, Eight Bits Toggling at f ₁ =2.5 MHz, OE=GND, LE=V _{CC} , V _{IN} =3.4V or V _{IN} =GND	3.3	10.6 ^[11]	mA

Notes:

8. Per TTL driven input (V_{IN}=3.4V); all other inputs at V_{CC} or GND.
9. This parameter is not directly testable, but is derived for use in Total Power Supply calculations.
10. I_C = I_{QUIESCENT} + I_{INPUTS} + I_{DYNAMIC}
 I_C = I_{CC} + ΔI_{CC}D_HN_T + I_{CCD}(f₀/2 + f₁N_I)
 I_{CC} = Quiescent Current with CMOS input levels
 ΔI_{CC} = Power Supply Current for a TTL HIGH input (V_{IN}=3.4V)
 D_H = Duty Cycle for TTL inputs HIGH
 N_T = Number of TTL inputs at D_H
 I_{CCD} = Dynamic Current caused by an input transition pair (HLH or LHL)
 f₀ = Clock frequency for registered devices, otherwise zero
 f₁ = Input signal frequency
 N_I = Number of inputs changing at f₁
 All currents are in milliamps and all frequencies are in megahertz.
11. Values for these conditions are examples of the I_{CC} formula. These limits are guaranteed but not tested.



Switching Characteristics Over the Operating Range^[12]

Parameter	Description	FCT373T/FCT573T				FCT373AT/FCT573AT				Unit	Fig. No. ^[13]
		Military		Commercial		Military		Commercial			
		Min.	Max.	Min.	Max.	Min.	Max.	Min.	Max.		
t _{PLH} t _{PHL}	Propagation Delay D to O	1.5	8.5	1.5	8.0	1.5	5.6	1.5	5.2	ns	1, 3
t _{PLH} t _{PHL}	Propagation Delay LE to O	2.0	15.0	2.0	13.0	2.0	9.8	2.0	8.5	ns	1, 5
t _{PZH} t _{PZL}	Output Enable Time	1.5	13.5	1.5	12.0	1.5	7.5	1.5	6.5	ns	1, 7, 8
t _{PHZ} t _{PLZ}	Output Disable Time	1.5	10.0	1.5	7.5	1.5	6.5	1.5	5.5	ns	1, 7, 8
t _S	Set-Up Time HIGH to LOW D to LE	2.0		2.0		2.0		2.0		ns	9
t _H	Set-Up Time HIGH to LOW D to LE	1.5		1.5		1.5		1.5		ns	9
t _w	LE Pulse Width HIGH	6.0		6.0		6.0		5.0		ns	5

Parameter	Description	FCT373CT/ FCT573CT		FCT373DT/ FCT573DT		Unit	Fig. No. ^[13]
		Commercial		Commercial			
		Min.	Max.	Min.	Max.		
t _{PLH} t _{PHL}	Propagation Delay D to O	1.5	4.2	1.5	3.8	ns	1, 3
t _{PLH} t _{PHL}	Propagation Delay LE to O	2.0	5.5	2.0	4.0	ns	1, 5
t _{PZH} t _{PZL}	Output Enable Time	1.5	5.5	1.5	4.8	ns	1, 7, 8
t _{PHZ} t _{PLZ}	Output Disable Time	1.5	5.0	1.5	4.0	ns	1, 7, 8
t _S	Set-Up Time, HIGH to LOW D to LE	2.0		1.5		ns	9
t _H	Set-Up Time, HIGH to LOW D to LE	1.5		1.0		ns	9
t _w	LE Pulse Width HIGH	5.0		3.0		ns	5

Shaded areas contain preliminary information.

Note:

- 12. Minimum limits are guaranteed but not tested on Propagation Delays.
- 13. See "Parameter Measurement Information" in the General Information section.



Ordering Information—FCT373T

Speed (ns)	Ordering Code	Package Name	Package Type	Operating Range
3.8	CY74FCT373DTQC	Q5	20-Lead (150-Mil) QSOP	Commercial
	CY74FCT373DTSOC	S5	20-Lead (300-Mil) Molded SOIC	
4.2	CY74FCT373CTQC	Q5	20-Lead (150-Mil) QSOP	Commercial
	CY74FCT373CTSOC	S5	20-Lead (300-Mil) Molded SOIC	
5.2	CY74FCT373ATPC	P5	20-Lead (300-Mil) Molded DIP	Commercial
	CY74FCT373ATQC	Q5	20-Lead (150-Mil) QSOP	
	CY74FCT373ATSOC	S5	20-Lead (300-Mil) Molded SOIC	
5.6	CY54FCT373ATDMB	D6	20-Lead (300-Mil) CerDIP	Military
8.0	CY74FCT373TQC	Q5	20-Lead (150-Mil) QSOP	Commercial
	CY74FCT373TSOC	S5	20-Lead (300-Mil) Molded SOIC	
8.5	CY54FCT373TDMB	D6	20-Lead (300-Mil) CerDIP	Military

Ordering Information—FCT573T

Speed (ns)	Ordering Code	Package Name	Package Type	Operating Range
3.8	CY74FCT573DTQC	Q5	20-Lead (150-Mil) QSOP	Commercial
	CY74FCT573DTSOC	S5	20-Lead (300-Mil) Molded SOIC	
4.2	CY74FCT573CTQC	Q5	20-Lead (150-Mil) QSOP	Commercial
	CY74FCT573CTSOC	S5	20-Lead (300-Mil) Molded SOIC	
5.2	CY74FCT573ATPC	P5	20-Lead (300-Mil) Molded DIP	Commercial
	CY74FCT573ATQC	Q5	20-Lead (150-Mil) QSOP	
	CY74FCT573ATSOC	S5	20-Lead (300-Mil) Molded SOIC	
5.6	CY54FCT573ATDMB	D6	20-Lead (300-Mil) CerDIP	Military
8.0	CY74FCT573TQC	Q5	20-Lead (150-Mil) QSOP	Commercial
	CY74FCT573TSOC	S5	20-Lead (300-Mil) Molded SOIC	
8.5	CY54FCT573TDMB	D6	20-Lead (300-Mil) CerDIP	Military

Shaded areas contain preliminary information.

Document #: 38-00272-B

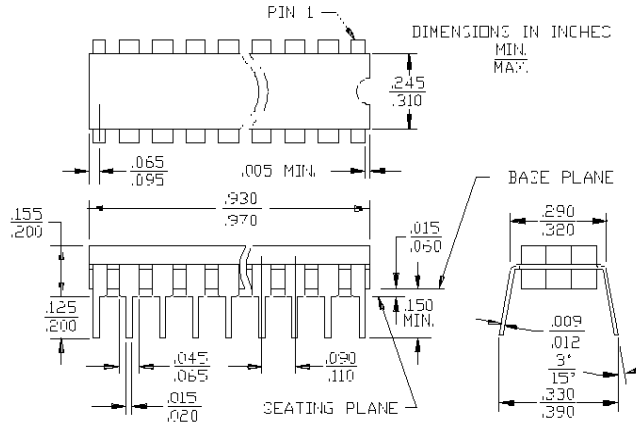
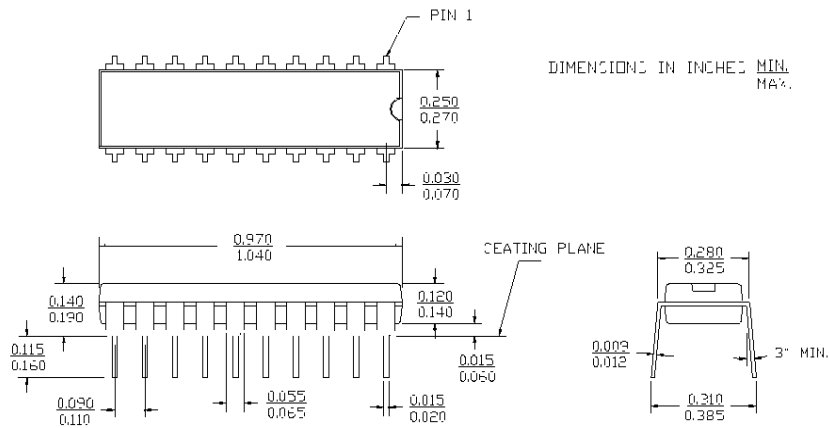
Package Diagrams
20-Lead (300-Mil) CerDIP D6
 MIL-STD-1835 D-8 Config.A

20-Lead (300-Mil) Molded DIP P5

Package Diagrams (continued)

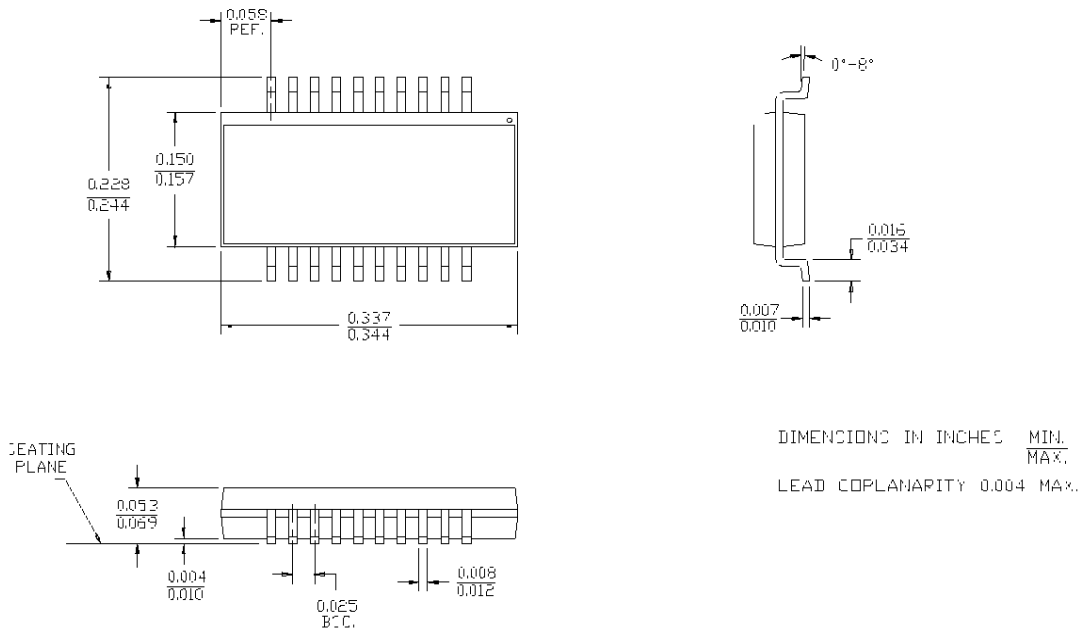
20-Lead Quarter Size Outline Q5



20-Lead (300-Mil) Molded SOIC S5

