

# 54ABT/74ABT373

## Octal Transparent Latch with TRI-STATE® Outputs

### General Description

The 'ABT373 consists of eight latches with TRI-STATE outputs for bus organized system applications. The flip-flops appear transparent to the data when Latch Enable (LE) is HIGH. When LE is LOW, the data that meets the setup times is latched. Data appears on the bus when the Output Enable ( $\overline{OE}$ ) is LOW. When  $\overline{OE}$  is HIGH the bus output is in the high impedance state.

### Features

- TRI-STATE outputs for bus interfacing
- Output sink capability of 64 mA, source capability of 32 mA

- Guaranteed output skew
- Guaranteed multiple output switching specifications
- Output switching specified for both 50 pF and 250 pF loads
- Guaranteed simultaneous switching, noise level and dynamic threshold performance
- Guaranteed latchup protection
- High impedance glitch free bus loading during entire power up and power down
- Nondestructive hot insertion capability
- Standard Military Drawing (SMD) 5962-9321801

**Ordering Code:** See Section 10

Commercial	Military	Package Number	Package Description
74ABT373CSC (Note 1)		M20B	20-Lead (0.300" Wide) Molded Small Outline, JEDEC
74ABT373CSJ (Note 1)		M20D	20-Lead (0.300" Wide) Molded Small Outline, EIAJ
74ABT373CPC		N20B	20-Lead (0.300" Wide) Molded Dual-In-Line
	54ABT373J/883	J20A	20-Lead Ceramic Dual-In-Line
74ABT373CMSA (Note 1)		MSA20	20-Lead Molded Shrink Small Outline, EIAJ Type II
	54ABT373W/883	W20A	20-Lead Cerpack
	54ABT373E/883	E20A	20-Lead Ceramic Leadless Chip Carrier, Type C
74ABT373CMTC (Notes 1, 2)		MTC20	20-Lead Molded Thin Shrink Small Outline, JEDEC

**Note 1:** Devices also available in 13" reel. Use suffix = SCX, SJX, MSAX, and MTCX.

**Note 2:** Contact factory for package availability.

### Connection Diagrams

**Pin Assignment for DIP, SOIC, SSOP and Flatpak**

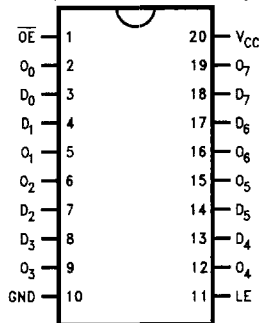

TL/F/11547-1

**Pin Assignment for LCC**

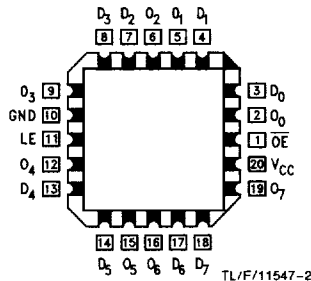

TL/F/11547-2

Pin Names	Description
D <sub>0</sub> -D <sub>7</sub>	Data Inputs
LE	Latch Enable Input (Active HIGH)
$\overline{OE}$	Output Enable Input (Active LOW)
O <sub>0</sub> -O <sub>7</sub>	TRI-STATE Latch Outputs

## Functional Description

The ABT373 contains eight D-type latches with TRI-STATE output buffers. When the Latch Enable (LE) input is HIGH, data on the  $D_n$  inputs enters the latches. In this condition the latches are transparent, i.e., a latch output will change state each time its D input changes. When LE is LOW, the latches store the information that was present on the D inputs a setup time preceding the HIGH-to-LOW transition of LE. The TRI-STATE buffers are controlled by the Output Enable ( $\overline{OE}$ ) input. When  $\overline{OE}$  is LOW, the buffers are in the bi-state mode. When  $\overline{OE}$  is HIGH the buffers are in the high impedance mode but this does not interfere with entering new data into the latches.

## Truth Table

Inputs			Output
LE	$\overline{OE}$	$D_n$	$O_n$
H	L	H	H
H	L	L	L
L	L	X	$O_n$ (no change)
X	H	X	Z

H = HIGH Voltage Level  
 L = LOW Voltage Level  
 X = Immaterial  
 Z = High Impedance State

## Logic Diagram

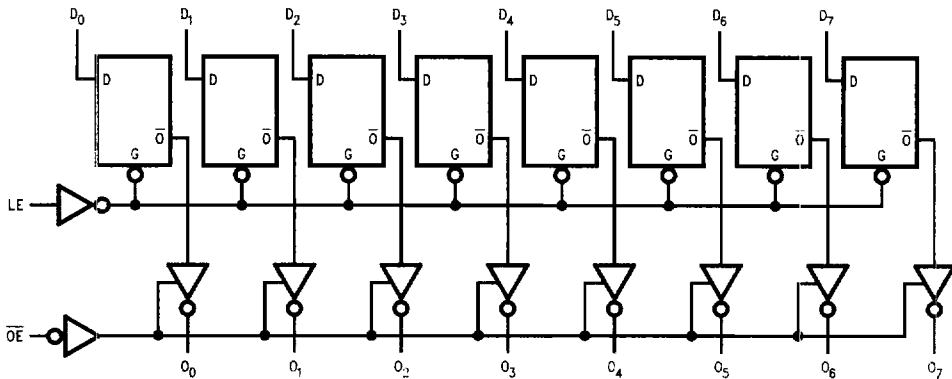

TLF11547-3

Please note that this diagram is provided only for the understanding of logic operations and should not be used to estimate propagation delays.

## Absolute Maximum Ratings (Note 1)

If Military/Aerospace specified devices are required, please contact the National Semiconductor Sales Office/Distributors for availability and specifications.

Storage Temperature	-65°C to +150°C
Ambient Temperature under Bias	-55°C to +125°C
Junction Temperature under Bias	
Ceramic	-55°C to +175°C
Plastic	-55°C to +150°C
V <sub>CC</sub> Pin Potential to Ground Pin	-0.5V to +7.0V
Input Voltage (Note 2)	-0.5V to +7.0V
Input Current (Note 2)	-30 mA to +5.0 mA
Voltage Applied to Any Output in the Disabled or Power-Off State in the HIGH State	-0.5V to +5.5V -0.5V to V <sub>CC</sub>
Current Applied to Output in LOW State (Max)	twice the rated I <sub>OL</sub> (mA)

DC Latchup Source Current:	$\overline{OE}$ Pin	-150 mA
(Across Comm Operating Range)	Other Pins	-500 mA
Over Voltage Latchup (I/O)		10V

**Note 1:** Absolute maximum ratings are values beyond which the device may be damaged or have its useful life impaired. Functional operation under these conditions is not implied.

**Note 2:** Either voltage limit or current limit is sufficient to protect inputs.

## Recommended Operating Conditions

Free Air Ambient Temperature	
Military	-55°C to +125°C
Commercial	-40°C to +85°C
Supply Voltage	
Military	+4.5V to +5.5V
Commercial	+4.5V to +5.5V
Minimum Input Edge Rate	( $\Delta V/\Delta t$ )
Data Input	50 mV/ns
Enable Input	20 mV/ns

## DC Electrical Characteristics

Symbol	Parameter	ABT373			Units	V <sub>CC</sub>	Conditions
		Min	Typ	Max			
V <sub>IH</sub>	Input HIGH Voltage <sup>a</sup>	2.0			V		Recognized HIGH Signal
V <sub>IL</sub>	Input LOW Voltage			0.8	V		Recognized LOW Signal
V <sub>CD</sub>	Input Clamp Diode Voltage			-1.2	V	Min	I <sub>IH</sub> = -18 mA
V <sub>OH</sub>	Output HIGH Voltage	54ABT/74ABT 54ABT 74ABT	2.5 2.0 2.0		V	Min	I <sub>OH</sub> = -3 mA I <sub>OH</sub> = -24 mA I <sub>OH</sub> = -32 mA
V <sub>OL</sub>	Output LOW Voltage	54ABT 74ABT	0.55 0.55		V	Min	I <sub>OL</sub> = 48 mA I <sub>OL</sub> = 64 mA
I <sub>IH</sub>	Input HIGH Current		5 5		μA	Max	V <sub>IN</sub> = 2.7V (Note 2) V <sub>IN</sub> = V <sub>CC</sub>
I <sub>BVI</sub>	Input HIGH Current Breakdown Test		7		μA	Max	V <sub>IN</sub> = 7.0V
I <sub>IL</sub>	Input LOW Current		-5 -5		μA	Max	V <sub>IN</sub> = 0.5V (Note 2) V <sub>IN</sub> = 0.0V
V <sub>ID</sub>	Input Leakage Test	4.75			V	0.0	I <sub>ID</sub> = 1.9 μA All Other Pins Grounded
I <sub>OZH</sub>	Output Leakage Current		50		μA	0 - 5.5V	V <sub>OUT</sub> = 2.7V; $\overline{OE}$ = 2.0V
I <sub>OZL</sub>	Output Leakage Current		-50		μA	0 - 5.5V	V <sub>OUT</sub> = 0.5V; $\overline{OE}$ = 2.0V
I <sub>OS</sub>	Output Short-Circuit Current	-100	-275		mA	Max	V <sub>OUT</sub> = 0.0V
I <sub>CEX</sub>	Output High Leakage Current		50		μA	Max	V <sub>OUT</sub> = V <sub>CC</sub>
I <sub>ZZ</sub>	Bus Drainage Test		100		μA	0.0	V <sub>OUT</sub> = 5.5V; All Others GND
I <sub>CCH</sub>	Power Supply Current		50		μA	Max	All Outputs HIGH
I <sub>CCL</sub>	Power Supply Current		30		mA	Max	All Outputs LOW
I <sub>CCZ</sub>	Power Supply Current		50		μA	Max	$\overline{OE}$ = V <sub>CC</sub> All Others at V <sub>CC</sub> or GND
I <sub>CC1</sub>	Additional I <sub>CC</sub> /Input	Outputs Enabled Outputs TRI-STATE Outputs TRI-STATE	2.5 2.5 2.5		mA mA mA	Max	V <sub>I</sub> = V <sub>CC</sub> - 2.1V Enable Input V <sub>I</sub> = V <sub>CC</sub> - 2.1V Data Input V <sub>I</sub> = V <sub>CC</sub> - 2.1V All Others at V <sub>CC</sub> or GND
I <sub>CCD</sub>	Dynamic I <sub>CC</sub> (Note 2)	No Load		0.12	mA/ MHz	Max	Outputs Open, LE = V <sub>CC</sub> $\overline{OE}$ = GND, (Note 1) One Bit Toggling, 50% Duty Cycle

**Note 1:** For 8 bits toggling, I<sub>CCD</sub> < 0.8 mA/MHz.

**Note 2:** Guaranteed, but not tested.

## DC Electrical Characteristics (SOIC Package) (Continued)

Symbol	Parameter	Min	Typ	Max	Units	V <sub>CC</sub>	Conditions
							C <sub>L</sub> = 50 pF, R <sub>L</sub> = 500Ω
V <sub>OLP</sub>	Quiet Output Maximum Dynamic V <sub>OL</sub>		0.4	0.8	V	5.0	T <sub>A</sub> = 25°C (Note 1)
V <sub>OLV</sub>	Quiet Output Minimum Dynamic V <sub>OL</sub>	-1.2	-0.8		V	5.0	T <sub>A</sub> = 25°C (Note 1)
V <sub>OHV</sub>	Minimum High Level Dynamic Output Voltage	2.5	3.0		V	5.0	T <sub>A</sub> = 25°C (Note 3)
V <sub>IHD</sub>	Minimum High Level Dynamic Input Voltage	2.0	1.7		V	5.0	T <sub>A</sub> = 25°C (Note 2)
V <sub>ILD</sub>	Maximum Low Level Dynamic Input Voltage		0.9	0.6	V	5.0	T <sub>A</sub> = 25°C (Note 2)

**Note 1:** Max number of outputs defined as (n). n - 1 data inputs are driven 0V to 3V. One output at Low. Guaranteed, but not tested.

**Note 2:** Max number of data inputs (n) switching. n - 1 inputs switching 0V to 3V. Input-under-test switching: 3V to threshold (V<sub>ILD</sub>). 0V to threshold (V<sub>IHD</sub>). Guaranteed, but not tested.

**Note 3:** Max number of outputs defined as (n). n - 1 data inputs are driven 0V to 3V. One output HIGH. Guaranteed, but not tested.

## AC Electrical Characteristics: See Section 2 for Waveforms (SOIC and SSOP Packages)

Symbol	Parameter	74ABT			54ABT		74ABT		Units	Fig. No.
		T <sub>A</sub> = +25°C V <sub>CC</sub> = +5.0V C <sub>L</sub> = 50 pF			T <sub>A</sub> = -55°C to +125°C V <sub>CC</sub> = 4.5V to 5.5V C <sub>L</sub> = 50 pF		T <sub>A</sub> = -40°C to +85°C V <sub>CC</sub> = 4.5V to 5.5V C <sub>L</sub> = 50 pF			
		Min	Typ	Max	Min	Max	Min	Max		
t <sub>PLH</sub>	Propagation Delay D <sub>n</sub> to O <sub>n</sub>	1.9	2.7	4.5	1.0	6.8	1.9	4.5	ns	2-3, 5
t <sub>PHL</sub>	Propagation Delay LE to O <sub>n</sub>	1.9	2.8	4.5	1.0	7.0	1.9	4.5	ns	2-3, 5
t <sub>PLH</sub>	Propagation Delay LE to O <sub>n</sub>	2.0	3.1	5.0	1.0	7.7	2.0	5.0	ns	2-3, 5
t <sub>PHL</sub>	Propagation Delay LE to O <sub>n</sub>	2.0	3.0	5.0	1.5	7.7	2.0	5.0	ns	2-3, 5
t <sub>pZH</sub>	Output Enable Time	1.5	3.1	5.3	1.0	6.7	1.5	5.3	ns	2-4
t <sub>pZL</sub>	Output Disable Time	1.5	3.1	5.3	1.5	7.2	1.5	5.3	ns	2-4
t <sub>PHZ</sub>	Output Disable Time	2.0	3.6	5.4	1.7	8.0	2.0	5.4	ns	2-4
t <sub>PLZ</sub>	Output Disable Time	2.0	3.4	5.4	1.0	7.0	2.0	5.4	ns	2-4

## AC Operating Requirements: See Section 2 for Waveforms (SOIC and SSOP Packages)

Symbol	Parameter	74ABT			54ABT		74ABT		Units	Fig. No.
		T <sub>A</sub> = +25°C V <sub>CC</sub> = +5.0V C <sub>L</sub> = 50 pF			T <sub>A</sub> = -55°C to +125°C V <sub>CC</sub> = 4.5V to 5.5V C <sub>L</sub> = 50 pF		T <sub>A</sub> = -40°C to +85°C V <sub>CC</sub> = 4.5V to 5.5V C <sub>L</sub> = 50 pF			
		Min	Typ	Max	Min	Max	Min	Max		
f <sub>toggle</sub>	Max Toggle Frequency		100		100				MHz	
t <sub>s</sub> (H)	Setup Time, HIGH	1.5			2.5		1.5		ns	2-6
t <sub>s</sub> (L)	Setup Time, LOW or LOW D <sub>n</sub> to LE	1.5			2.5		1.5		ns	2-6
t <sub>h</sub> (H)	Hold Time, HIGH	1.0			2.5		1.0		ns	2-6
t <sub>h</sub> (L)	Hold Time, LOW or LOW D <sub>n</sub> to LE	1.0			2.5		1.0		ns	2-6
t <sub>w</sub> (H)	Pulse Width, LE HIGH	3.0			3.3		3.0		ns	2-3

## Extended AC Electrical Characteristics: See Section 2 for Waveforms (SOIC package)

Symbol	Parameter	74ABT		74ABT		74ABT		Units	Fig. No.
		$T_A = -40^\circ\text{C to } +85^\circ\text{C}$ $V_{CC} = 4.5\text{V to } 5.5\text{V}$ $C_L = 50\text{ pF}$ 8 Outputs Switching (Note 4)		$T_A = -40^\circ\text{C to } +85^\circ\text{C}$ $V_{CC} = 4.5\text{V to } 5.5\text{V}$ $C_L = 250\text{ pF}$ (Note 5)		$T_A = -40^\circ\text{C to } +85^\circ\text{C}$ $V_{CC} = 4.5\text{V to } 5.5\text{V}$ $C_L = 250\text{ pF}$ 8 Outputs Switching (Note 6)			
		Min	Max	Min	Max	Min	Max		
$t_{PLH}$ $t_{PHL}$	Propagation Delay $D_n$ to $O_n$	1.5	5.2	2.0	6.8	2.0	9.0	ns	2-3, 5
$t_{PLH}$ $t_{PHL}$	Propagation Delay LE to $O_n$	1.5	5.5	2.0	7.5	2.0	9.5	ns	2-3, 5
$t_{PZH}$ $t_{PZL}$	Output Enable Time	1.5	6.2	2.0	8.0	2.0	10.5	ns	2-4
$t_{PHZ}$ $t_{PZL}$	Output Disable Time	1.0	5.5	(Note 7)		(Note 7)		ns	2-4

**Note 4:** This specification is guaranteed but not tested. The limits apply to propagation delays for all paths described switching in phase (i.e., all LOW-to-HIGH, HIGH-to-LOW, etc.).

**Note 5:** This specification is guaranteed but not tested. The limits represent propagation delay with 250 pF load capacitors in place of the 50 pF load capacitors in the standard AC load. This specification pertains to single output switching only.

**Note 6:** This specification is guaranteed but not tested. The limits represent propagation delays for all paths described switching in phase (i.e., all LOW-to-HIGH, HIGH-to-LOW, etc.) with 250 pF load capacitors in place of the 50 pF load capacitors in the standard AC load.

**Note 7:** The TRI-STATE delay times are dominated by the RC network (500 $\Omega$ , 250 pF) on the output and has been excluded from the datasheet.

### Skew: See Section 2 (SOIC Package)

Symbol	Parameter	74ABT		74ABT		Units	Fig. No.
		$T_A = -40^\circ\text{C to } +85^\circ\text{C}$ $V_{CC} = 4.5\text{V}-5.5\text{V}$ $C_L = 50\text{ pF}$ 8 Outputs Switching (Note 3)		$T_A = -40^\circ\text{C to } +85^\circ\text{C}$ $V_{CC} = 4.5\text{V}-5.5\text{V}$ $C_L = 250\text{ pF}$ 8 Outputs Switching (Note 4)			
		Max		Max			
$t_{OSH}$ (Note 1)	Pin to Pin Skew HL Transitions	1.0		1.5		ns	2-13
$t_{OSLH}$ (Note 1)	Pin to Pin Skew LH Transitions	1.0		1.5		ns	2-13
$t_{PS}$ (Note 5)	Duty Cycle LH-HL Skew	1.4		3.5		ns	2-14
$t_{OST}$ (Note 1)	Pin to Pin Skew LH/HL Transitions	1.5		3.9		ns	2-17
$t_{PV}$ (Note 2)	Device to Device Skew LH/HL Transitions	2.0		4.0		ns	2-20

**Note 1:** Skew is defined as the absolute value of the difference between the actual propagation delays for any two separate outputs of the same device. The specification applies to any outputs switching HIGH to LOW ( $t_{OSH}$ ), LOW to HIGH ( $t_{OSLH}$ ), or any combination switching LOW to HIGH and/or HIGH to LOW ( $t_{OST}$ ). This specification is guaranteed but not tested.

**Note 2:** Propagation delay variation for a given set of conditions (i.e., temperature and  $V_{CC}$ ) from device to device. This specification is guaranteed but not tested.

**Note 3:** This specification is guaranteed but not tested. The limits apply to propagation delays for all paths described switching in phase (i.e., all LOW-to-HIGH, HIGH-to-LOW, etc.).

**Note 4:** This specification is guaranteed but not tested. The limits represent propagation delays with 250 pF load capacitors in place of the 50 pF load capacitors in the standard AC load.

**Note 5:** This describes the difference between the delay of the LOW-to-HIGH and the HIGH-to-LOW transition on the same pin. It is measured across all the outputs (drivers) on the same chip, the worst (largest delta) number is the guaranteed specification. This specification is guaranteed but not tested.

## Capacitance

Symbol	Parameter	Typ	Units	Conditions ( $T_A = 25^\circ\text{C}$ )
$C_{IN}$	Input Capacitance	5	pF	$V_{CC} = 0\text{V}$
$C_{OUT}$ (Note 1)	Output Capacitance	9	pF	$V_{CC} = 5.0\text{V}$

**Note 1:**  $C_{OUT}$  is measured at frequency  $f = 1\text{ MHz}$ , per MIL-STD-883B, Method 3012.

**$t_{PLH}$  vs Temperature ( $T_A$ )**  
 $C_L = 50\text{ pF}$ , 1 Output Switching  
 Data to Output

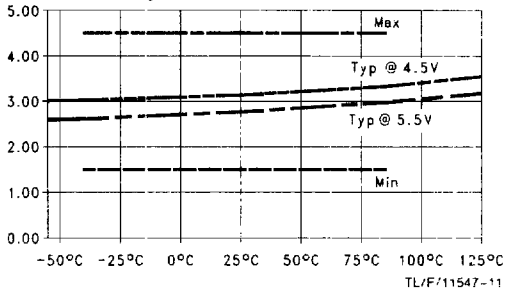

**$t_{PHL}$  vs Temperature ( $T_A$ )**  
 $C_L = 50\text{ pF}$ , 1 Output Switching  
 Data to Output

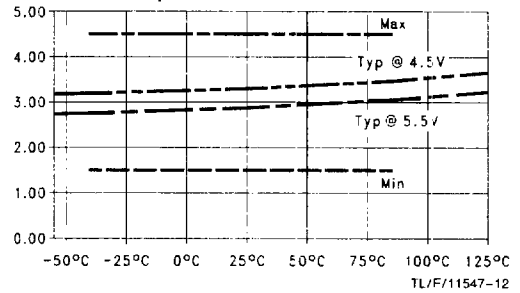

**$t_{pZH}$  vs Temperature ( $T_A$ )**  
 $C_L = 50\text{ pF}$ , 1 Output Switching  
 OE to Output

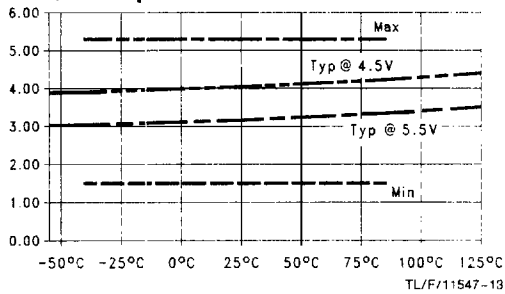

**$t_{pZL}$  vs Temperature ( $T_A$ )**  
 $C_L = 50\text{ pF}$ , 1 Output Switching  
 OE to Output

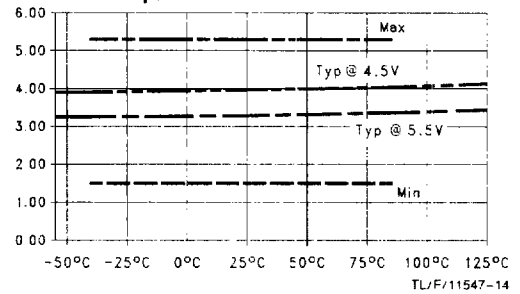

**$t_{pHZ}$  vs Temperature ( $T_A$ )**  
 $C_L = 50\text{ pF}$ , 1 Output Switching  
 OE to Output

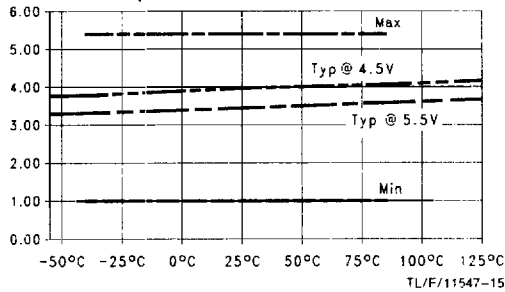

**$t_{pLZ}$  vs Temperature ( $T_A$ )**  
 $C_L = 50\text{ pF}$ , 1 Output Switching  
 OE to Output

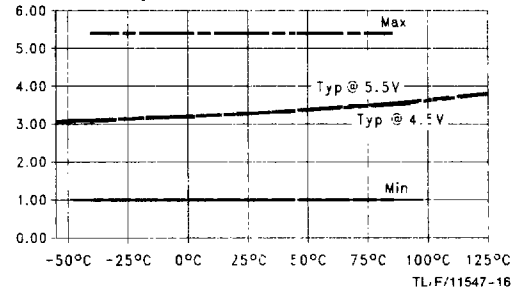

Dashed lines represent design characteristics; for specified guarantees, refer to AC Characteristics Tables

**t<sub>SET</sub> LOW vs Temperature (T<sub>A</sub>)**  
**C<sub>L</sub> = 50 pF, 1 Output Switching**  
**Data to LE**

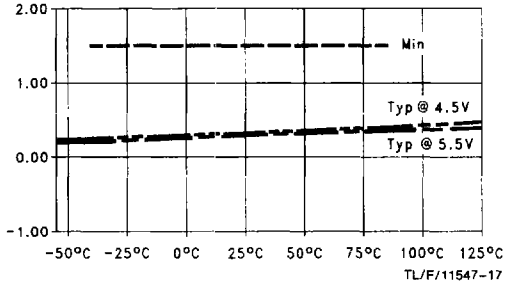

**t<sub>SET</sub> HIGH vs Temperature (T<sub>A</sub>)**  
**C<sub>L</sub> = 50 pF, 1 Output Switching**  
**Data to LE**

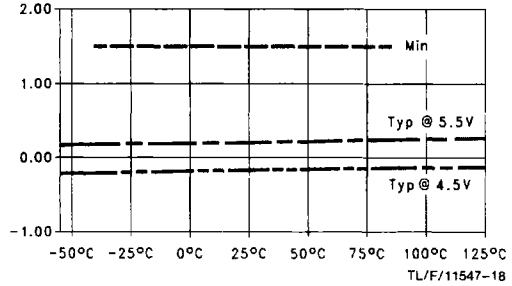

**t<sub>HOLD</sub> HIGH vs Temperature (T<sub>A</sub>)**  
**C<sub>L</sub> = 50 pF, 1 Output Switching**  
**Data to LE**

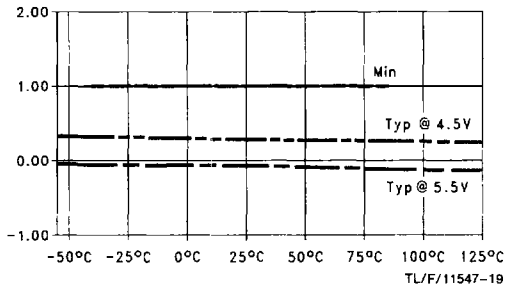

**t<sub>HOLD</sub> LOW vs Temperature (T<sub>A</sub>)**  
**C<sub>L</sub> = 50 pF, 1 Output Switching**  
**Data to LE**

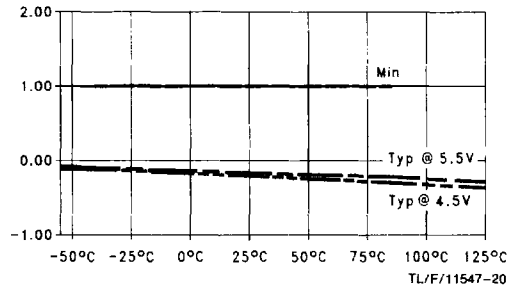

**t<sub>PLH</sub> vs Temperature (T<sub>A</sub>)**  
**C<sub>L</sub> = 50 pF, 8 Outputs Switching**  
**Data to Output**

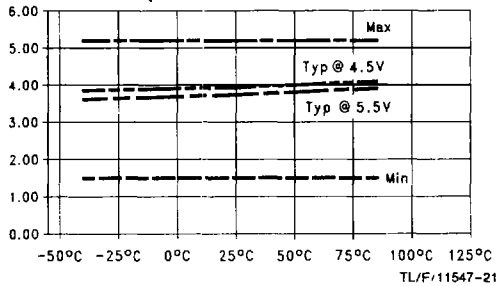

**t<sub>PHL</sub> vs Temperature (T<sub>A</sub>)**  
**C<sub>L</sub> = 50 pF, 8 Outputs Switching**  
**Data to Output**

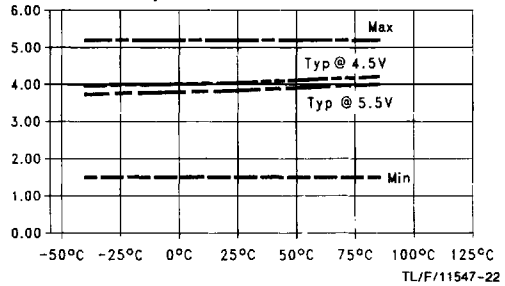

**t<sub>pZH</sub> vs Temperature (T<sub>A</sub>)**  
**C<sub>L</sub> = 50 pF, 8 Outputs Switching**  
**OE to Output**

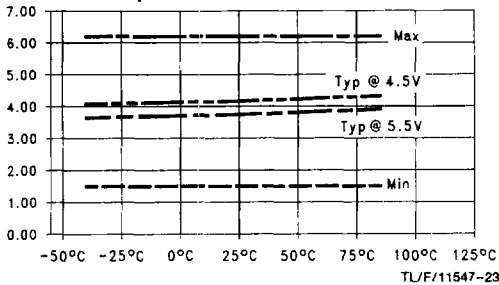

**t<sub>pZL</sub> vs Temperature (T<sub>A</sub>)**  
**C<sub>L</sub> = 50 pF, 8 Outputs Switching**  
**OE to Output**

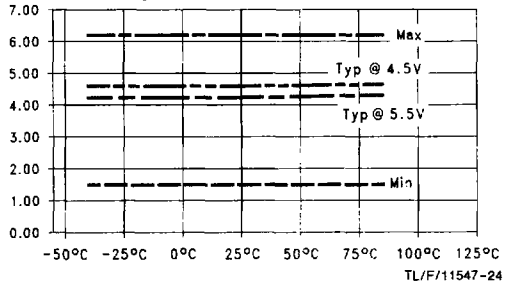

Dashed lines represent design characteristics; for specified guarantees, refer to AC Characteristics Tables.

**tpHZ vs Temperature (T<sub>A</sub>)**  
**C<sub>L</sub> = 50 pF, 8 Outputs Switching**  
**OE to Output**

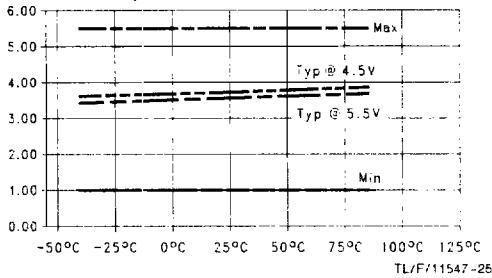

**tpLZ vs Temperature (T<sub>A</sub>)**  
**C<sub>L</sub> = 50 pF, 8 Outputs Switching**  
**OE to Output**

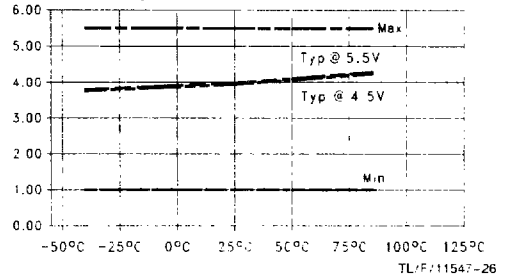

**tpLH vs Load Capacitance**  
**T<sub>A</sub> = 25°C, 1 Output Switching**  
**Data to Output**

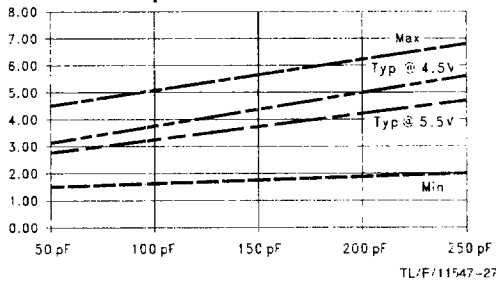

**tpHL vs Load Capacitance**  
**T<sub>A</sub> = 25°C, 1 Output Switching**  
**Data to Output**

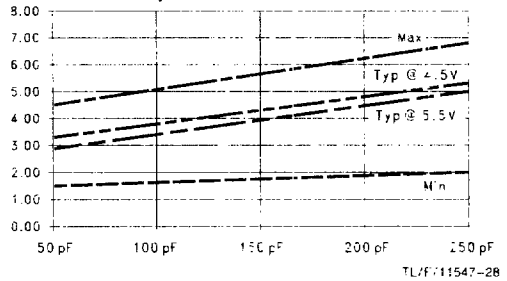

**tpLH vs Load Capacitance**  
**T<sub>A</sub> = 25°C, 8 Outputs Switching**  
**Data to Output**

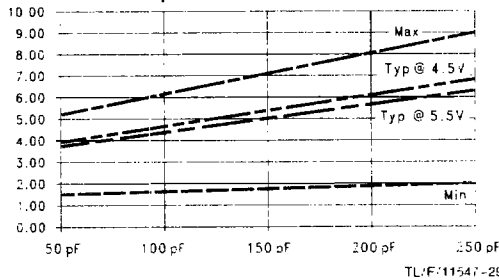

**tpHL vs Load Capacitance**  
**T<sub>A</sub> = 25°C, 8 Outputs Switching**  
**Data to Output**

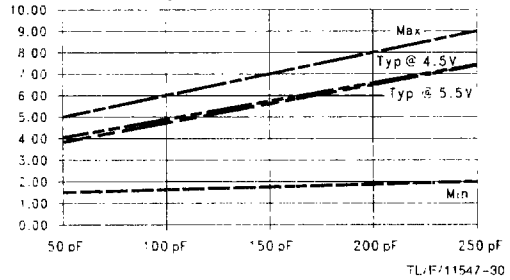

**tpZH vs Load Capacitance**  
**T<sub>A</sub> = 25°C, 8 Outputs Switching**  
**OE to Output**

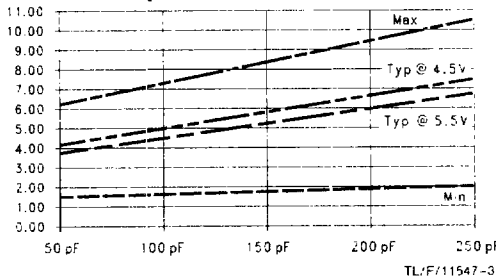

**tpZL vs Load Capacitance**  
**T<sub>A</sub> = 25°C, 8 Outputs Switching**  
**OE to Output**

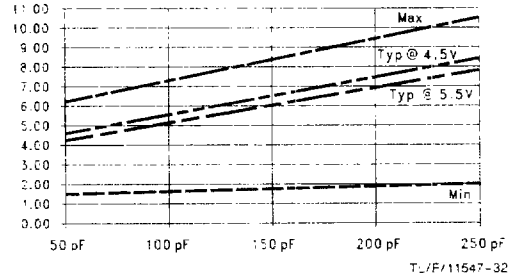

Dashed lines represent design characteristics; for specified guarantees, refer to AC Characteristics Tables.



**$t_{PLH}$  vs Temperature ( $T_A$ )**  
 **$C_L = 50$  pF, 1 Output Switching**  
**LE to Output**

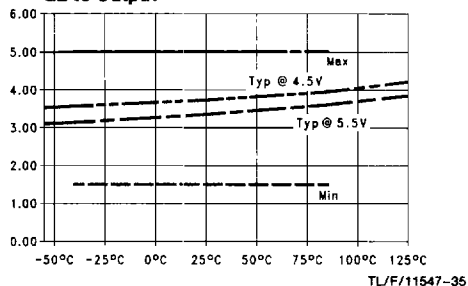

**$t_{PHL}$  vs Temperature ( $T_A$ )**  
 **$C_L = 50$  pF, 1 Output Switching**  
**LE to Output**

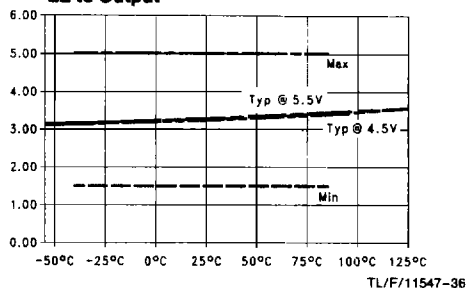

**$t_{PLH}$  vs Temperature ( $T_A$ )**  
 **$C_L = 50$  pF, 8 Outputs Switching**  
**LE to Output**

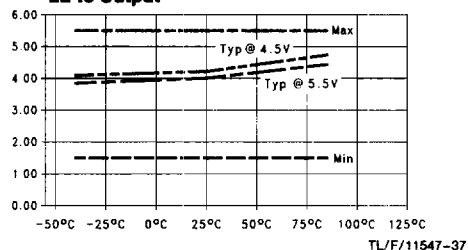

**$t_{PHL}$  vs Temperature ( $T_A$ )**  
 **$C_L = 50$  pF, 8 Outputs Switching**  
**LE to Output**

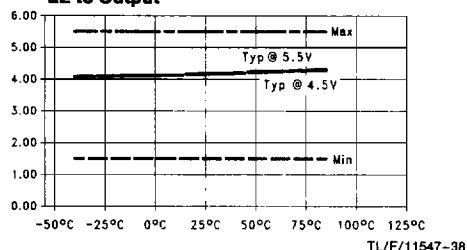

**$t_{PLH}$  and  $t_{PHL}$  vs Number Outputs Switching**  
 **$C_L = 50$  pF,  $T_A = 25^\circ\text{C}$ ,  $V_{CC} = 5.0\text{V}$ ,**  
**Outputs In Phase Data to Output**

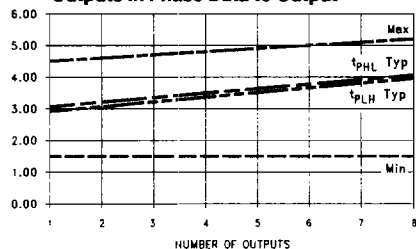

**Typical  $I_{CC}$  vs Output Switching Frequency**  
 **$C_L = 0$  pF,  $V_{CC} = V_{IH} = 5.5\text{V}$ , LE = GND,**  
**1 Output Switching at 50% Duty Cycle**  
**Data to Output, Transparent Mode with**  
**Unused Data Inputs =  $V_{IH}$**

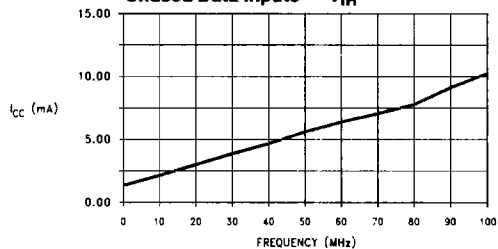

Dashed lines represent design characteristics; for specified guarantees, refer to AC Characteristics Tables.