



Integrated Device Technology, Inc.

FAST CMOS 16-BIT BUS TRANSCEIVER/ REGISTERS

IDT54/74FCT16652T/AT/CT/ET
IDT54/74FCT162652T/AT/CT/ET

FEATURES:

- **Common features:**
 - 0.5 MICRON CMOS Technology
 - **High-speed, low-power CMOS replacement for ABT functions**
 - **Typical tsk(o) (Output Skew) < 250ps**
 - **Low input and output leakage $\leq 1\mu A$ (max.)**
 - ESD > 2000V per MIL-STD-883, Method 3015; > 200V using machine model (C = 200pF, R = 0)
 - 25 mil Center SSOP and Cerpack Packages and 19.6 mil pitch TSSOP Package
 - Extended commercial range of -40°C to +85°C
 - Vcc = 5V $\pm 10\%$
- **Features for FCT16652T/AT/CT/ET:**
 - High drive outputs (-32mA IOH, 64mA IOL)
 - Power off disable outputs permit "live insertion"
 - Typical VOLP (Output Ground Bounce) < 1.0V at Vcc = 5V, TA = 25°C
- **Features for FCT162652T/AT/CT/ET:**
 - Balanced Output Drivers: $\pm 24mA$ (commercial), $\pm 16mA$ (military)
 - Reduced system switching noise
 - Typical VOLP (Output Ground Bounce) < 0.6V at Vcc = 5V, TA = 25°C

VICES are organized as two independent 8-bit bus transceivers with 3-state D-type registers. For example, the xOEAB and xOEBA signals control the transceiver functions.

The xSAB and xSBA control pins are provided to select either real time or stored data transfer. The circuitry used for select control will eliminate the typical decoding glitch that occurs in a multiplexer during the transition between stored and real time data. A LOW input level selects real-time data and a HIGH level selects stored data.

Data on the A or B data bus, or both, can be stored in the internal D-flip-flops by LOW-to-HIGH transitions at the appropriate clock pins (xCLKAB or xCLKBA), regardless of the select or enable control pins. Flow-through organization of signal pins simplifies layout. All inputs are designed with hysteresis for improved noise margin.

The FCT16652T/AT/CT/ET are ideally suited for driving high capacitance loads and low-impedance backplanes. The output buffers are designed with power off disable capability to allow "live insertion" of boards when used as backplane drivers.

The FCT162652T/AT/CT/ET have balanced output drive with current limiting resistors. This offers low ground bounce, minimal undershoot, and controlled output fall times—reducing the need for external series terminating resistors. The FCT162652T/AT/CT/ET are plug-in replacements for the FCT16652T/AT/CT/ET and ABT16652 for on-board bus interface applications.

5

DESCRIPTION:

The FCT16652T/AT/CT/ET and FCT162652T/AT/CT/ET 16-bit registered transceivers are built using advanced dual metal CMOS technology. These high-speed, low-power de-

FUNCTIONAL BLOCK DIAGRAM

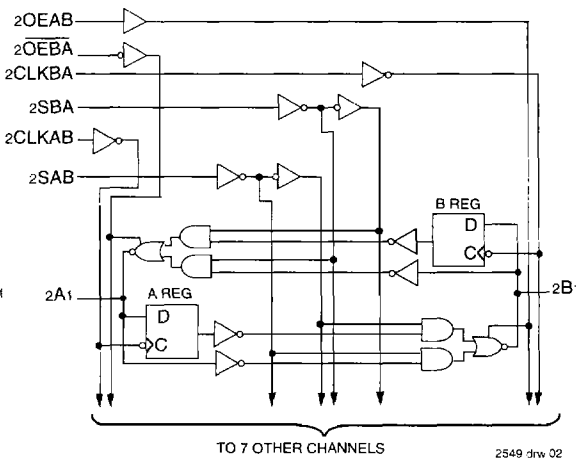
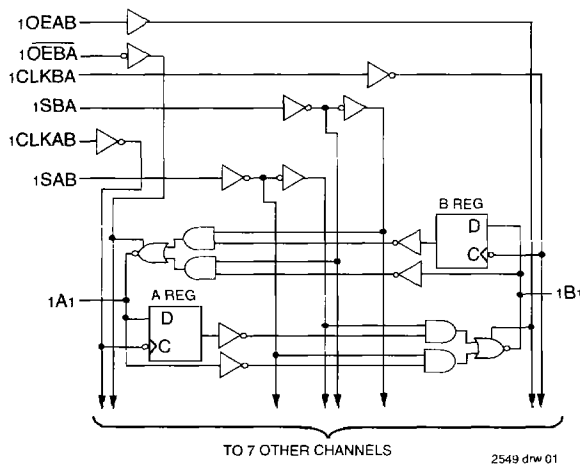

The IDT logo is a registered trademark of Integrated Device Technology, Inc.

MILITARY AND COMMERCIAL TEMPERATURE RANGES

JUNE 1996

PIN CONFIGURATIONS

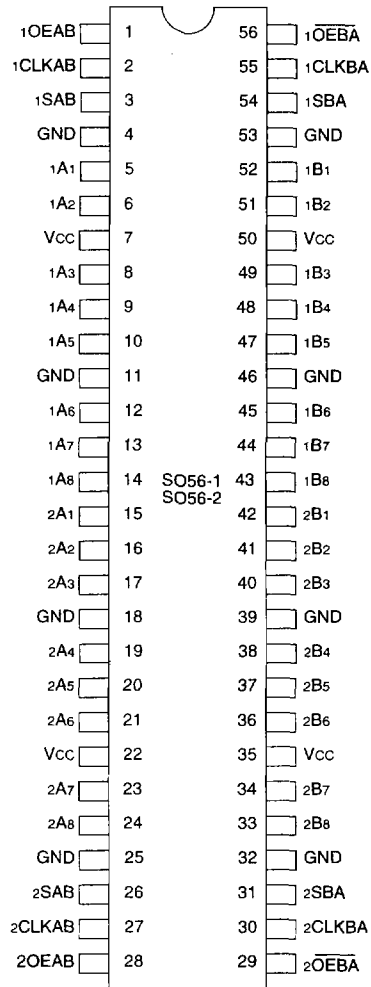

**SSOP/
TSSOP
TOP VIEW**

2549 drw 03

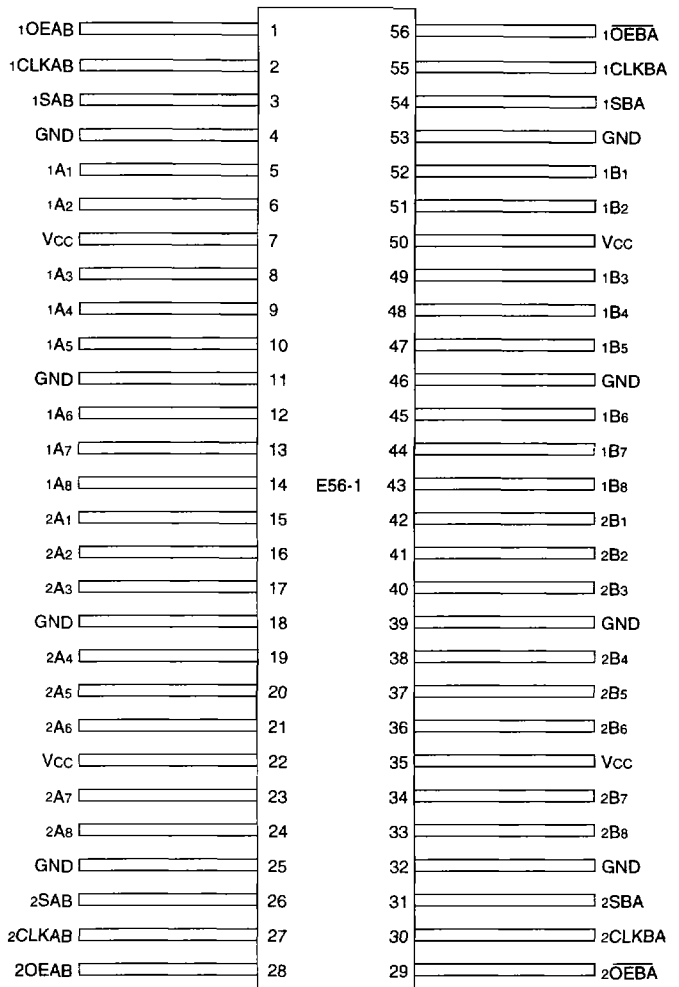

**CERPACK
TOP VIEW**

2549 drw 04

PIN DESCRIPTION

Pin Names	Description
xAx	Data Register A Inputs Data Register B Outputs
xBx	Data Register B Inputs Data Register A Outputs
xCLKAB, xCLKBA	Clock Pulse Inputs
xSAB, xSBA	Output Data Source Select Inputs
xOEAB, xOEBA	Output Enable Inputs

2549 tbl 01

CAPACITANCE (TA = +25°C, f = 1.0MHz)

Symbol	Parameter ⁽¹⁾	Conditions	Typ.	Max.	Unit
CIN	Input Capacitance	VIN = 0V	3.5	6.0	pF
CIO	I/O Capacitance	VOUT = 0V	3.5	8.0	pF

NOTE:

1. This parameter is measured at characterization but not tested.

2549 Ink 02

FUNCTION TABLE⁽²⁾

Inputs						Data I/O ⁽¹⁾		Operation or Function
xOEAB	xOEBA	xCLKAB	xCLKBA	xSAB	xSBA	xAx	xBx	
L	H	H or L	H or L	X	X	Input	Input	Isolation
L	H	↑	↑	X	X			Store A and B Data
X	H	↑	H or L	X	X	Input	Unspecified ⁽¹⁾	Store A, Hold B
H	H	↑	↑	X ⁽²⁾	X	Input	Output	Store A in Both Registers
L	X	H or L	↑	X	X	Unspecified ⁽¹⁾	Input	Hold A, Store B
L	L	↑	↑	X	X ⁽²⁾	Output	Input	Store B in both Registers
L	L	X	X	X	L	Output	Input	Real Time B Data to A Bus
L	L	X	H or L	X	H			Stored B Data to A Bus
H	H	X	X	L	X	Input	Output	Real Time A Data to B Bus
H	H	H or L	X	H	X			Stored A Data to B Bus
H	L	H or L	H or L	H	H	Output	Output	Stored A Data to B Bus and Stored B Data to A Bus

NOTES:

- The data output functions may be enabled or disabled by various signals at the xOEAB or xOEBA inputs. Data input functions are always enabled, i.e. data at the bus pins will be stored on every LOW-to-HIGH transition on the clock inputs.
- Select control = L: clocks can occur simultaneously.
Select control = H: clocks must be staggered to load both registers.
- H = HIGH Voltage Level
L = LOW Voltage Level
X = Don't Care
↑ = LOW-to-HIGH Transition

2549 tbl 03

ABSOLUTE MAXIMUM RATINGS⁽¹⁾

Symbol	Rating	Commercial	Military	Unit
VTERM ⁽²⁾	Terminal Voltage with Respect to GND	-0.5 to +7.0	-0.5 to +7.0	V
VTERM ⁽³⁾	Terminal Voltage with Respect to GND	-0.5 to VCC +0.5	-0.5 to VCC +0.5	V
TA	Operating Temperature	-40 to +85	-55 to +125	°C
TBIAS	Temperature Under Bias	-55 to +125	-65 to +135	°C
TSTG	Storage Temperature	-55 to +125	-65 to +150	°C
PT	Power Dissipation	1.0	1.0	W
IOUT	DC Output Current	-60 to +120	-60 to +120	mA

NOTES:

- Stresses greater than those listed under ABSOLUTE MAXIMUM RATINGS may cause permanent damage to the device. This is a stress rating only and functional operation of the device at these or any other conditions above those indicated in the operational sections of this specification is not implied. Exposure to absolute maximum rating conditions for extended periods may affect reliability.
- All device terminals except FCT162XXXT Output and I/O terminals.
- Output and I/O terminals for FCT162XXXT.

2549 tbl 04



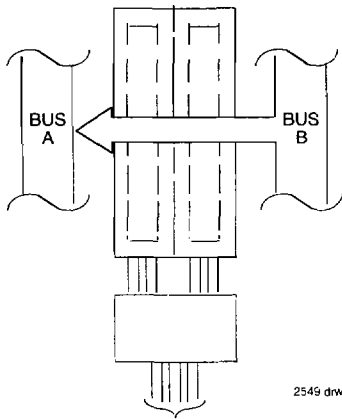

2549 drw 05

xOEAB	$\overline{\text{xOEBA}}$	xCLKAB	xCLKBA	xSAB	xSBA
L	L	X	X	X	L

**REAL-TIME TRANSFER
 BUS B TO A**

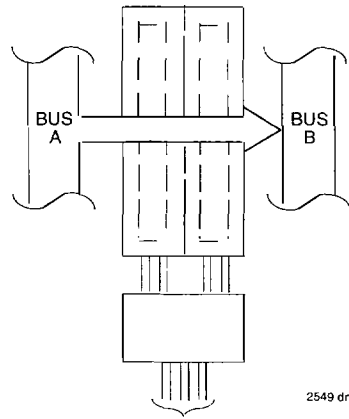

2549 drw 06

xOEAB	$\overline{\text{xOEBA}}$	xCLKAB	xCLKBA	xSAB	xSBA
H	H	X	X	L	X

**REAL-TIME TRANSFER
 BUS A TO B**

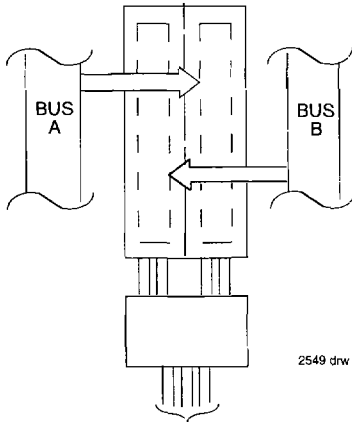

2549 drw 07

xOEAB	$\overline{\text{xOEBA}}$	xCLKAB	xCLKBA	xSAB	xSBA
X	H	↑	X	X	X
L	X	X	↑	X	X
L	H	↑	↑	X	X

**STORAGE FROM
 A AND/OR B**

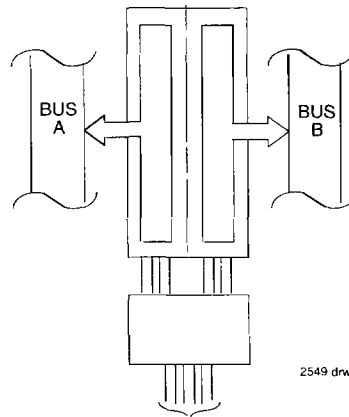

2549 drw 08

xOEAB	$\overline{\text{xOEBA}}$	xCLKAB	xCLKBA	xSAB	xSBA
H	L	H or L	H or L	H	H

**TRANSFER STORED
 DATA TO A AND/OR B**

DC ELECTRICAL CHARACTERISTICS OVER OPERATING RANGE

Following Conditions Apply Unless Otherwise Specified:

Commercial: TA = -40°C to +85°C, VCC = 5.0V ± 10%; Military: TA = -55°C to +125°C, VCC = 5.0V ± 10%

Symbol	Parameter	Test Conditions ⁽¹⁾		Min.	Typ. ⁽²⁾	Max.	Unit
V _{IH}	Input HIGH Level	Guaranteed Logic HIGH Level		2.0	—	—	V
V _{IL}	Input LOW Level	Guaranteed Logic LOW Level		—	—	0.8	V
I _{IH}	Input HIGH Current (Input pins) ⁽⁵⁾	V _{CC} = Max.	V _I = V _{CC}	—	—	±1	μA
	Input HIGH Current (I/O pins) ⁽⁵⁾			—	—	±1	
I _{IL}	Input LOW Current (Input pins) ⁽⁵⁾		V _I = GND	—	—	±1	
	Input LOW Current (I/O pins) ⁽⁵⁾			—	—	±1	
I _{OZH}	High Impedance Output Current (3-State Output pins) ⁽⁵⁾	V _{CC} = Max.	V _O = 2.7V	—	—	±1	μA
I _{OZL}			V _O = 0.5V	—	—	±1	
V _{IK}	Clamp Diode Voltage	V _{CC} = Min., I _{IN} = -18mA		—	-0.7	-1.2	V
I _{OS}	Short Circuit Current	V _{CC} = Max., V _O = GND ⁽³⁾		-80	-140	-225	mA
V _H	Input Hysteresis	—		—	100	—	mV
I _{CC1} I _{CC2} I _{CC3}	Quiescent Power Supply Current	V _{CC} = Max., V _{IN} = GND or V _{CC}		—	5	500	μA

2549 Ink 05

OUTPUT DRIVE CHARACTERISTICS FOR FCT16652T

Symbol	Parameter	Test Conditions ⁽¹⁾		Min.	Typ. ⁽²⁾	Max.	Unit
I _O	Output Drive Current	V _{CC} = Max., V _O = 2.5V ⁽³⁾		-50	—	-180	mA
V _{OH}	Output HIGH Voltage	V _{CC} = Min. V _{IN} = V _{IH} or V _{IL}	I _{OH} = -3mA	2.5	3.5	—	V
			I _{OH} = -12mA MIL. I _{OH} = -15mA COM'L.	2.4	3.5	—	V
			I _{OH} = -24mA MIL. I _{OH} = -32mA COM'L. ⁽⁴⁾	2.0	3.0	—	V
			I _{OL} = 48mA MIL. I _{OL} = 64mA COM'L.	—	0.2	0.55	V
V _{OL}	Output LOW Voltage	V _{CC} = Min. V _{IN} = V _{IH} or V _{IL}	I _{OL} = 48mA MIL. I _{OL} = 64mA COM'L.	—	0.2	0.55	V
I _{OFF}	Input/Output Power Off Leakage ⁽⁵⁾	V _{CC} = 0V, V _{IN} or V _O ≤ 4.5V		—	—	±1	μA

2549 Ink 06

OUTPUT DRIVE CHARACTERISTICS FOR FCT162652T

Symbol	Parameter	Test Conditions ⁽¹⁾		Min.	Typ. ⁽²⁾	Max.	Unit
I _{ODL}	Output LOW Current	V _{CC} = 5V, V _{IN} = V _{IH} or V _{IL} , V _{OUT} = 1.5V ⁽³⁾		60	115	200	mA
I _{ODH}	Output HIGH Current	V _{CC} = 5V, V _{IN} = V _{IH} or V _{IL} , V _{OUT} = 1.5V ⁽³⁾		-60	-115	-200	mA
V _{OH}	Output HIGH Voltage	V _{CC} = Min. V _{IN} = V _{IH} or V _{IL}	I _{OH} = -16mA MIL. I _{OH} = -24mA COM'L.	2.4	3.3	—	V
			I _{OL} = 16mA MIL. I _{OL} = 24mA COM'L.	—	0.3	0.55	V
V _{OL}	Output LOW Voltage	V _{CC} = Min. V _{IN} = V _{IH} or V _{IL}	I _{OL} = 16mA MIL. I _{OL} = 24mA COM'L.	—	0.3	0.55	V

2549 Ink 07

NOTES:

- For conditions shown as Max. or Min., use appropriate value specified under Electrical Characteristics for the applicable device type.
- Typical values are at V_{CC} = 5.0V, +25°C ambient.
- Not more than one output should be tested at one time. Duration of the test should not exceed one second.
- Duration of the condition can not exceed one second.
- The test limit for this parameter is ±5μA at TA = -55°C.

POWER SUPPLY CHARACTERISTICS

	Parameter	Test Conditions ⁽¹⁾	Min.	Typ. ⁽²⁾	Max.	Unit	
ΔI_{CC}	Quiescent Power Supply Current TTL Inputs HIGH	$V_{CC} = \text{Max.}$ $V_{IN} = 3.4V^{(3)}$	—	0.5	1.5	mA	
I_{CCD}	Dynamic Power Supply Current ⁽⁴⁾	$V_{CC} = \text{Max.}$ Outputs Open $xOEAB = x\overline{OEBA} = GND$ One Input Toggling 50% Duty Cycle	$V_{IN} = V_{CC}$ $V_{IN} = GND$	75	120	$\mu A/$ MHz	
I_C	Total Power Supply Current ⁽⁶⁾	$V_{CC} = \text{Max.}$ Outputs Open $f_{CP} = 10\text{MHz}$ ($xCLKBA$) 50% Duty Cycle $xOEAB = x\overline{OEBA} = GND$ One Bit Toggling $f_i = 5\text{MHz}$ 50% Duty Cycle	$V_{IN} = V_{CC}$ $V_{IN} = GND$	—	0.8	1.7	mA
		$V_{CC} = \text{Max.}$ Outputs Open $f_{CP} = 10\text{MHz}$ ($xCLKBA$) 50% Duty Cycle $xOEAB = x\overline{OEBA} = GND$ One Bit Toggling $f_i = 5\text{MHz}$ 50% Duty Cycle	$V_{IN} = 3.4V$ $V_{IN} = GND$	—	1.3	3.2	
		$V_{CC} = \text{Max.}$ Outputs Open $f_{CP} = 10\text{MHz}$ ($xCLKBA$) 50% Duty Cycle $xOEAB = x\overline{OEBA} = GND$ Sixteen Bits Toggling $f_i = 2.5\text{MHz}$ 50% Duty Cycle	$V_{IN} = V_{CC}$ $V_{IN} = GND$	—	3.8	6.5 ⁽⁵⁾	
		$V_{CC} = \text{Max.}$ Outputs Open $f_{CP} = 10\text{MHz}$ ($xCLKBA$) 50% Duty Cycle $xOEAB = x\overline{OEBA} = GND$ Sixteen Bits Toggling $f_i = 2.5\text{MHz}$ 50% Duty Cycle	$V_{IN} = 3.4V$ $V_{IN} = GND$	—	8.3	20.0 ⁽⁵⁾	

NOTES:

2549 tbt 08

- For conditions shown as Max. or Min., use appropriate value specified under Electrical Characteristics for the applicable device type.
- Typical values are at $V_{CC} = 5.0V$, $+25^\circ C$ ambient.
- Per TTL driven input ($V_{IN} = 3.4V$). All other inputs at V_{CC} or GND .
- This parameter is not directly testable, but is derived for use in Total Power Supply Calculations.
- Values for these conditions are examples of the I_{CC} formula. These limits are guaranteed but not tested.
- $I_C = I_{QUIESCENT} + I_{INPUTS} + I_{DYNAMIC}$
 $I_C = I_{CC} + \Delta I_{CC} D_H N_T + I_{CCD} (f_{CP} N_{CP} / 2 + f_i N_i)$
 $I_{CC} = \text{Quiescent Current (} I_{CCL}, I_{CCH} \text{ and } I_{CCZ} \text{)}$
 $\Delta I_{CC} = \text{Power Supply Current for a TTL High Input (} V_{IN} = 3.4V \text{)}$
 $D_H = \text{Duty Cycle for TTL Inputs High}$
 $N_T = \text{Number of TTL Inputs at } D_H$
 $I_{CCD} = \text{Dynamic Current Caused by an Input Transition Pair (HLH or LHL)}$
 $f_{CP} = \text{Clock Frequency for Register Devices (Zero for Non-Register Devices)}$
 $N_{CP} = \text{Number of Clock Inputs at } f_{CP}$
 $f_i = \text{Input Frequency}$
 $N_i = \text{Number of Inputs at } f_i$

SWITCHING CHARACTERISTICS OVER OPERATING RANGE

Symbol	Parameter	Condition ⁽¹⁾	FCT16652T/162652T				FCT16652AT/162652AT				Unit
			Com'l.		Mil.		Com'l.		Mil.		
			Min. ⁽²⁾	Max.	Min. ⁽²⁾	Max.	Min. ⁽²⁾	Max.	Min. ⁽²⁾	Max.	
tPLH tPHL	Propagation Delay Bus to Bus	CL = 50pF RL = 500Ω	2.0	9.0	2.0	11.0	2.0	6.3	2.0	7.7	ns
tPZH tPZL	Output Enable Time xOEAB or xOEBA to Bus		2.0	14.0	2.0	15.0	2.0	9.8	2.0	10.5	ns
tPHZ tPLZ	Output Disable Time xOEAB or xOEBA to Bus		2.0	9.0	2.0	11.0	2.0	6.3	2.0	7.7	ns
tPLH tPHL	Propagation Delay Clock to Bus		2.0	9.0	2.0	10.0	2.0	6.3	2.0	7.0	ns
tPLH tPHL	Propagation Delay xSBA or xSAB to Bus		2.0	11.0	2.0	12.0	2.0	7.7	2.0	8.4	ns
tsu	Set-up Time HIGH or LOW Bus to Clock		4.0	—	4.5	—	2.0	—	2.0	—	ns
th	Hold Time HIGH or LOW Bus to Clock		2.0	—	2.0	—	1.5	—	1.5	—	ns
tw	Clock Pulse Width HIGH or LOW		6.0	—	6.0	—	5.0	—	5.0	—	ns
tsk(o)	Output Skew ⁽³⁾		—	0.5	—	0.5	—	0.5	—	0.5	ns

2549 tbl 09



Symbol	Parameter	Condition ⁽¹⁾	FCT16652CT/162652CT				FCT16652ET/162652ET				Unit
			Com'l.		Mil.		Com'l.		Mil.		
			Min. ⁽²⁾	Max.	Min. ⁽²⁾	Max.	Min. ⁽²⁾	Max.	Min. ⁽²⁾	Max.	
tPLH tPHL	Propagation Delay Bus to Bus	CL = 50pF RL = 500Ω	1.5	5.4	1.5	6.0	1.5	3.8	—	—	ns
tPZH tPZL	Output Enable Time xOEAB or xOEBA to Bus		1.5	7.8	1.5	8.9	1.5	4.8	—	—	ns
tPHZ tPLZ	Output Disable Time xOEAB or xOEBA to Bus		1.5	6.3	1.5	7.7	1.5	4.0	—	—	ns
tPLH tPHL	Propagation Delay Clock to Bus		1.5	5.7	1.5	6.3	1.5	3.8	—	—	ns
tPLH tPHL	Propagation Delay xSBA or xSAB to Bus		1.5	6.2	1.5	7.0	1.5	4.2	—	—	ns
tsu	Set-up Time HIGH or LOW Bus to Clock		2.0	—	2.0	—	2.0	—	—	—	ns
th	Hold Time HIGH or LOW Bus to Clock		1.5	—	1.5	—	0.0	—	—	—	ns
tw	Clock Pulse Width HIGH or LOW		5.0	—	5.0	—	3.0 ⁽⁴⁾	—	—	—	ns
tsk(o)	Output Skew ⁽³⁾		—	0.5	—	0.5	—	0.5	—	—	ns

2549 tbl 10

NOTES:

1. See test circuit and waveforms.
2. Minimum limits are guaranteed but not tested on Propagation Delays.
3. Skew between any two outputs of the same package switching in the same direction. This parameter is guaranteed by design.
4. This limit is guaranteed but not tested.

TEST CIRCUITS AND WAVEFORMS

TEST CIRCUITS FOR ALL OUTPUTS

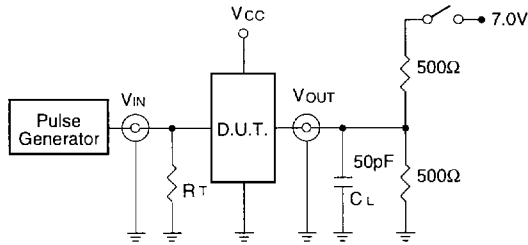

2549 drw 05

SWITCH POSITION

Test	Switch
Open Drain Disable Low Enable Low	Closed
All Other Tests	Open

DEFINITIONS:

CL = Load capacitance: includes jig and probe capacitance.

R_T = Termination resistance: should be equal to Z_{OUT} of the Pulse Generator.

2549 Ink 10

SET-UP, HOLD AND RELEASE TIMES

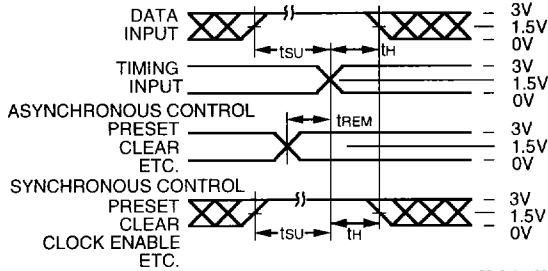

2549 drw 06

PULSE WIDTH

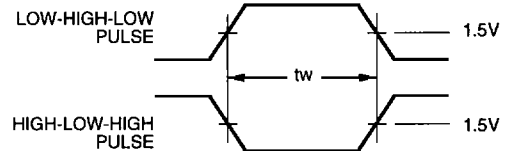

2549 drw 07

PROPAGATION DELAY

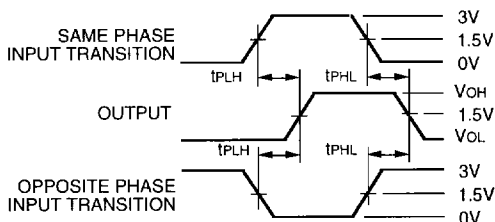

2549 drw 08

ENABLE AND DISABLE TIMES

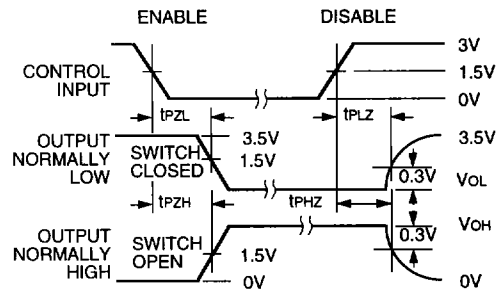

2549 drw 09

NOTES:

1. Diagram shown for input Control Enable-LOW and input Control Disable-HIGH
2. Pulse Generator for All Pulses: Rate ≤ 1.0MHz; tr ≤ 2.5ns; th ≤ 2.5ns

ORDERING INFORMATION

IDT	<u>XX</u>	FCT	<u>XXXX</u>	<u>X</u>	<u>X</u>
	Temperature		Device Type	Package	Process
	Range				

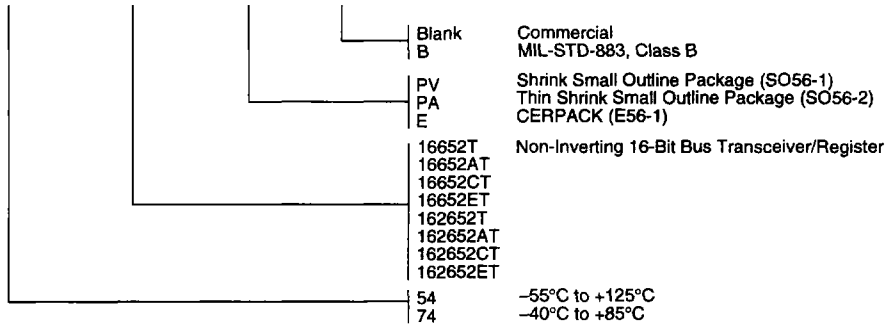

2549 drw 14

