

74F00 Quad 2-Input NAND Gate

General Description

This device contains four independent gates, each of which performs the logic NAND function.

Features

- Guaranteed 4000V minimum ESD protection

Ordering Code:

Commercial	Military	Package Number	Package Description
74F00PC		N14A	14-Lead (0.300" Wide) Molded Dual-In-Line
	54F00DM (Note 2)	J14A	14-Lead Ceramic Dual-In-Line
74F00SC (Note 1)		M14A	14-Lead (0.150" Wide) Molded Small Outline, JEDEC
74F00SJ (Note 1)		M14D	14-Lead (0.300" Wide) Molded Small Outline, EIAJ
	54F00FM (Note 2)	W14B	14-Lead Cerpack
	54F00LM (Note 2)	E20A	20-Lead Ceramic Leadless Chip Carrier, Type C

Note 1: Devices also available in 13" reel. Use suffix = SCX and SJX

Note 2: Military grade device with environmental and burn-in processing. Use suffix = DMQB, FMQB and LMQB

Logic Symbol

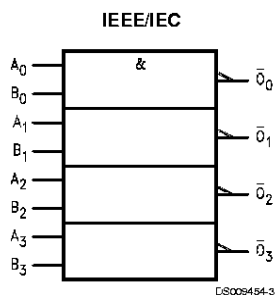

Connection Diagrams

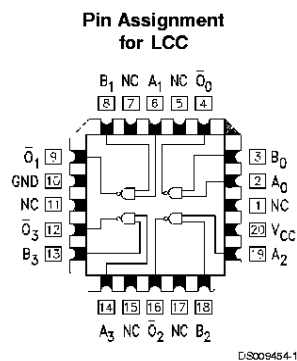
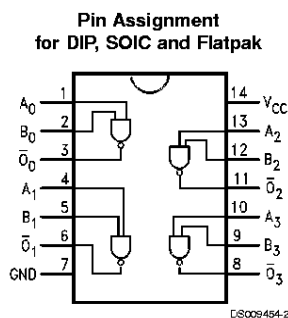

Unit Loading/Fan Out

Pin Names	Description	54F/74F	
		U.L. HIGH/LOW	Input I_{IH}/I_{IL} Output I_{OH}/I_{OL}
A_n, B_n	Inputs	1.0/1.0	20 μ A/-0.6 mA
\overline{O}_n	Outputs	50/33.3	-1 mA/20 mA

Absolute Maximum Ratings (Note 3)

Storage Temperature	-65°C to +150°C
Ambient Temperature under Bias	-55°C to +125°C
Junction Temperature under Bias	-55°C to +175°C
Plastic	-55°C to +150°C
V _{CC} Pin Potential to Ground Pin	-0.5V to +7.0V
Input Voltage (Note 4)	-0.5V to +7.0V
Input Current (Note 4)	-30 mA to +5.0 mA
Voltage Applied to Output in HIGH State (with V _{CC} = 0V)	
Standard Output	-0.5V to V _{CC}
3-STATE Output	-0.5V to +5.5V
Current Applied to Output	

in LOW State (Max) twice the rated I_{OL} (mA)
ESD Last Passing Voltage (Min) 4000V

Recommended Operating Conditions

Free Air Ambient Temperature	
Commercial	0°C to +70°C
Supply Voltage	
Commercial	+4.5V to +5.5V

Note 3: Absolute maximum ratings are values beyond which the device may be damaged or have its useful life impaired. Functional operation under these conditions is not implied.

Note 4: Either voltage limit or current limit is sufficient to protect inputs.

DC Electrical Characteristics

Symbol	Parameter	54F/74F			Units	V _{CC}	Conditions
		Min	Typ	Max			
V _{IH}	Input HIGH Voltage	2.0			V		Recognized as a HIGH Signal
V _{IL}	Input LOW Voltage				V		Recognized as a LOW Signal
V _{CD}	Input Clamp Diode Voltage				V	Min	I _{IN} = -18 mA
V _{OH}	Output HIGH Voltage	54F 10% V _{CC}	2.5		V	Min	I _{OH} = -1 mA
		74F 10% V _{CC}	2.5				I _{OH} = -1 mA
		74F 5% V _{CC}	2.7				I _{OH} = -1 mA
V _{OL}	Output LOW Voltage	54F 10% V _{CC}			V	Min	I _{OL} = 20 mA
		74F 10% V _{CC}					I _{OL} = 20 mA
I _{IH}	Input HIGH Current	54F	20.0		μA	Max	V _{IN} = 2.7V
		74F	5.0				
I _{BVI}	Input HIGH Current Breakdown Test	54F	100		μA	Max	V _{IN} = 7.0V
		74F	7.0				
I _{CEX}	Output HIGH Leakage Current	54F	250		μA	Max	V _{OUT} = V _{CC}
		74F	50				
V _{ID}	Input Leakage Test	74F	4.75		V	0.0	I _{ID} = 1.9 μA All other pins grounded
I _{OD}	Output Leakage Circuit Current	74F	3.75		μA	0.0	V _{IOD} = 150 mV All other pins grounded
I _{IL}	Input LOW Current				mA	Max	V _{IN} = 0.5V
I _{OS}	Output Short-Circuit Current	-60			mA	Max	V _{OUT} = 0V
I _{CCH}	Power Supply Current	1.9			mA	Max	V _O = HIGH
I _{CCL}	Power Supply Current	6.8			mA	Max	V _O = LOW

AC Electrical Characteristics

Symbol	Parameter	74F			54F		74F		Units
		T _A = +25°C V _{CC} = +5.0V C _L = 50 pF			T _A , V _{CC} = MII C _L = 50 pF		T _A , V _{CC} = Com C _L = 50 pF		
		Min	Typ	Max	Min	Max	Min	Max	
t _{PLH}	Propagation Delay	2.4	3.7	5.0	2.0	7.0	2.4	6.0	ns
t _{PHL}	A _n , B _n to \bar{O}_n	1.5	3.2	4.3	1.5	6.5	1.5	5.3	

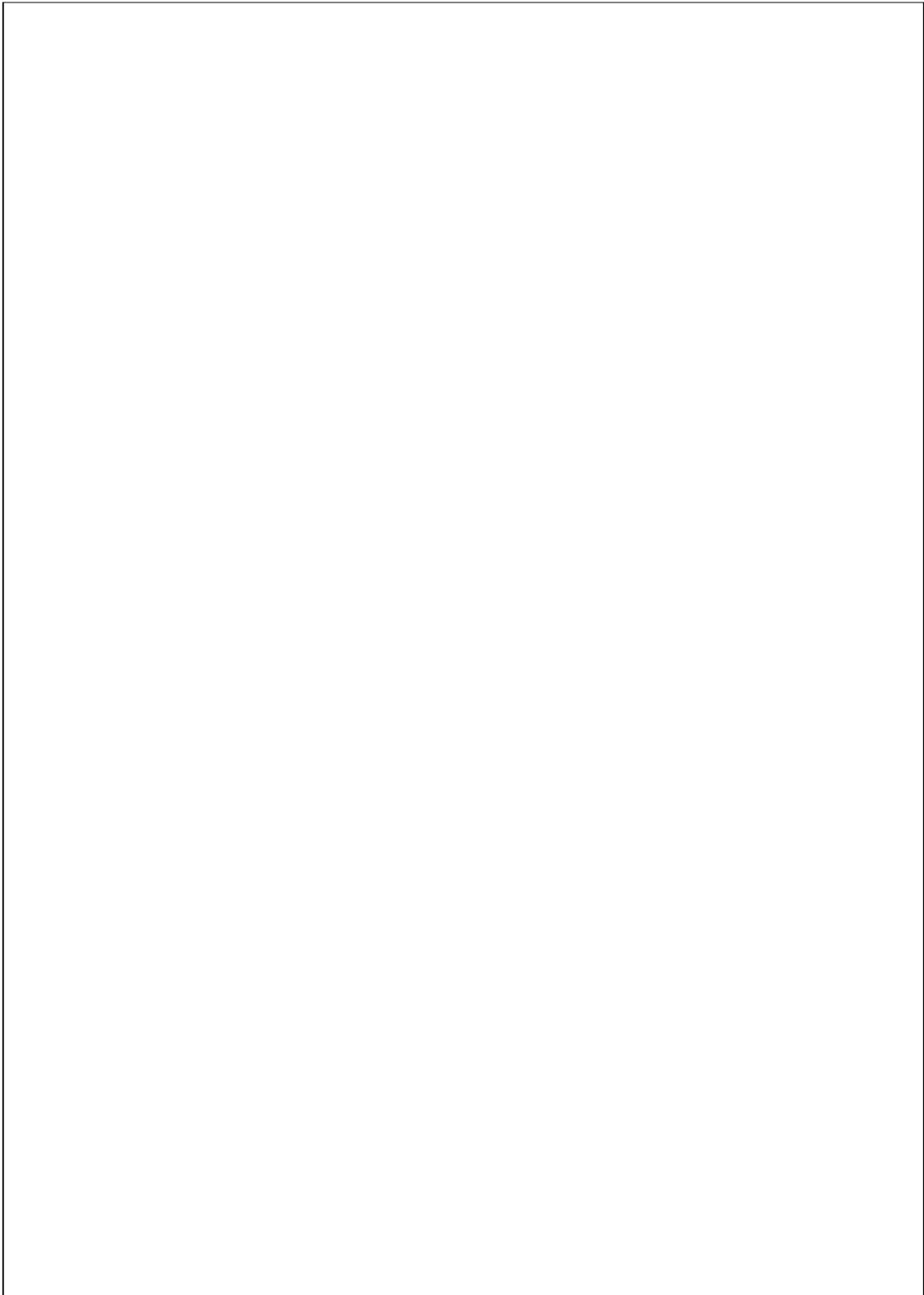

Ordering Information

The device number is used to form part of a simplified purchasing code where the package type and temperature range are defined as follows:

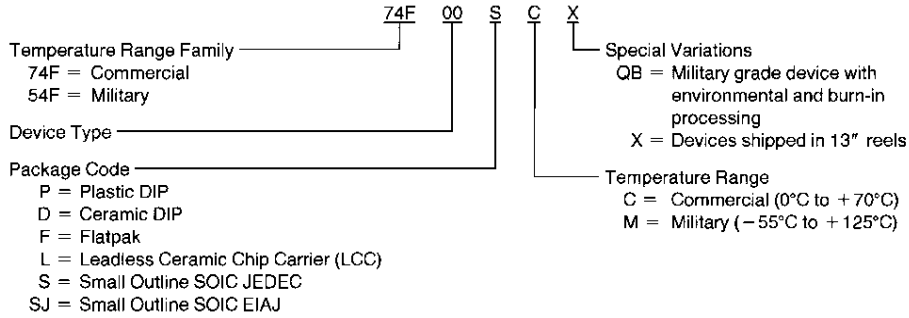

D8009454-4

Physical Dimensions inches (millimeters) unless otherwise noted

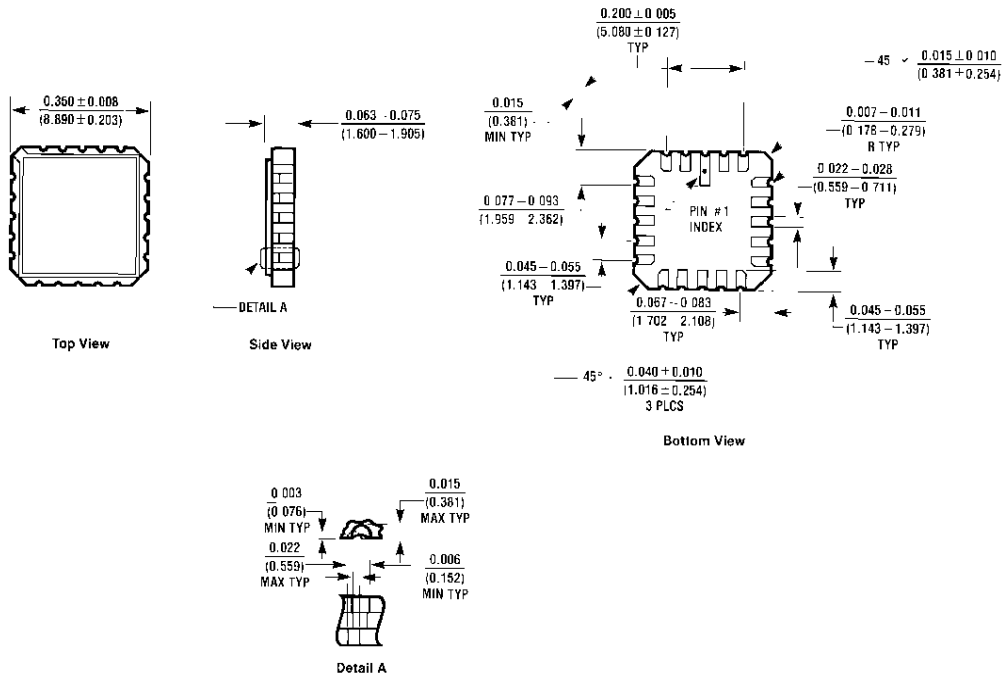

E0-AIRBY-1

**20-Lead Ceramic Leadless Chip Carrier (L)
 NS Package Number E20A**

Physical Dimensions inches (millimeters) unless otherwise noted (Continued)

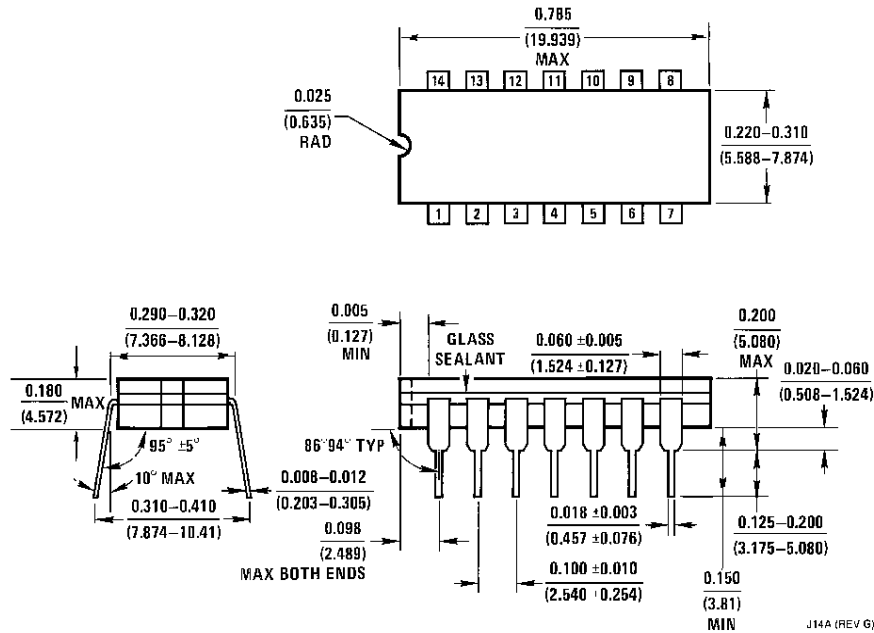

14-Lead Ceramic Dual-In-Line Package (D)
NS Package Number J14A

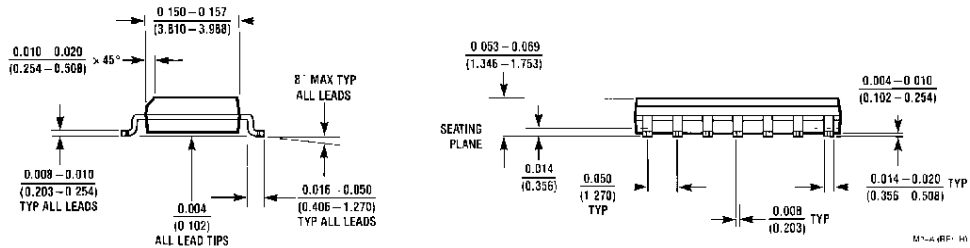
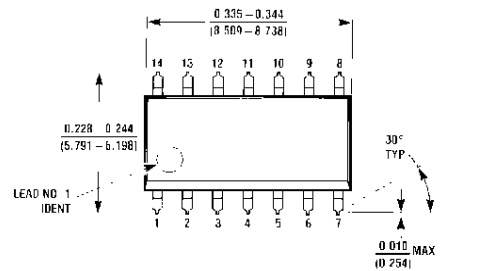

14-Lead (0.150" Wide) Molded Small Outline Package, JEDEC (S)
NS Package Number M14A

Physical Dimensions inches (millimeters) unless otherwise noted (Continued)

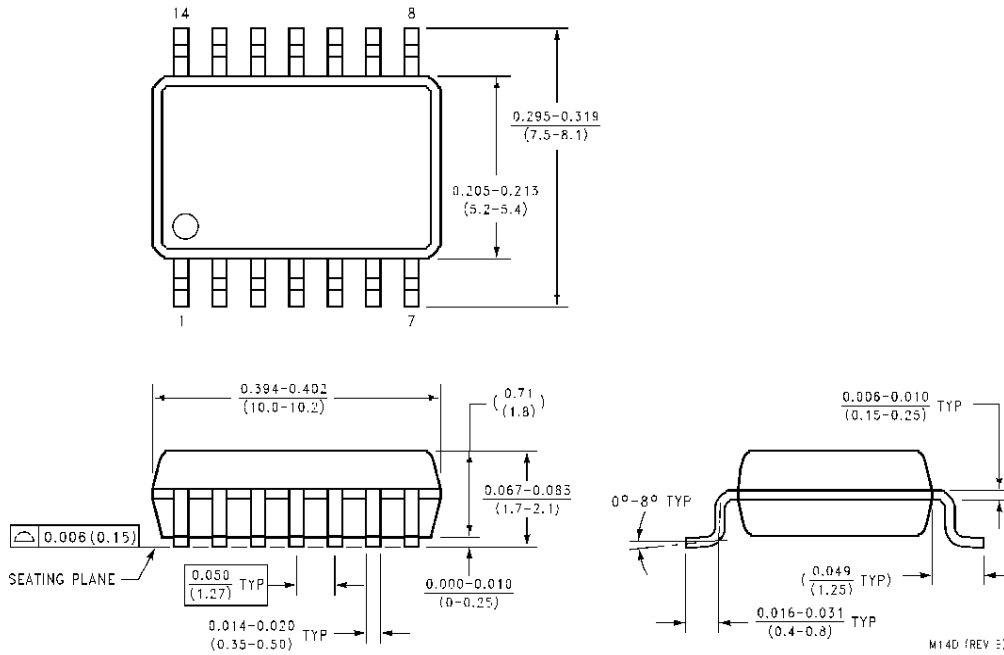

**14-Lead (0.300" Wide) Molded Small Outline Package, EIAJ (SJ)
NS Package Number M14D**

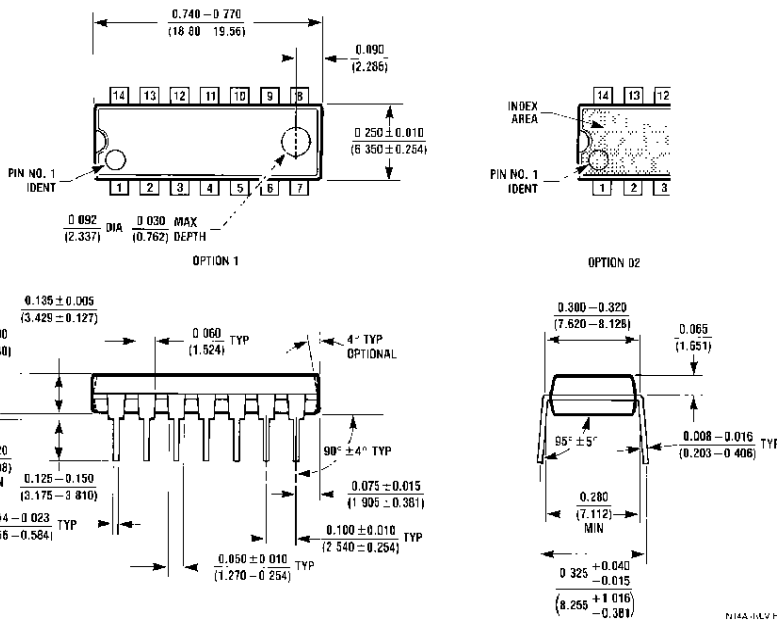

**14-Lead (0.300" Wide) Molded Dual-In-Line Package (P)
NS Package Number N14A**

Physical Dimensions inches (millimeters) unless otherwise noted (Continued)

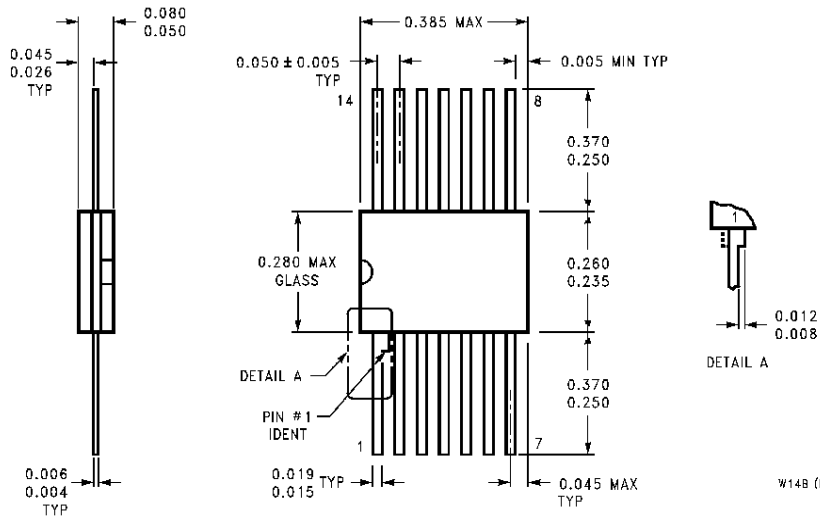

**14-Lead Ceramic Flatpak (F)
NS Package Number W14B**

LIFE SUPPORT POLICY

FAIRCHILD'S PRODUCTS ARE NOT AUTHORIZED FOR USE AS CRITICAL COMPONENTS IN LIFE SUPPORT DEVICES OR SYSTEMS WITHOUT THE EXPRESS WRITTEN APPROVAL OF THE PRESIDENT OF FAIRCHILD SEMICONDUCTOR CORPORATION. As used herein:

1. Life support devices or systems are devices or systems which, (a) are intended for surgical implant into the body, or (b) support or sustain life, and (c) whose failure to perform when properly used in accordance with instructions for use provided in the labeling, can be reasonably expected to result in a significant injury to the user.
2. A critical component in any component of a life support device or system whose failure to perform can be reasonably expected to cause the failure of the life support device or system, or to affect its safety or effectiveness.

Fairchild Semiconductor
Corporation
Americas
Customer Response Center
Tel 1-888-522-5372

www.fairchildsemi.com

Fairchild Semiconductor
Europe
Fax +49 (0) 1 80-530 85 86
Email europe.support@nsc.com
Deutsch Tel +49 (0) 6 141-35-0
English Tel +44 (0) 1 793-85-66-56
Italy Tel +39 (0) 2 57 5631

Fairchild Semiconductor
Hong Kong Ltd.
13th Floor, Straight Block,
Ocean Centre, 5 Canton Rd
Tsimshatsui, Kowloon
Hong Kong
Tel +852 2737-7200
Fax +852 2314-0061

National Semiconductor
Japan Ltd.
Tel 81-3-5620-6175
Fax 81-3-5620-6179