

SN54ALS1034, SN54AS1034A, SN74ALS1034, SN74AS1034A HEX DRIVERS

SDAS053B – APRIL 1982 – REVISED JANUARY 1995

- AS1034A Offer High Capacitive-Drive Capability
- Noninverting Drivers
- Package Options Include Plastic Small-Outline (D) Packages, Ceramic Chip Carriers (FK), and Standard Plastic (N) and Ceramic (J) 300-mil DIPs

description

These devices contain six independent noninverting drivers. They perform the Boolean function $Y = A$.

The SN54ALS1034 and SN54AS1034A are characterized for operation over the full military temperature range of -55°C to 125°C . The SN74ALS1034 and SN74AS1034A are characterized for operation from 0°C to 70°C .

FUNCTION TABLE
(each buffer)

| INPUT A | OUTPUT Y |
|------------|-------------|
| H | H |
| L | L |

logic symbol†

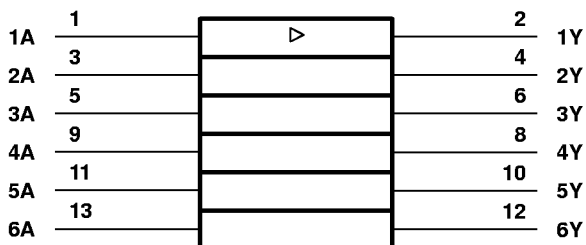

† This symbol is in accordance with ANSI/IEEE Std 91-1984 and IEC Publication 617-12.

Pin numbers shown are for the D, J, and N packages.

SN54ALS1034, SN54AS1034A . . . J PACKAGE
SN74ALS1034, SN74AS1034A . . . D OR N PACKAGE
(TOP VIEW)

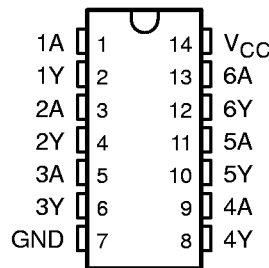

SN54ALS1034, SN54AS1034A . . . FK PACKAGE
(TOP VIEW)

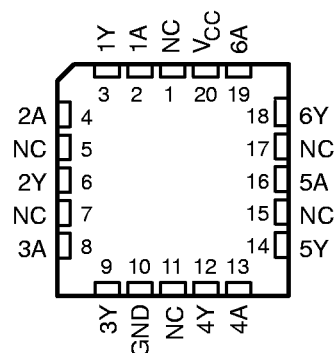

NC – No internal connection

logic diagram (positive logic)

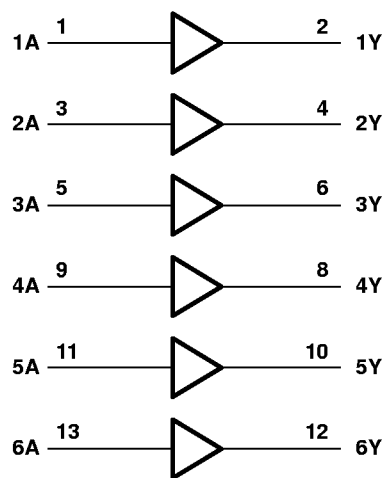

SN54ALS1034, SN54AS1034A, SN74ALS1034, SN74AS1034A HEX DRIVERS

SDAS053B – APRIL 1982 – REVISED JANUARY 1995

absolute maximum ratings over operating free-air temperature range (unless otherwise noted)†

| | |
|---|----------------|
| Supply voltage, V_{CC} | 7 V |
| Input voltage, V_I | 7 V |
| Operating free-air temperature range, T_A : SN54ALS1034 | -55°C to 125°C |
| SN74ALS1034 | 0°C to 70°C |
| Storage temperature range | -65°C to 150°C |

† Stresses beyond those listed under “absolute maximum ratings” may cause permanent damage to the device. These are stress ratings only, and functional operation of the device at these or any other conditions beyond those indicated under “recommended operating conditions” is not implied. Exposure to absolute-maximum-rated conditions for extended periods may affect device reliability.

recommended operating conditions

| | | SN54ALS1034 | | | SN74ALS1034 | | | UNIT |
|----------|--------------------------------|-------------|-----|-----|-------------|-----|-----|------|
| | | MIN | NOM | MAX | MIN | NOM | MAX | |
| V_{CC} | Supply voltage | 4.5 | 5 | 5.5 | 4.5 | 5 | 5.5 | V |
| V_{IH} | High-level input voltage | 2 | | | 2 | | | V |
| V_{IL} | Low-level input voltage | | | 0.7 | | | 0.8 | V |
| I_{OH} | High-level output current | | | -12 | | | -15 | mA |
| I_{OL} | Low-level output current | | | 12 | | | 24 | mA |
| T_A | Operating free-air temperature | -55 | | 125 | 0 | | 70 | °C |

electrical characteristics over recommended operating free-air temperature range (unless otherwise noted)

| PARAMETER | TEST CONDITIONS | SN54ALS1034 | | | SN74ALS1034 | | | UNIT |
|---------------|---|--------------------------|------|------|--------------|------|------|------|
| | | MIN | TYP‡ | MAX | MIN | TYP‡ | MAX | |
| V_{IK} | $V_{CC} = 4.5\text{ V}$, $I_I = -18\text{ mA}$ | | | -1.2 | | | -1.2 | V |
| V_{OH} | $V_{CC} = 4.5\text{ V to } 5.5\text{ V}$, $I_{OH} = -0.4\text{ mA}$ | $V_{CC} - 2$ | | | $V_{CC} - 2$ | | | V |
| | $V_{CC} = 4.5\text{ V}$ | $I_{OH} = -3\text{ mA}$ | 2.4 | 3.2 | 2.4 | 3.2 | | |
| | | $I_{OH} = -12\text{ mA}$ | 2 | | | | | |
| V_{OL} | $V_{CC} = 4.5\text{ V}$ | $I_{OH} = -15\text{ mA}$ | 2 | | | | | |
| | | $I_{OL} = 12\text{ mA}$ | 0.25 | 0.4 | | | V | |
| | | $I_{OL} = 24\text{ mA}$ | | | 0.35 | 0.5 | | |
| I_I | $V_{CC} = 5.5\text{ V}$, $V_I = 7\text{ V}$ | | | 0.1 | | | 0.1 | mA |
| I_{IH} | $V_{CC} = 5.5\text{ V}$, $V_I = 2.7\text{ V}$ | | | 20 | | | 20 | μA |
| I_{IL} | $V_{CC} = 5.5\text{ V}$, $V_I = 0.4\text{ V}$ | | | -0.1 | | | -0.1 | mA |
| I_{OS}^{\S} | $V_{CC} = 5.5\text{ V}$, $V_O = 2.25\text{ V}$ | -20 | | -112 | -30 | | -112 | mA |
| I_{CCH} | $V_{CC} = 5.5\text{ V}$, $V_I = 4.5\text{ V}$ | | 3 | 6 | | 3 | 6 | mA |
| I_{CCL} | $V_{CC} = 5.5\text{ V}$, $V_I = 0$ | | 8 | 14 | | 8 | 14 | mA |

‡ All typical values are at $V_{CC} = 5\text{ V}$, $T_A = 25^\circ\text{C}$.

§ The output conditions have been chosen to produce a current that closely approximates one half of the true short-circuit output current, I_{OS} .



SN54ALS1034, SN54AS1034A, SN74ALS1034, SN74AS1034A HEX DRIVERS

SDAS053B – APRIL 1982 – REVISED JANUARY 1995

switching characteristics (see Figure 1)

| PARAMETER | FROM (INPUT) | TO (OUTPUT) | V _{CC} = 4.5 V to 5.5 V, C _L = 50 pF, R _L = 500 Ω, T _A = MIN to MAX† | | | | UNIT |
|------------------|-----------------|----------------|---|-----|-------------|-----|------|
| | | | SN54ALS1034 | | SN74ALS1034 | | |
| | | | MIN | MAX | MIN | MAX | |
| t _{PLH} | A | Y | 1 | 11 | 1 | 8 | ns |
| t _{PHL} | | | 1 | 13 | 1 | 8 | |

† For conditions shown as MIN or MAX, use the appropriate value specified under recommended operating conditions.

absolute maximum ratings over operating free-air temperature range (unless otherwise noted) ‡

| | |
|--|----------------|
| Supply voltage, V _{CC} | 7 V |
| Input voltage, V _I | 7 V |
| Operating free-air temperature range, T _A : SN54AS1034A | –55°C to 125°C |
| SN74AS1034A | 0°C to 70°C |
| Storage temperature range | –65°C to 150°C |

‡ Stresses beyond those listed under “absolute maximum ratings” may cause permanent damage to the device. These are stress ratings only, and functional operation of the device at these or any other conditions beyond those indicated under “recommended operating conditions” is not implied. Exposure to absolute-maximum-rated conditions for extended periods may affect device reliability.

recommended operating conditions§

| | SN54AS1034A | | | SN74AS1034A | | | UNIT |
|---|-------------|-----|-----|-------------|-----|-----|------|
| | MIN | NOM | MAX | MIN | NOM | MAX | |
| V _{CC} Supply voltage | 4.5 | 5 | 5.5 | 4.5 | 5 | 5.5 | V |
| V _{IH} High-level input voltage | 2 | | | 2 | | | V |
| V _{IL} Low-level input voltage | | | 0.8 | | | 0.8 | V |
| I _{OH} High-level output current | | | –40 | | | –48 | mA |
| I _{OL} Low-level output current | | | 40 | | | 48 | mA |
| T _A Operating free-air temperature | –55 | | 125 | 0 | | 70 | °C |

§ These high sink- or source-current devices are not recommended for use above 40 MHz.



SN54ALS1034, SN54AS1034A, SN74ALS1034, SN74AS1034A HEX DRIVERS

SDAS053B – APRIL 1982 – REVISED JANUARY 1995

electrical characteristics over recommended operating free-air temperature range (unless otherwise noted)

| PARAMETER | TEST CONDITIONS | | SN54AS1034A | | | SN74AS1034A | | | UNIT |
|-----------------|-------------------------------|-------------------|--------------|------|------|--------------|------|-----|---------|
| | | | MIN | TYP† | MAX | MIN | TYP† | MAX | |
| V_{IK} | $V_{CC} = 4.5 V$, | $I_I = -18 mA$ | -1.2 | | | -1.2 | | | V |
| V_{OH} | $V_{CC} = 4.5 V$ to $5.5 V$, | $I_{OH} = -2 mA$ | $V_{CC} - 2$ | | | $V_{CC} - 2$ | | | V |
| | $V_{CC} = 4.5 V$ | $I_{OH} = -3 mA$ | 2.4 | 3.2 | 2.4 | 3.2 | | | |
| | | $I_{OH} = -40 mA$ | 2 | | | | | | |
| V_{OL} | $V_{CC} = 4.5 V$ | $I_{OL} = 40 mA$ | 0.25 0.5 | | | | | V | |
| | | $I_{OL} = 48 mA$ | | | 0.35 | 0.5 | | | |
| I_I | $V_{CC} = 5.5 V$, | $V_I = 7 V$ | 0.1 | | | 0.1 | | | mA |
| I_{IH} | $V_{CC} = 5.5 V$, | $V_I = 2.7 V$ | 20 | | | 20 | | | μA |
| I_{IL} | $V_{CC} = 5.5 V$, | $V_I = 0.4 V$ | -0.5 | | | -0.5 | | | mA |
| $I_{O\ddagger}$ | $V_{CC} = 5.5 V$, | $V_O = 2.25 V$ | -50 | -200 | -50 | -200 | | mA | |
| I_{CCH} | $V_{CC} = 5.5 V$, | $V_I = 4.5 V$ | 9 | 15 | 9 | 15 | | mA | |
| I_{CCL} | $V_{CC} = 5.5 V$, | $V_I = 0$ | 21 | 35 | 21 | 35 | | mA | |

† All typical values are at $V_{CC} = 5 V$, $T_A = 25^\circ C$.

‡ The output conditions have been chosen to produce a current that closely approximates one half of the true short-circuit output current, I_{OS} .

switching characteristics (see Figure 1)

| PARAMETER | FROM (INPUT) | TO (OUTPUT) | $V_{CC} = 4.5 V$ to $5.5 V$, $C_L = 50 pF$, $R_L = 500 \Omega$, $T_A = MIN$ to MAX § | | | | UNIT |
|-----------|-----------------|----------------|--|-----|-------------|-----|------|
| | | | SN54AS1034A | | SN74AS1034A | | |
| | | | MIN | MAX | MIN | MAX | |
| t_{PLH} | A | Y | 1 | 6.5 | 1 | 6 | ns |
| t_{PHL} | | | 1 | 6.5 | 1 | 6 | |

§ For conditions shown as MIN or MAX, use the appropriate value specified under recommended operating conditions.



PARAMETER MEASUREMENT INFORMATION
SERIES 54ALS/74ALS AND 54AS/74AS DEVICES

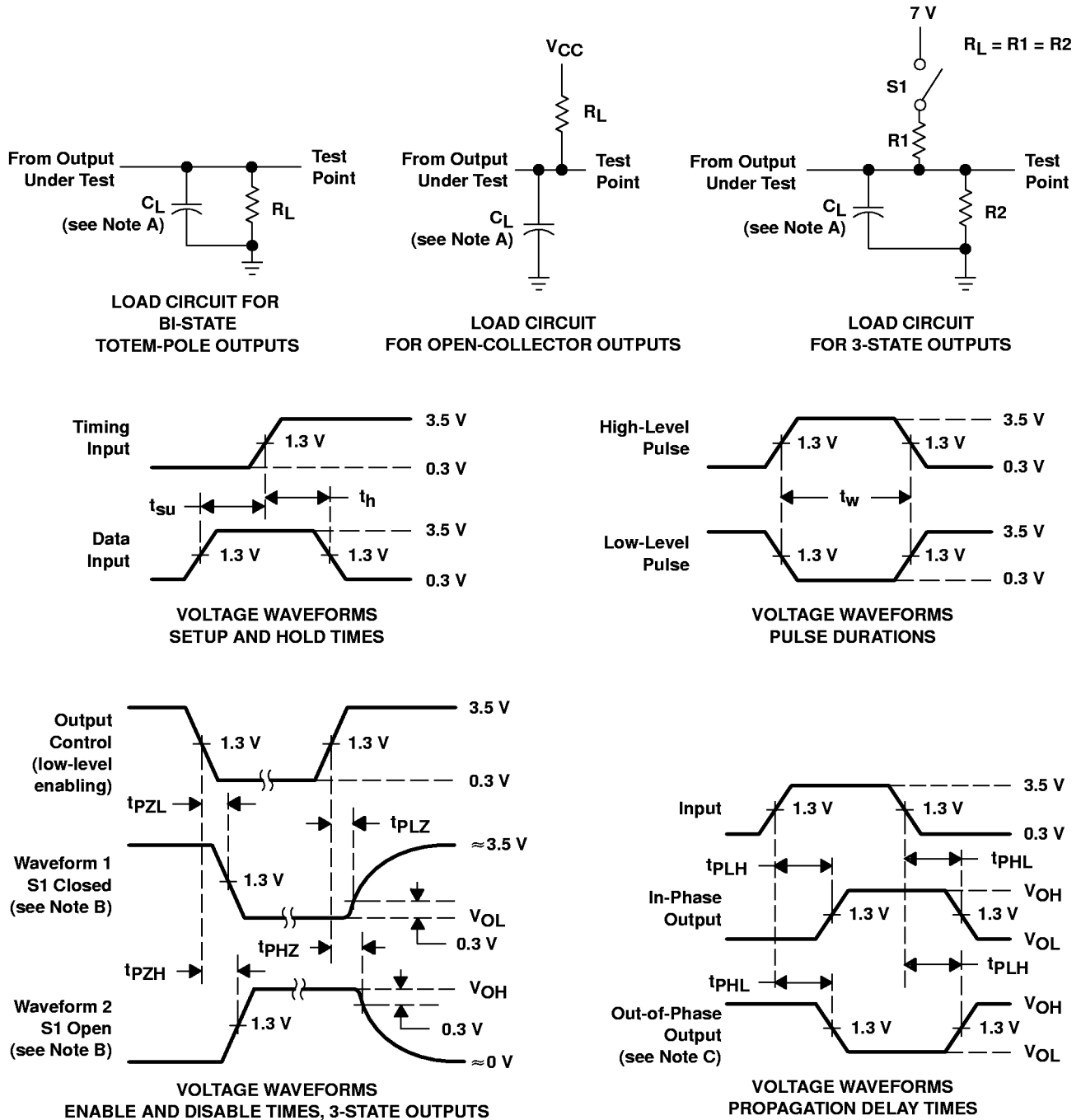

- NOTES: A. C_L includes probe and jig capacitance.
 B. Waveform 1 is for an output with internal conditions such that the output is low except when disabled by the output control. Waveform 2 is for an output with internal conditions such that the output is high except when disabled by the output control.
 C. When measuring propagation delay items of 3-state outputs, switch S1 is open.
 D. All input pulses have the following characteristics: $PRR \leq 1$ MHz, $t_r = t_f = 2$ ns, duty cycle = 50%.
 E. The outputs are measured one at a time with one transition per measurement.

Figure 1. Load Circuits and Voltage Waveforms

IMPORTANT NOTICE

Texas Instruments (TI) reserves the right to make changes to its products or to discontinue any semiconductor product or service without notice, and advises its customers to obtain the latest version of relevant information to verify, before placing orders, that the information being relied on is current.

TI warrants performance of its semiconductor products and related software to the specifications applicable at the time of sale in accordance with TI's standard warranty. Testing and other quality control techniques are utilized to the extent TI deems necessary to support this warranty. Specific testing of all parameters of each device is not necessarily performed, except those mandated by government requirements.

Certain applications using semiconductor products may involve potential risks of death, personal injury, or severe property or environmental damage ("Critical Applications").

TI SEMICONDUCTOR PRODUCTS ARE NOT DESIGNED, INTENDED, AUTHORIZED, OR WARRANTED TO BE SUITABLE FOR USE IN LIFE-SUPPORT APPLICATIONS, DEVICES OR SYSTEMS OR OTHER CRITICAL APPLICATIONS.

Inclusion of TI products in such applications is understood to be fully at the risk of the customer. Use of TI products in such applications requires the written approval of an appropriate TI officer. Questions concerning potential risk applications should be directed to TI through a local SC sales office.

In order to minimize risks associated with the customer's applications, adequate design and operating safeguards should be provided by the customer to minimize inherent or procedural hazards.

TI assumes no liability for applications assistance, customer product design, software performance, or infringement of patents or services described herein. Nor does TI warrant or represent that any license, either express or implied, is granted under any patent right, copyright, mask work right, or other intellectual property right of TI covering or relating to any combination, machine, or process in which such semiconductor products or services might be or are used.