



200Mbps Fiber-Optic VCSEL/Laser Driver

GENERAL DESCRIPTION

The CS6703 is a high-speed fiber optic VCSEL driver ideally suited for applications up to 400Mbps.

The CS6703 is programmable and has fully differential PECL data inputs and CMOS control inputs.

The bias and modulation current of the CS6703 can be set independently via two external resistors; the rise/fall times can also be adjusted using external resistors.

Normally the CS6703 is direct coupled to PECL inputs, however if AC coupling is desired, a $2/3 V_{DD}$ bias point is recommended for operation. Please refer to the application schematic for more details.

FEATURES

- Rise/fall time < 700ps, suitable for applications up to 400Mbps.
- Independently programmable laser bias and modulation current: bias current to 60mA and modulation current to 40mA.
- Differential PECL inputs.
- Programmable rise/fall times.
- Supports both 3.3 and 5 Volt operation.
- Available as die or TSSOP-16 package.

APPLICATIONS

- FDDI
- SDH STM-1
- SONET OC-3
- Fast Ethernet
- Fiber Channel 100
- 155 Mbps ATM
- 155 Mbps SDH/SONET
- VCSEL Driver Transmitters

BLOCK DIAGRAM

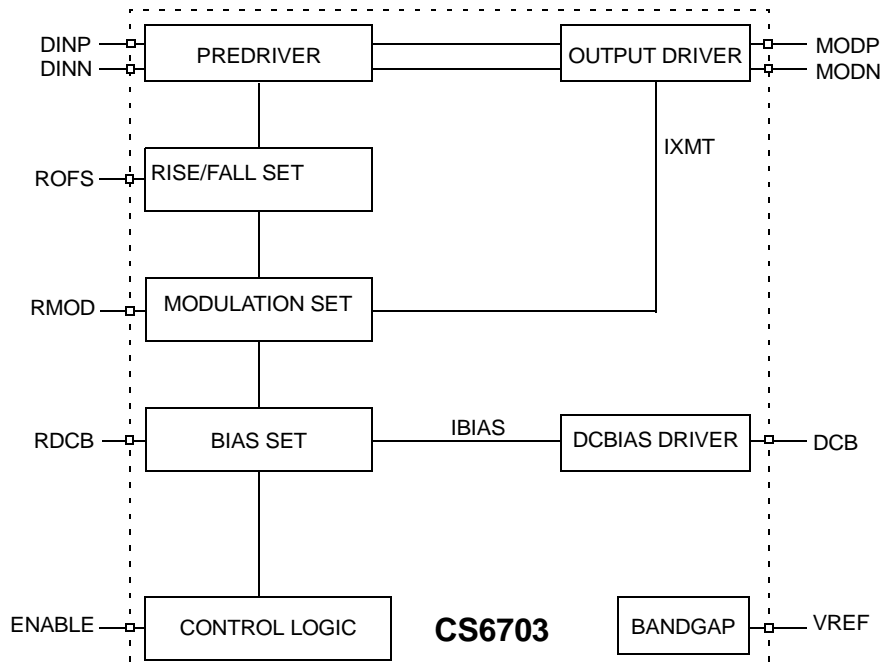



DIE CONNECTION DIAGRAM

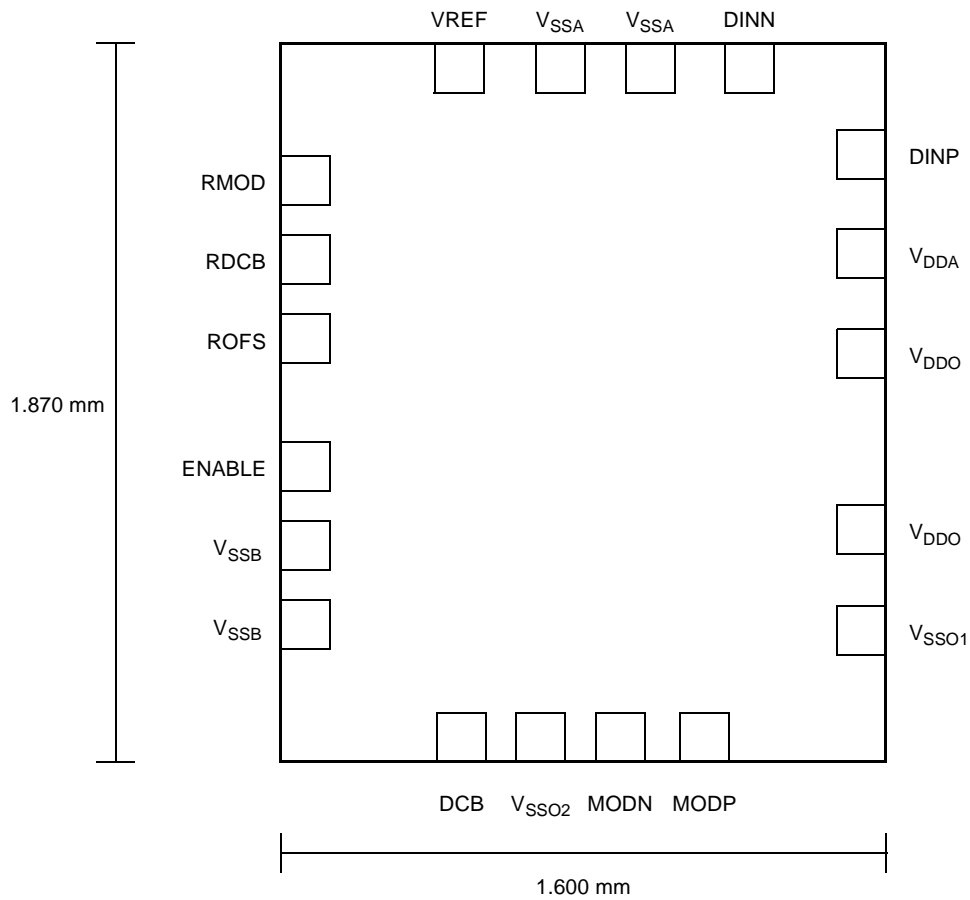

Figure-1

PIN CONNECTION DIAGRAM

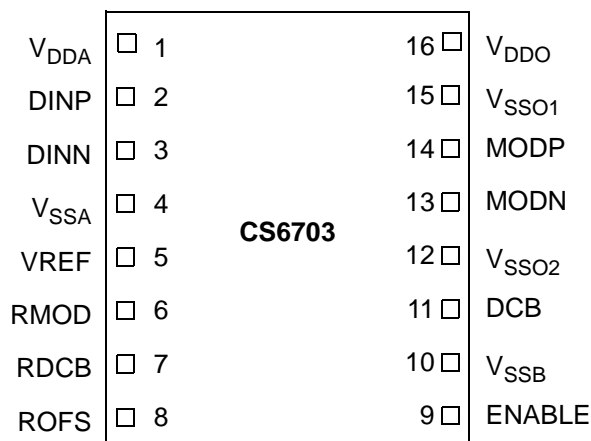

Figure-2 TSSOP-16



PIN DESCRIPTION

Name	Pin	Description
V _{DDA}	1	Input section V _{CC} pin. Connect to most positive supply voltage.
DINP	2	Differential data input pin. Complementary to pin DINN.
DINN	3	Inverse Differential data input pin. Complementary to pin DINP.
V _{SSA}	4	Input section ground pin. Connect to most negative supply voltage.
VREF	5	Reference voltage output pin (approximately 1.8V). Connect a capacitor between this pin and ground.
RMOD	6	Laser modulation current input set pin. Connect a resistor between this pin and ground.
RDCB	7	Laser bias current input set pin. Connect a resistor between this pin and ground.
ROFS	8	Rise/fall time set point input pin. Connect a resistor which is not less than 10k Ω between this pin and ground, or leave as an open circuit.
ENABLE	9	Enable input pin (TTL active high).
V _{SSB}	10	Output section ground pin. Connect to most negative supply voltage.
DCB	11	Laser DC bias current pin.
V _{SSO2}	12	Output section ground pin. Connect to most negative supply voltage.
MODN	13	Inverse driver output stage pin. See application schematic.
MODP	14	Driver output stage pin. See application schematic.
V _{SSO1}	15	Output section ground pin. Connect to most negative supply voltage.
V _{DDO}	16	Output section power pin. Connect to most positive supply voltage.



FUNTIONAL DESCRIPTION

CS6703 consists of a laser bias generator, a modulation current driver, and a rise/fall time adjustment circuit.

Laser bias driver

The laser bias current is adjusted by a resistor $R_{dcb_{set}}$ which is connected between pin RDCB and ground.

$$I_{bias} = 210/R_{dcb_{set}} \text{ for } 3.3V.$$

$$I_{bias} = 220/R_{dcb_{set}} \text{ for } 5V.$$

Modulation Current driver

The modulation current is adjusted by a resistor $R_{mod_{set}}$ which is connected between pin RMOD and ground.

$$I_{mod} = 436/R_{mod_{set}} \text{ for } 3.3V.$$

$$I_{mod} = 477/R_{mod_{set}} \text{ for } 5V.$$

Rise/fall time adjustment

The rise/fall time of the CS6703 can be adjusted by a resistor R_{offset} which is connected between pin ROFS and ground.

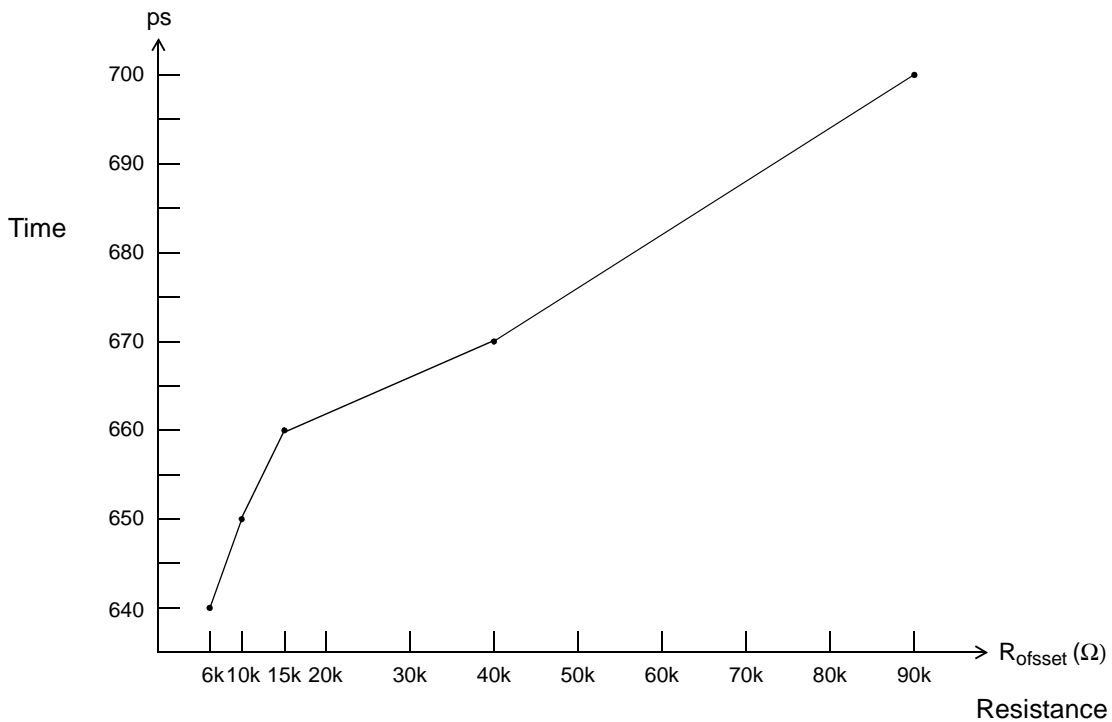

Figure-3 R_{offset} V.S. Rise/Fall time



ABSOLUTE MAXIMUM RATINGS

Symbol	Parameter	Rating	Unit
V_{CC}	Power supply (V_{CC} - Gnd)	6	V
T_a	Operating ambient	-40 to +85	°C
T_{stg}	Storage temperature	-65 to +150	°C

RECOMMENDED OPERATING CONDITIONS

Symbol	Parameter	Rating	Unit
V_{CC}	Power supply (V_{CC} - Gnd)	3 to 5.5	V
T_a	Operating ambient temperature	-40 to +85	°C

ELECTRICAL CHARACTERISTICS

Symbol	Parameter	Min	Typ	Max	Unit
I_{bias}	Range of programmable laser bias current	-	-	60	mA
I_{mod}	Range of programmable modulation current	-	-	45	mA
V_{ih}	PECL input high	-	$V_{CC} - 0.95$	-	V
V_{il}	PECL input low	-	$V_{CC} - 1.75$	-	V
I_{CC}	Supply current	-	$I_{mod} + I_{bias} + 15$	-	mA
T_r/T_f	Rise/fall time	-	700	-	ps



PACKAGE OUTLINE (16-pin TSSOP)

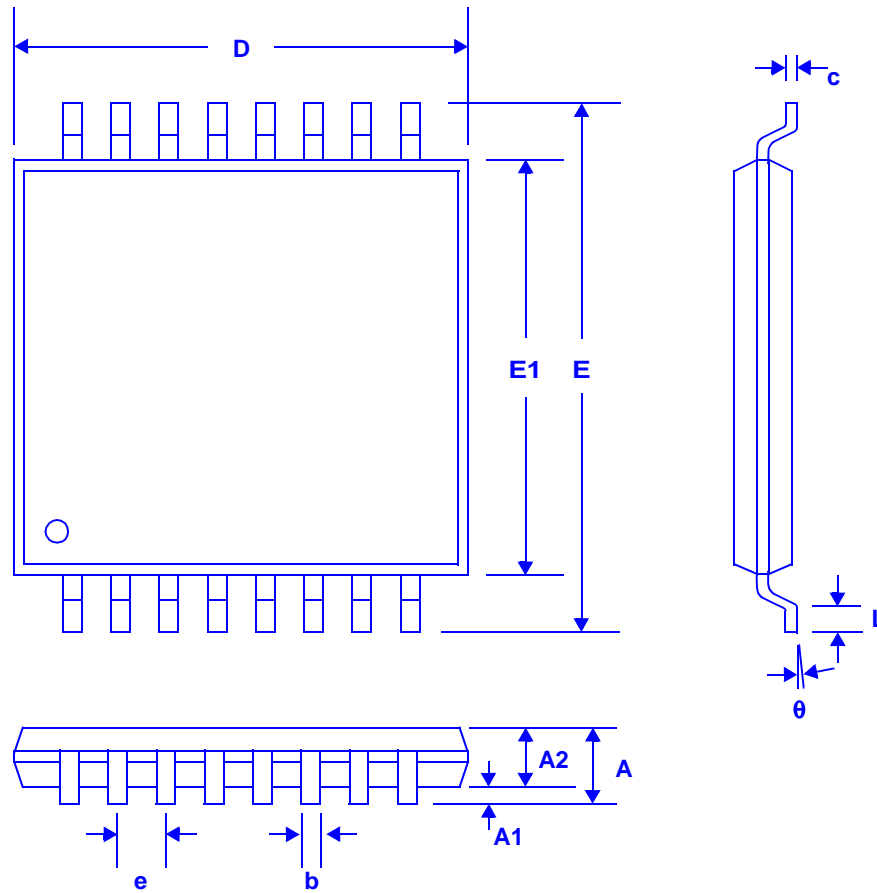

Symbol	Dimensions in Millimeters			Dimensions in Inches		
	MIN	NOM	MAX	MIN	NOM	MAX
A	-	-	1.15	-	-	0.045
A1	0.06	-	0.10	0.000	-	0.004
A2	0.80	1.00	1.05	0.031	0.039	0.041
b	0.19	-	0.30	0.007	-	0.012
c	0.09	-	0.20	0.004	-	0.008
D	4.90	5.00	5.10	0.193	0.197	0.201
E	-	6.40	-	-	0.252	-
E1	4.30	4.40	4.50	0.169	0.173	0.177
e	-	0.65	-	-	0.026	-
L	0.45	0.60	0.75	0.018	0.024	0.030
theta	0°	-	8°	0°	-	8°



APPLICATION CIRCUIT SCHEMATIC

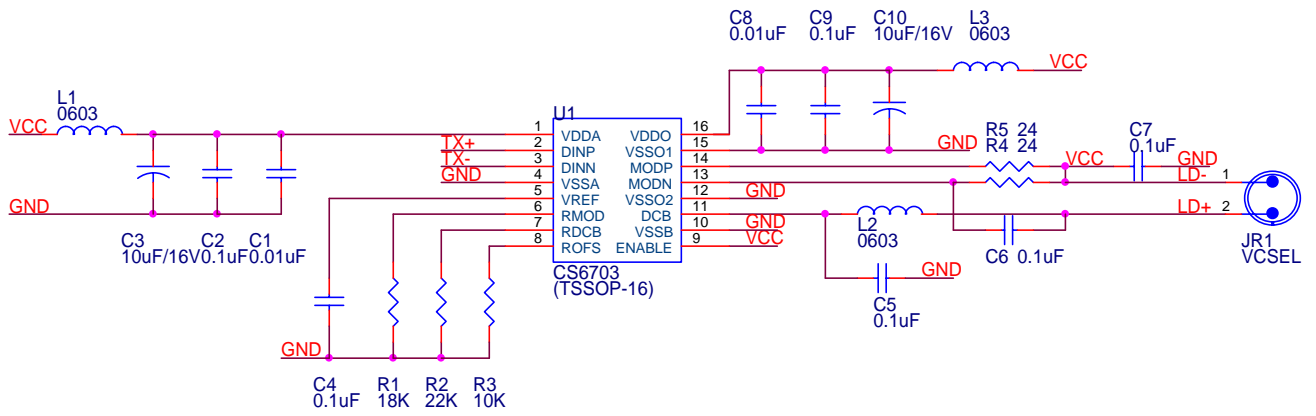

Figure-4 Using TSSOP-16 package