

SN54LS240, SN54LS241, SN54LS244, SN54S240, SN54S241, SN54S244, SN74LS240, SN74LS241, SN74LS244, SN74S240, SN74S241, SN74S244

OCTAL BUFFERS AND LINE DRIVERS WITH 3-STATE OUTPUTS

APRIL 1985—REVISED MARCH 1988

- 3-State Outputs Drive Bus Lines or Buffer Memory Address Registers
- PNP Inputs Reduce D-C Loading
- Hysteresis at Inputs Improves Noise Margins

SN54LS', SN54S' . . . J OR W PACKAGE
SN74LS', SN74S' . . . DW OR N PACKAGE
(TOP VIEW)

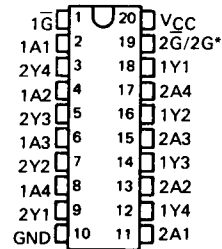

description

These octal buffers and line drivers are designed specifically to improve both the performance and density of three-state memory address drivers, clock drivers, and bus-oriented receivers and transmitters. The designer has a choice of selected combinations of inverting and noninverting outputs, symmetrical \bar{G} (active-low output control) inputs, and complementary \bar{G} and \bar{G} inputs. These devices feature high fan-out, improved fan-in, and 400-mV noise-margin. The SN74LS' and SN74S' can be used to drive terminated lines down to 133 ohms.

The SN54' family is characterized for operation over the full military temperature range of -55°C to 125°C . The SN74' family is characterized for operation from 0°C to 70°C .

SN54LS', SN54S' . . . FK PACKAGE
(TOP VIEW)

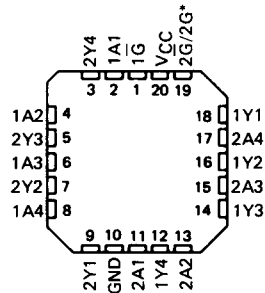

*2G for 'LS241 and 'S241 or 2G for all other drivers.

2

TTL Devices

schematics of inputs and outputs

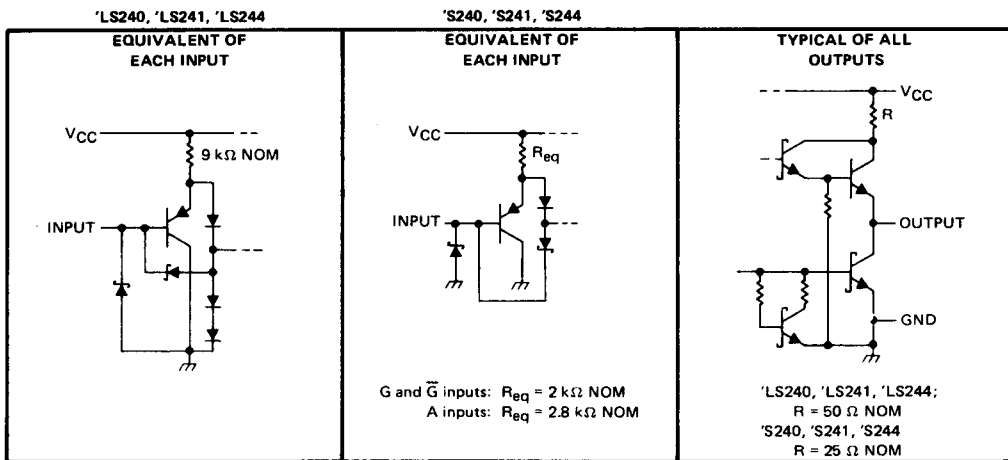

PRODUCTION DATA documents contain information current as of publication date. Products conform to specifications per the terms of Texas Instruments standard warranty. Production processing does not necessarily include testing of all parameters.

TEXAS
INSTRUMENTS

POST OFFICE BOX 655012 • DALLAS, TEXAS 75265

2-691

SN54LS240, SN54LS241, SN54LS244, SN54S240, SN54S241, SN54S244, SN74LS240, SN74LS241, SN74LS244, SN74S240, SN74S241, SN74S244 OCTAL BUFFERS AND LINE DRIVERS WITH 3-STATE OUTPUTS

logic symbols†

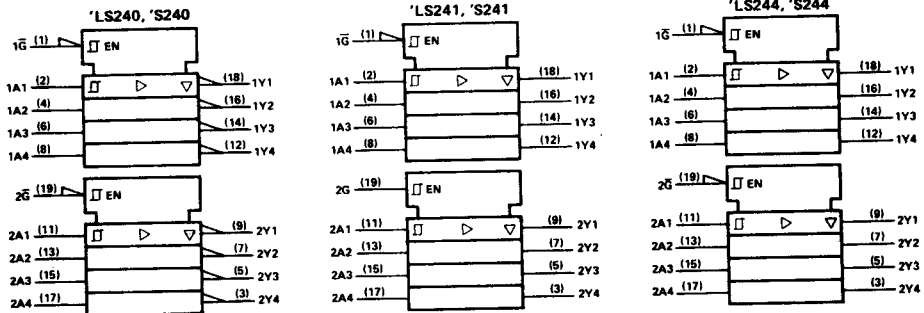

†These symbols are in accordance with ANSI/IEEE Std. 91-1984 and IEC Publication 617-12.

logic diagrams (positive logic)

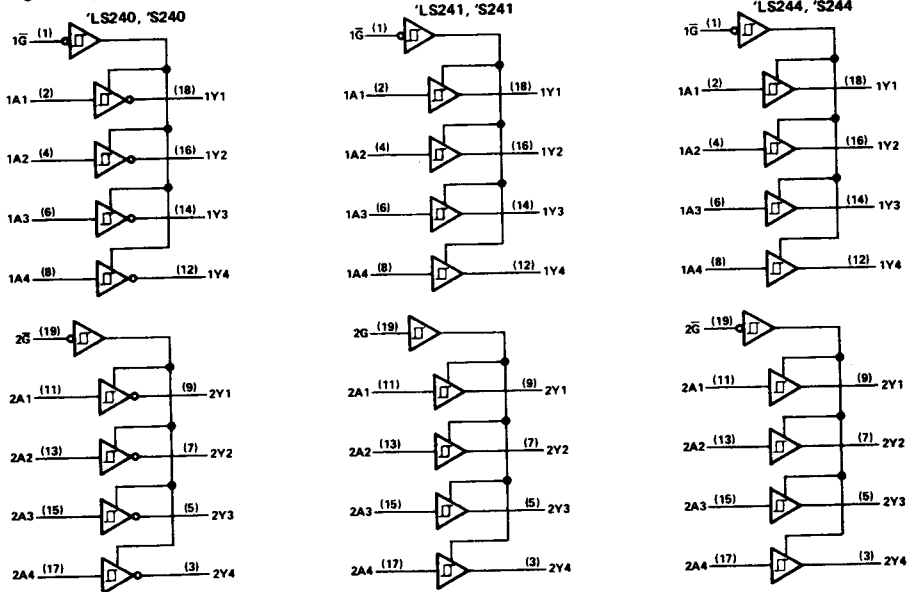

Pin numbers shown are for DW, J, N, and W packages.

absolute maximum ratings over operating free-air temperature range (unless otherwise noted)

Supply voltage, V_{CC} (see Note 1)	7 V
Input voltage: 'LS Circuits	7 V
'S Circuits	5.5 V
Off-state output voltage	5.5 V
Operating free-air temperature range: SN54LS', SN54S' Circuits	-55° C to 125° C
SN74LS', SN74S' Circuits	0° C to 70° C
Storage temperature range	-65° C to 150° C

NOTE 1: Voltage values are with respect to network ground terminal.

2

TTL Devices

SN54LS240, SN54LS241, SN54LS244, SN74LS240, SN74LS241, SN74LS244

OCTAL BUFFERS AND LINE DRIVERS WITH 3-STATE OUTPUTS

recommended operating conditions

PARAMETER	SN54LS'			SN74LS'			UNIT
	MIN	NOM	MAX	MIN	NOM	MAX	
V _{CC} Supply voltage (see Note 1)	4.5	5	5.5	4.75	5	5.25	V
V _{IH} High-level input voltage	2			2			V
V _{IL} Low-level input voltage			0.7			0.8	V
I _{OH} High-level output current			-12			-15	mA
I _{OL} Low-level output current			12			24	mA
T _A Operating free-air temperature	-55		125	0		70	°C

NOTE 1: Voltage values are with respect to network ground terminal.

electrical characteristics over recommended operating free-air temperature range (unless otherwise noted)

PARAMETER	TEST CONDITIONS†			SN54LS'			SN74LS'			UNIT
				MIN	TYP‡	MAX	MIN	TYP‡	MAX	
V _{IK}	V _{CC} = MIN, I _I = -18 mA			-1.5			-1.5			V
Hysteresis (V _{T+} - V _{T-})	V _{CC} = MIN			0.2	0.4		0.2	0.4		V
V _{OH}	V _{CC} = MIN, V _{IH} = 2 V, V _{IL} = MAX, I _{OH} = -3 mA			2.4	3.4		2.4	3.4		V
	V _{CC} = MIN, V _{IH} = 2 V, V _{IL} = 0.5 V, I _{OH} = MAX			2			2			
V _{OL}	V _{CC} = MIN, V _{IH} = 2 V, V _{IL} = MAX			0.4			0.4			V
	V _{CC} = MAX, V _{IH} = 2 V, V _O = 2.7 V			20			20			
I _{OZH}	V _{CC} = MAX, V _{IH} = 2 V, V _{IL} = MAX			-20			-20			μA
I _{OZL}	V _{CC} = MAX, V _I = 7 V			0.1			0.1			mA
I _{IH}	V _{CC} = MAX, V _I = 2.7 V			20			20			μA
I _{IL}	V _{CC} = MAX, V _{IL} = 0.4 V			-0.2			-0.2			mA
I _{OS} §	V _{CC} = MAX			-40	-225		-40	-225		mA
I _{CC}	Outputs high	V _{CC} = MAX, Output open			All	17	27	17	27	mA
	Outputs low				'LS240	26	44	26	44	
	All outputs disabled				'LS241, 'LS244	27	46	27	46	
					'LS240	29	50	29	50	
					'LS241, 'LS244	32	54	32	54	

† For conditions shown as MIN or MAX, use the appropriate value specified under recommended operating conditions.

‡ All typical values are at V_{CC} = 5 V, T_A = 25°C.

§ Not more than one output should be shorted at a time, and duration of the short-circuit should not exceed one second.

switching characteristics, V_{CC} = 5 V, T_A = 25°C

PARAMETER	TEST CONDITIONS		'LS240			'LS241, 'LS244			UNIT
			MIN	TYP	MAX	MIN	TYP	MAX	
t _{PLH}	R _L = 667 Ω, See Note 2	C _L = 45 pF,	9	14		12	18		ns
t _{PHL}			12	18		12	18		ns
t _{PZL}			20	30		20	30		ns
t _{PZH}			15	23		15	23		ns
t _{PLZ}	R _L = 667 Ω, See Note 2	C _L = 5 pF,	10	20		10	20		ns
t _{PHZ}			15	25		15	25		ns

NOTE 2: Load circuits and voltage waveforms are shown in Section 1.

2

TTL Devices

SN54S240, SN54S241, SN54S244, SN74S240, SN74S241, SN74S244, OCTAL BUFFERS AND LINE DRIVERS WITH 3-STATE OUTPUTS

recommended operating conditions

PARAMETER	SN54S'			SN74S'			UNIT
	MIN	NOM	MAX	MIN	NOM	MAX	
V _{CC} Supply voltage, (see Note 1)	4.5	5	5.5	4.75	5	5.25	V
V _{IH} High-level input voltage	2			2			V
V _{IL} Low-level input voltage				0.8			V
I _{OH} High-level output current				-12			mA
I _{OL} Low-level output current				48			mA
External resistance between any input and V _{CC} or ground				40			kΩ
T _A Operating free-air temperature (see Note 3)	-55			125			°C

NOTES: 1. Voltage values are with respect to network ground terminal.
 2. An SN54S241J operating at free-air temperature above 116°C requires a heat sink that provides a thermal resistance from case to free-air R_{θCA}, of not more than 40°C/W.

electrical characteristics over recommended operating free-air temperature range (unless otherwise noted)

PARAMETER	TEST CONDITIONS†		SN54S'			SN74S'			UNIT
			MIN	TYP‡	MAX	MIN	TYP‡	MAX	
V _{IK}	V _{CC} = MIN, I _I = -18 mA		-1.2			-1.2			V
Hysteresis (V _{T+} - V _{T-})	V _{CC} = MIN		0.2	0.4		0.2	0.4		V
V _{OH}	V _{CC} = MIN, V _{IH} = 2 V, V _{IL} = 0.8 V, I _{OH} = -1 mA					2.7			V
	V _{CC} = MIN, V _{IH} = 2 V, V _{IL} = 0.8 V, I _{OH} = -3 mA		2.4	3.4		2.4	3.4		
	V _{CC} = MIN, V _{IH} = 2 V, V _{IL} = 0.5 V, I _{OH} = MAX		2			2			
V _{OL}	V _{CC} = MIN, V _{IH} = 2 V, V _{IL} = 0.8 V, I _{OL} = MAX		0.55			0.55			V
I _{OZH}	V _{CC} = MAX, V _{IH} = 2 V, V _O = 2.4 V		50			50			μA
I _{OZL}	V _{CC} = MAX, V _{IH} = 2 V, V _{IL} = 0.8 V, V _O = 0.5 V		-50			-50			μA
I _I	V _{CC} = MAX, V _I = 5.5 V		1			1			mA
I _{IH}	V _{CC} = MAX, V _I = 2.7 V		50			50			μA
I _{IL}	Any A		-400			-400			μA
	Any G		-2			-2			mA
I _{OS} §	V _{CC} = MAX		-50			-225			mA
I _{CC}	Outputs high	V _{CC} = MAX, Outputs open	'S240	80	123	80	135	mA	
			'S241, 'S244	95	147	95	160		
	Outputs low		'S240	100	145	100	150		
			'S241, 'S244	120	170	120	180		
	Outputs disabled		'S240	100	145	100	150		
			'S241, 'S244	120	170	120	180		

† For conditions shown as MIN or MAX, use the appropriate value specified under recommended operating conditions.

‡ All typical values are at V_{CC} = 5 V, T_A = 25°C.

§ Not more than one output should be shorted at a time, and duration of the short-circuit should not exceed one second.

2

TTL Devices

**SN54S240, SN54S241, SN54S244, SN74S240, SN74S241, SN74S244,
OCTAL BUFFERS AND LINE DRIVERS WITH 3-STATE OUTPUTS**

switching characteristics, $V_{CC} = 5\text{ V}$, $T_A = 25^\circ\text{C}$

PARAMETER	TEST CONDITIONS	'S240			'S241, 'S244			UNIT
		MIN	TYP	MAX	MIN	TYP	MAX	
t _{PLH}	R _L = 90 Ω, See Note 4 C _L = 50 pF,	4.5		7	6		9	ns
t _{PHL}		4.5		7	6		9	ns
t _{PZL}		10		15	10		15	ns
t _{PZH}		6.5		10	8		12	ns
t _{PLZ}	R _L = 90 Ω, See Note 4 C _L = 5 pF,	10		15	10		15	ns
t _{PHZ}		6		9	6		9	ns

NOTE 4: Load circuits and voltage waveforms are shown in Section 1.

**SN54LS240, SN54LS241, SN54LS244, SN54S240, SN54S241, SN54S244,
SN74LS240, SN74LS241, SN74LS244, SN74S240, SN74S241, SN74S244
OCTAL BUFFERS AND LINE DRIVERS WITH 3-STATE OUTPUTS**

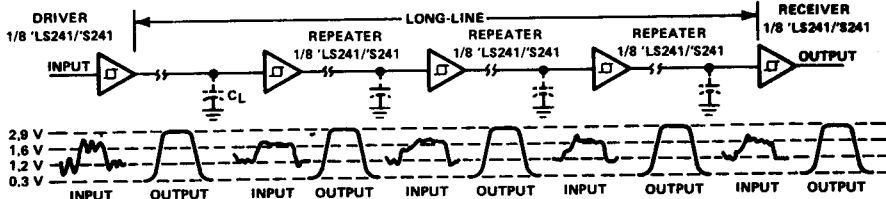

'LS241, 'S241 USED AS REPEATER/LEVEL RESTORER

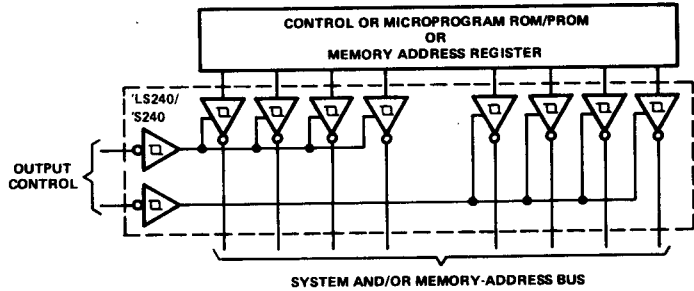

'LS240/'S240 USED AS SYSTEM AND/OR MEMORY BUS DRIVER—4-BIT ORGANIZATION CAN BE APPLIED TO HANDLE BINARY OR BCD

2

TTL Devices

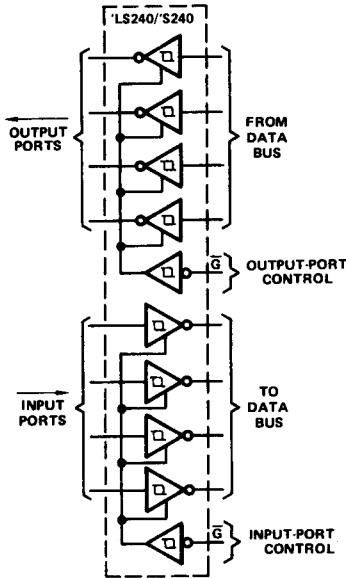

INDEPENDENT 4-BIT BUS DRIVERS/RECEIVERS IN A SINGLE PACKAGE

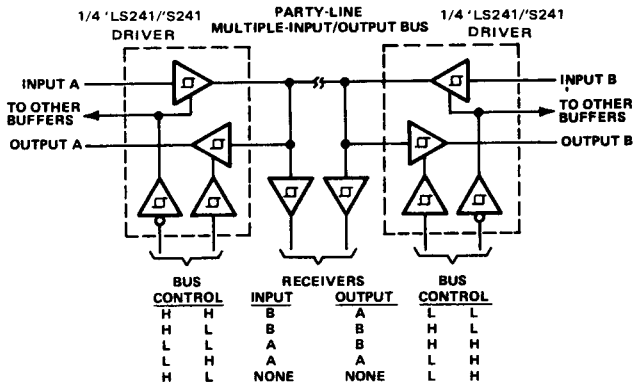

PARTY-LINE BUS SYSTEM WITH MULTIPLE INPUTS, OUTPUTS, AND RECEIVERS