



# 3.3V CMOS HEX INVERTER WITH OPEN-DRAIN OUT- PUTS, 5 VOLT TOLERANT I/O

**IDT74LVC05A**  
**ADVANCE**  
**INFORMATION**

## FEATURES:

- 0.5 MICRON CMOS Technology
- ESD > 2000V per MIL-STD-883, Method 3015;  
> 200V using machine model (C = 200pF, R = 0)
- 1.27mm pitch SOIC, 0.65mm pitch SSOP and  
0.65mm pitch TSSOP packages
- Extended commercial range of - 40°C to +85°C
- Vcc = 3.3V ±0.3V, Normal Range
- Vcc = 2.3V to 3.6V, Extended Range
- CMOS power levels (0.4µW typ. static)
- Rail-to-Rail output swing for increased noise margin
- All inputs, outputs and I/O are 5 Volt tolerant
- Supports hot insertion

### Drive Features for LVC05A:

- High Output Drivers: +24mA
- Reduced system switching noise

## DESCRIPTION:

This hex inverter is built using advanced dual metal CMOS technology. The outputs of the LVC05A device are open-drain and can be connected to other open-drain outputs to implement active-low wired-OR or active-high wired-AND functions. The maximum sink current is 24mA.

The LVC05A has been designed with a +24mA output driver. This driver is capable of driving a moderate to heavy load while maintaining speed performance.

Inputs can be driven from either 3.3V or 5V devices. This feature allows the use of this device as a translator in a mixed 3.3V/5V system environment.

## APPLICATIONS:

- 3.3V High Speed Systems
- 3.3V and lower voltage computing systems

## Functional Block Diagram

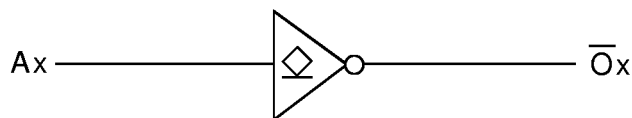

## PIN CONFIGURATION

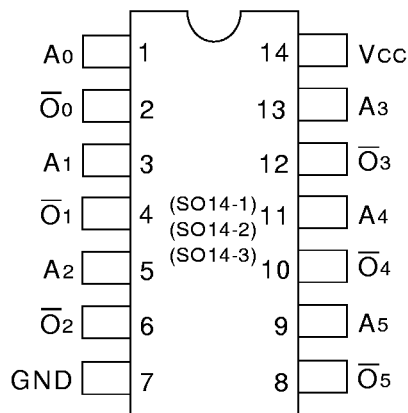

SOIC/ SSOP/ TSSOP  
TOP VIEW

## FUNCTION TABLE (each inverter) <sup>(1)</sup>

Inputs	Outputs (with pull-up)
Ax	Ox-bar
L	H
H	L

### NOTE:

1. H = HIGH Voltage Level  
L = LOW Voltage Level

## PIN DESCRIPTION

Pin Names	Description
Ax	Data Inputs
Ox-bar	Data Outputs

**ABSOLUTE MAXIMUM RATINGS (1)**

Symbol	Description	Max.	Unit
V <sub>TERM</sub> (2)	Terminal Voltage with Respect to GND	- 0.5 to +6.5	V
V <sub>TERM</sub> (3)	Terminal Voltage with Respect to GND	- 0.5 to +6.5	V
T <sub>STG</sub>	Storage Temperature	- 65 to +150	°C
I <sub>OUT</sub>	DC Output Current	- 50 to +50	mA
I <sub>IK</sub> I <sub>OK</sub>	Continuous Clamp Current, V <sub>I</sub> < 0 or V <sub>O</sub> < 0	- 50	mA
I <sub>CC</sub> I <sub>SS</sub>	Continuous Current through each V <sub>CC</sub> or GND	±100	mA

LVC QUAD Link

**NOTES:**

- Stresses greater than those listed under ABSOLUTE MAXIMUM RATINGS may cause permanent damage to the device. This is a stress rating only and functional operation of the device at these or any other conditions above those indicated in the operational sections of this specification is not implied. Exposure to absolute maximum rating conditions for extended periods may affect reliability.
- V<sub>CC</sub> terminals.
- All terminals except V<sub>CC</sub>.

**CAPACITANCE (T<sub>A</sub> = +25°C, f = 1.0MHz)**

Symbol	Parameter(1)	Conditions	Typ.	Max.	Unit
C <sub>IN</sub>	Input Capacitance	V <sub>IN</sub> = 0V	4.5	6	pF
C <sub>OUT</sub>	Output Capacitance	V <sub>OUT</sub> = 0V	5.5	8	pF
C <sub>I/O</sub>	I/O Port Capacitance	V <sub>IN</sub> = 0V	6.5	8	pF

LVC QUAD Link

**NOTE:**

- As applicable to the device type.

**DC ELECTRICAL CHARACTERISTICS OVER OPERATING RANGE**

Following Conditions Apply Unless Otherwise Specified:

Operating Condition: T<sub>A</sub> = - 40°C to +85°C

Symbol	Parameter	Test Conditions		Min.	Typ.(1)	Max.	Unit
V <sub>IH</sub>	Input HIGH Voltage Level	V <sub>CC</sub> = 2.3V to 2.7V		1.7	—	—	V
		V <sub>CC</sub> = 2.7V to 3.6V		2	—	—	
V <sub>IL</sub>	Input LOW Voltage Level	V <sub>CC</sub> = 2.3V to 2.7V		—	—	0.7	V
		V <sub>CC</sub> = 2.7V to 3.6V		—	—	0.8	
I <sub>IH</sub> I <sub>IL</sub>	Input Leakage Current	V <sub>CC</sub> = 3.6V	V <sub>I</sub> = 0 to 5.5V	—	—	±5	µA
I <sub>OZH</sub> I <sub>OZL</sub>	High Impedance Output Current (3-State Output pins)	V <sub>CC</sub> = 3.6V	V <sub>O</sub> = 0 to 5.5V	—	—	±10	µA
I <sub>OFF</sub>	Input/Output Power Off Leakage	V <sub>CC</sub> = 0V, V <sub>IN</sub> or V <sub>O</sub> ≤ 5.5V		—	—	±50	µA
V <sub>IK</sub>	Clamp Diode Voltage	V <sub>CC</sub> = 2.3V, I <sub>IN</sub> = - 18mA		—	- 0.7	- 1.2	V
V <sub>H</sub>	Input Hysteresis	V <sub>CC</sub> = 3.3V		—	100	—	mV
I <sub>CCL</sub> I <sub>CCH</sub> I <sub>CCZ</sub>	Quiescent Power Supply Current	V <sub>CC</sub> = 3.6V	V <sub>IN</sub> = GND or V <sub>CC</sub>	—	—	10	µA
ΔI <sub>CC</sub>	Quiescent Power Supply Current Variation	One input at V <sub>CC</sub> - 0.6V other inputs at V <sub>CC</sub> or GND		—	—	500	µA

LVC QUAD Link

**NOTE:**

- Typical values are at V<sub>CC</sub> = 3.3V, +25°C ambient.

**OUTPUT DRIVE CHARACTERISTICS**

Symbol	Parameter	Test Conditions <sup>(1)</sup>		Min.	Max.	Unit
		V <sub>CC</sub>	I <sub>OL</sub>			
V <sub>OL</sub>	Output LOW Voltage	V <sub>CC</sub> = 2.3V to 3.6V	I <sub>OL</sub> = 0.1mA	—	0.2	V
		V <sub>CC</sub> = 2.3V	I <sub>OL</sub> = 6mA	—	0.4	
			I <sub>OL</sub> = 12mA	—	0.7	
		V <sub>CC</sub> = 2.7V	I <sub>OL</sub> = 12mA	—	0.4	
		V <sub>CC</sub> = 3.0V	I <sub>OL</sub> = 24mA	—	0.55	

**NOTE:**

- V<sub>IH</sub> and V<sub>IL</sub> must be within the min. or max. range shown in the DC ELECTRICAL CHARACTERISTICS OVER OPERATING RANGE table for the appropriate V<sub>CC</sub> range. T<sub>A</sub> = -40°C to +85°C.

**OPERATING CHARACTERISTICS, T<sub>A</sub> = 25°C**

Symbol	Parameter	Test Conditions	V <sub>CC</sub> = 2.5V±0.2V	V <sub>CC</sub> = 3.3V±0.3V	Unit
			Typical	Typical	
CPD	Power dissipation capacitance per buffer/driver	C <sub>L</sub> = 0pF, f = 10MHz			pF

**SWITCHING CHARACTERISTICS (1)**

Symbol	Parameter	V <sub>CC</sub> = 2.5V±0.2V		V <sub>CC</sub> = 2.7V		V <sub>CC</sub> = 3.3V±0.3V		Unit
		Min.	Max.	Min.	Max.	Min.	Max.	
t <sub>PHL</sub>	Propagation Delay x <sub>A</sub> to x <sub>Y</sub>							ns
t <sub>SK(o)</sub>	Output Skew <sup>(2)</sup>							ps

**NOTES:**

- See test circuits and waveforms. T<sub>A</sub> = -40°C to +85°C.
- Skew between any two outputs of the same package and switching in the same direction.

## TEST CIRCUITS AND WAVEFORMS

### TEST CONDITIONS

Symbol	V <sub>CC</sub> (1)= 2.5V ±0.2V	V <sub>CC</sub> (2)= 3.3V ±0.3V & 2.7V	Unit
V <sub>LOAD</sub>	2 x V <sub>CC</sub>	6	V
V <sub>IH</sub>	V <sub>CC</sub>	2.7	V
V <sub>T</sub>	V <sub>CC</sub> / 2	1.5	V
V <sub>LZ</sub>	150	300	mV
V <sub>HZ</sub>	150	300	mV
C <sub>L</sub>	30	50	pF

LVC QUAD Link

### PROPAGATION DELAY

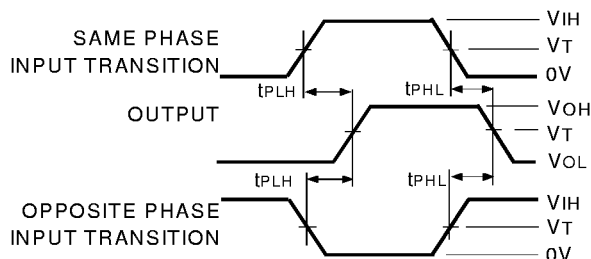

LVC QUAD Link

### TEST CIRCUITS FOR ALL OUTPUTS

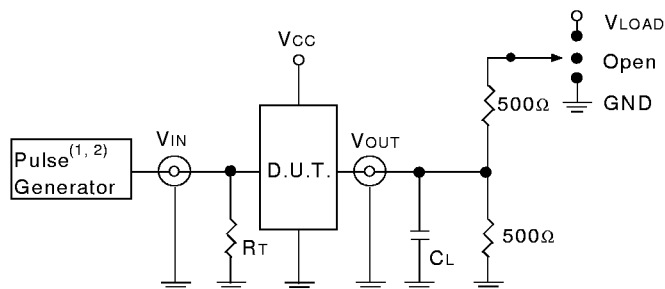

LVC QUAD Link

#### DEFINITIONS:

C<sub>L</sub>= Load capacitance: includes jig and probe capacitance.  
R<sub>T</sub>= Termination resistance: should be equal to Z<sub>OUT</sub> of the Pulse Generator.

#### NOTES:

1. Pulse Generator for All Pulses: Rate ≤ 10MHz; t<sub>F</sub> ≤ 2ns; t<sub>R</sub> ≤ 2ns.
2. Pulse Generator for All Pulses: Rate ≤ 10MHz; t<sub>F</sub> ≤ 2.5ns; t<sub>R</sub> ≤ 2.5ns.

### ENABLE AND DISABLE TIMES

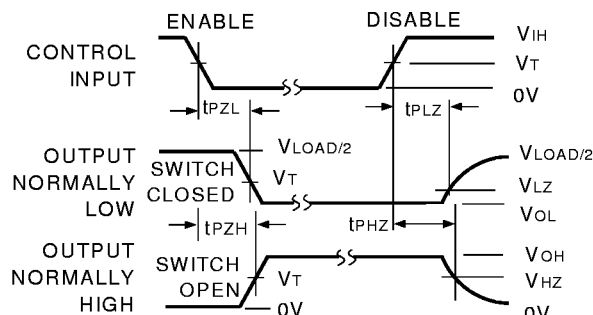

LVC QUAD Link

#### NOTE:

1. Diagram shown for input Control Enable-LOW and input Control Disable-HIGH.

### SWITCH POSITION

Test	Switch
Open Drain Disable Low Enable Low	V <sub>LOAD</sub>
Disable High Enable High	GND
All Other tests	Open

LVC QUAD Link

### OUTPUT SKEW - t<sub>SK</sub>(x)

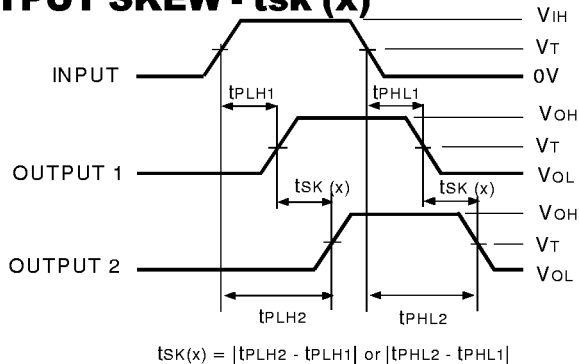

$$t_{SK}(x) = |t_{PLH2} - t_{PLH1}| \text{ or } |t_{PHL2} - t_{PHL1}|$$

LVC QUAD Link

#### NOTES:

1. For t<sub>SK</sub>(a) OUTPUT1 and OUTPUT2 are any two outputs.
2. For t<sub>SK</sub>(b) OUTPUT1 and OUTPUT2 are in the same bank.

### SET-UP, HOLD, AND RELEASE TIMES

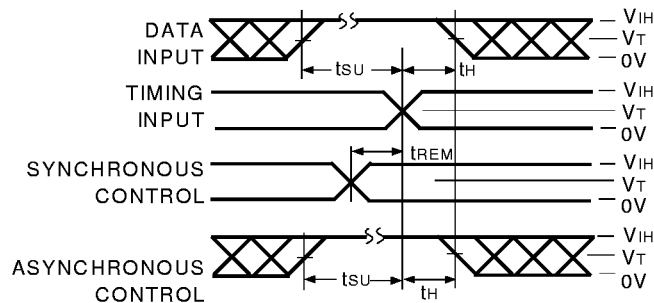

LVC QUAD Link

### PULSE WIDTH

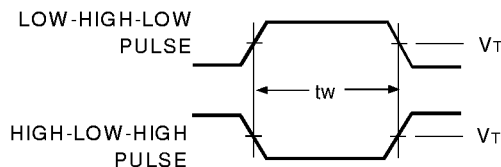

LVC QUAD Link

## ORDERING INFORMATION

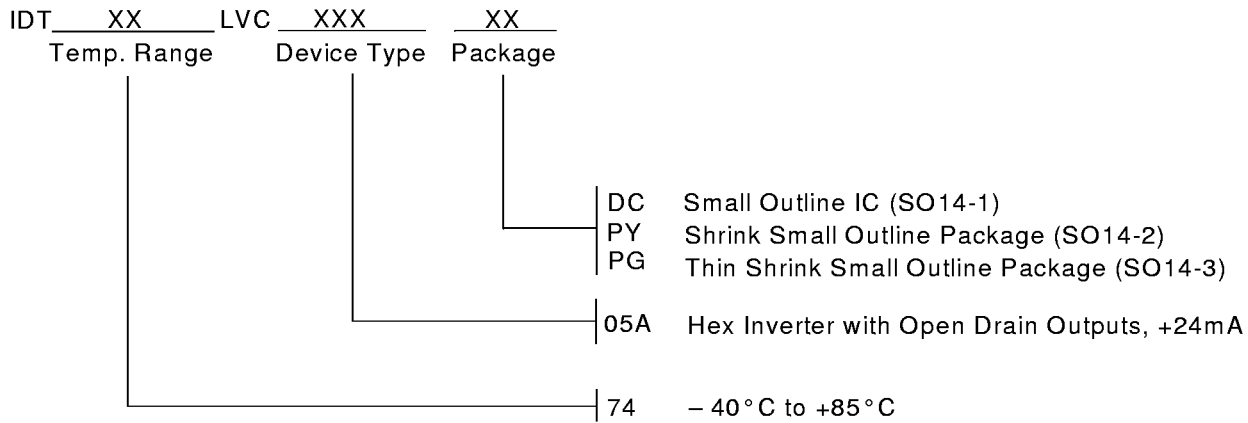

**CORPORATE HEADQUARTERS**  
2975 Stender Way  
Santa Clara, CA 95054

**for SALES:**  
800-345-7015 or 408-727-6116  
fax: 408-492-8674  
[www.idt.com](http://www.idt.com)\*

*\*To search for sales office near you, please click the sales button found on our home page or dial the 800# above and press 2.  
The IDT logo is a registered trademark of Integrated Device Technology, Inc.*