



MOTOROLA

Quad Single-Ended Line Drivers

The MC3481 and MC3485 are quad single-ended line drivers specifically designed to meet the IBM 360/370 I/O specification (GA22-6974-3).

Output levels are guaranteed over the full range of output load and fault conditions. Compliance with the IBM requirements for fault protection, flagging, and power up/power down protection for the bus make this an ideal line driver for parity line operations.

- Separate Enable and Fault Flags – MC3481
- Common Enable and Fault Flag – MC3485
- Power Up/Down Does Not Disturb Bus
- Schottky Circuitry for High-Speed – PNP Inputs
- Internal Bootstraps for Faster Rise Times
- Driver Output Current Foldback Protection
- MC3485 has LS Totem Pole Driver Output

MC3481 MC3485

IBM 360/370 QUAD LINE DRIVERS

SEMICONDUCTOR
TECHNICAL DATA

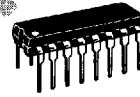

P SUFFIX
PLASTIC PACKAGE
CASE 648

7

PIN CONNECTIONS

MC3481: Dual Enable Individual Fault Flag

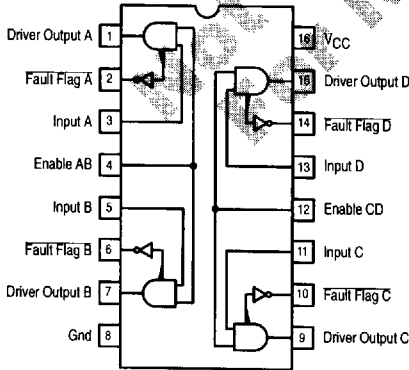

MC3485: Common Enable Common Fault Flag

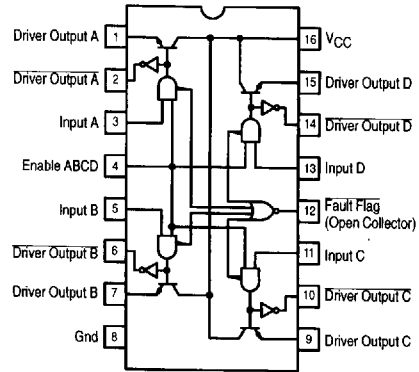

Simplified Application

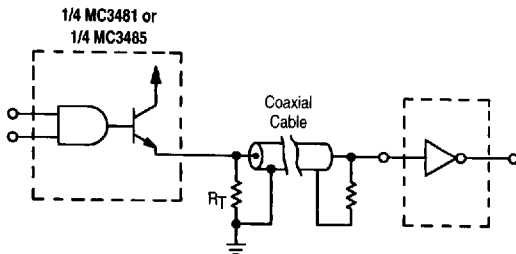

ORDERING INFORMATION

Device	Operating Temperature Range	Package
MC3481P	$T_A = 0 \text{ to } +70^\circ\text{C}$	Plastic DIP
MC3485P		

MC3481 MC3485

MAXIMUM RATINGS (T_A = 25°C, unless otherwise noted)

Rating	Symbol	Value	Unit
Power Supply Voltage	V _{CC}	+ 7.0	V
Input Voltage	V _I	10	V
Driver Output Voltage	V _O	5.5	V
Power Dissipation (Package Limitation) Derate Above T _A = 25°C	P _D 1/R _{θJA}	962 7.7	mW mW/°C
Operating Ambient Temperature Range	T _A	0 to + 70	°C
Junction Temperature	T _J	+ 150	°C
Storage Temperature Range	T _{stg}	65 to + 150	°C

RECOMMENDED OPERATING CONDITIONS

Characteristic	Symbol	Min	Typ	Max	Unit
Power Supply Voltage	V _{CC}	4.5	5.0	5.95	V _{dc}
High Level Output Current	I _{OH}	–	–	59.3	mA
Operating Ambient Temperature Range	T _A	0		+ 70	°C

SWITCHING CHARACTERISTICS (See Note 1. Unless otherwise noted, these specifications apply over recommended temperature range. I/O Driver characteristics are guaranteed for V_{CC} = 5.0 V ± 10 % and Select–Out Driver characteristics are guaranteed for V_{CC} = 5.25 to 5.95 V. Typical values measured at T_A = 25 °C and V_{CC} = 6.0 V. See Tables 1 and 2, Figures 1 and 2 for load conditions.)

Characteristics	Symbol	Min	Typ	Max	Unit
Propagation Delay Time					ns
High–to–Low–Level, Driver Output					
As I/O Driver	t _{PHL(D)}	–	18	–	
As Select–Out Driver	t _{PHL(DS)}	–	19	–	
Low–to–High–Level, Driver Output					
As I/O Driver	t _{PLH(D)}	–	20	–	
As Select–Out Driver	t _{PLH(DS)}	–	21	–	
High–to–Low–Level, Driver Output					
As I/O Driver	t _{PHL(D)}	–	25	–	
As Select–Out Driver	t _{PHL(DS)}	–	26	–	
Low–to–High–Level, Driver Output					
As I/O Driver	t _{PLH(D)}	–	25	–	
As Select–Out Driver	t _{PLH(DS)}	–	26	–	
High–to–Low–Level, Fault Flag – MC3481					
As I/O Driver	t _{PHL(F)}	–	45	–	
As Select–Out Driver	t _{PHL(FS)}	–	47	–	
Low–to–High–Level, Fault Flag – MC3481					
As I/O Driver	t _{PLH(F)}	–	40	–	
As Select–Out Driver	t _{PLH(FS)}	–	42	–	
Ratio of Propagation Delay Times					
As I/O Driver	t _{PLH(D)} t _{PHL(D)}	–	1.0	–	

NOTES: 1. Reference IBM specification GA22–6974–3 for test terminology.

2. The fault protection circuitry of the MC3481 and MC3485 requires relatively clean input voltage waveforms for current operation. Noise pulses which enter the threshold region (0.8 to 2.0 V) may cause the output to enter the fault protect mode. To exit the protect mode, it is necessary to gate an input of the effected driver to the low logic state.

6367253 0101837 393

MC3481 MC3485

ELECTRICAL CHARACTERISTICS (Unless otherwise noted, these specifications apply over recommended power supply and temperature ratings. Typical values measured at $T_A = 25^\circ\text{C}$ and $V_{CC} = +5.0\text{ V}$)

Characteristic	Symbol	MC3481			MC3485			Unit
		Min	Typ	Max	Min	Typ	Max	
High-Level Input Voltage Note 2	V_{IH}	2.0	–	–	2.0	–	–	V
Low-Level Input Voltage Note 2	V_{IL}	–	–	0.8	–	–	0.8	V
High-Level Input Current ($V_{CC} = 4.5\text{ V}$, $V_{IH} = 2.7\text{ V}$) – Input Enable ($V_{CC} = 4.5\text{ V}$, $V_{IH} = 5.5\text{ V}$) – Input Enable	I_{IH}	–	–	20 40 100 200	–	–	20 80 100 400	μA
Low-Level Input Current ($V_{CC} = 5.95\text{ V}$, $V_{IL} = 0.4\text{ V}$) – Input Enable	I_{IL}	–	–	–250 –500	–	–	–250 –1000	μA
Input Clamp Voltage ($I_C = -18\text{ mA}$)	V_{IC}	–	–	–1.5	–	–	–1.5	V
High-Level Driver Output Voltage ($V_{CC} = 4.5\text{ V}$, $V_{IH} = 2.0\text{ V}$, $I_{OH} = -59.3\text{ mA}$) ($V_{CC} = 5.25\text{ V}$, $V_{IH} = 2.0\text{ V}$, $I_{OH} = -41\text{ mA}$)	$V_{OH(D)}$ $V_{OH(DS)}$	3.11 3.9	3.6 –	– –	3.11 3.9	3.6 –	– –	V
Low-Level Driver Output Voltage ($V_{CC} = 5.5\text{ V}$, $V_{IL} = 0.8\text{ V}$, $I_{OL} = -240\text{ }\mu\text{A}$) ($V_{CC} = 5.95\text{ V}$, $V_{IL} = 0.8\text{ V}$, $I_{OL} = -1.0\text{ mA}$)	$V_{OL(D)}$ $V_{OL(DS)}$	–	–	+0.15 +0.15	–	–	+0.15 +0.15	V
Driver Output Short Circuit Current ($V_{CC} = 5.5\text{ V}$, $V_{IH} = 2.0\text{ V}$, $V_{OS} = 0\text{ V}$) ($V_{CC} = 5.95\text{ V}$, $V_{IH} = 2.0\text{ V}$, $V_{OS} = 0\text{ V}$)	$I_{OS(D)}$ $I_{OS(DS)}$	–	–	–5.0 –5.0	–	–	–5.0 –5.0	mA
Driver Output Reverse Leakage Current ($V_{CC} = 4.5\text{ V}$, $V_{IL} = 0\text{ V}$, $V_O = 3.11\text{ V}$) ($V_{CC} = 0\text{ V}$, $V_{IL} = 0\text{ V}$, $V_O = 3.11\text{ V}$)	I_{OR1} I_{OR2}	–	–	+100 +200	–	–	+100 +200	μA
High-Level Driver Output Voltage ($V_{CC} = 4.5\text{ V}$, $V_{IL} = 0.8\text{ V}$, $I_{OH} = -400\text{ }\mu\text{A}$)	$V_{OH(D)}$	–	–	–	2.5	3.0	–	V
Low-Level Driver Output Voltage ($V_{CC} = 4.5\text{ V}$, $V_{IH} = 2.0\text{ V}$, $I_{OL} = 8.0\text{ mA}$)	$V_{OL(D)}$	–	–	–	–	–	0.5	V
Driver Output Short Circuit Current ($V_{CC} = 5.5\text{ V}$, $V_{OS} = 0\text{ V}$, only one output shorted at a time) ($V_{CC} = 5.95\text{ V}$, $V_{OS} = 0\text{ V}$, only one output shorted at a time)	$I_{OS(D)}$ $I_{OS(DS)}$	–	–	–	–15 –15	–60 –	–100 –110	mA
High-Level Fault Flag Output Voltage ($V_{CC} = 4.5\text{ V}$, $I_{OH} = -400\text{ }\mu\text{A}$)	$V_{OH(F)}$	2.5	3.0	–	–	–	–	V
Low-Level Fault Flag Output Voltage ($V_{CC} = 4.5\text{ V}$, $V_{IH} = 2.0\text{ V}$, $I_{OL} = 8.0\text{ mA}$, Driver Output shorted to Ground)	$V_{OL(F)}$	–	–	0.5	–	–	0.5	V
Fault Flag Output Short Circuit Current ($V_{CC} = 5.5\text{ V}$, $V_{OS} = 0\text{ V}$, only one output shorted at a time) ($V_{CC} = 5.95\text{ V}$, $V_{OS} = 0\text{ V}$, only one output shorted at a time)	$I_{OS(F)}$ $I_{OS(FS)}$	–15 –15	–	–100 –110	–	–	–	mA
High-Level Fault Flag Output Current ($V_{CC} = 5.95\text{ V}$, $V_{OH} = 5.95\text{ V}$)	$I_{OH(F)}$	–	–	–	–	–	+100	μA
High-Level Power Supply Current ($V_{CC} = 5.5\text{ V}$, $V_{IH} = 2.0\text{ V}$, no output loading) ($V_{CC} = 5.95\text{ V}$, $V_{IH} = 2.0\text{ V}$, no output loading)	I_{CCH} I_{CCHS}	–	50 –	70 80	–	55 –	75 85	mA
Low-Level Power Supply Current ($V_{CC} = 5.5\text{ V}$, $V_{IL} = 0.8\text{ V}$, no output loading) ($V_{CC} = 5.95\text{ V}$, $V_{IL} = 0.8\text{ V}$, no output loading)	I_{CCL} I_{CCLS}	–	35 –	55 70	–	35 –	55 70	mA

7

6367253 0101838 22T

MC3481 MC3485

Figure 1. MC3481 AC Test Circuit and Waveforms

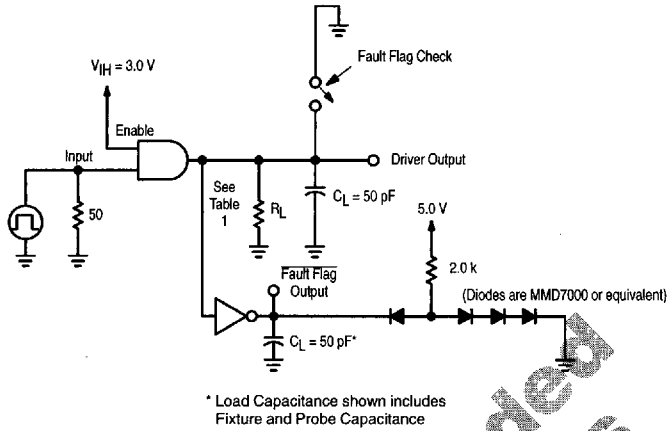
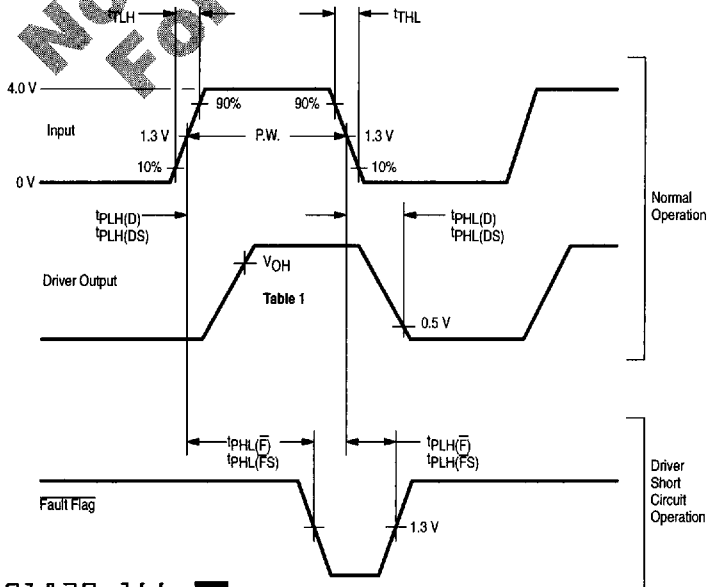

Table 1	Driver Application	
	I/O	Select-Out
V_{OH}	3.1 V	3.0 V
Input Frequency	0.5 MHz	1 MHz
Input Pulse Width	100 ns	500 ns
Input Amplitude	0 V to 4 V	0 V to 4 V
Input t_{TLH}	≤ 6 ns	≤ 6 ns
Input t_{TTL}	≤ 6 ns	≤ 6 ns
Load Resistance (R_L)	50	90



MC3481 MC3485

Figure 2. MC3485 AC Test Circuit and Waveforms

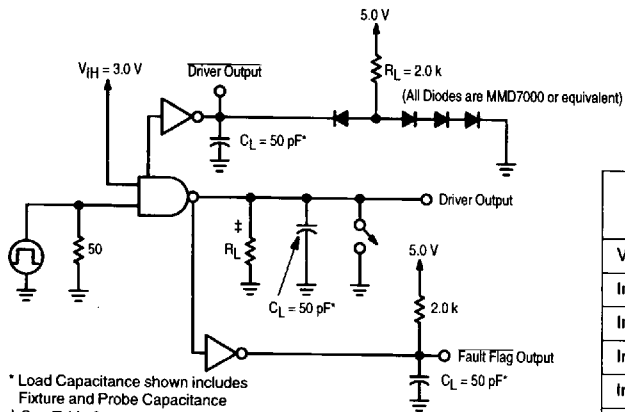
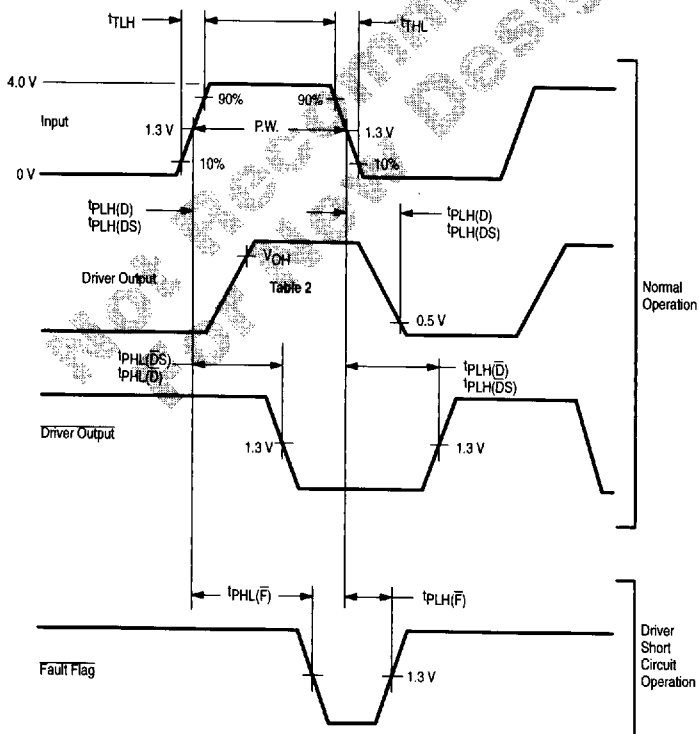

Table 2	Driver Application	
	I/O	Select-Out
VOH	3.11 V	3.9 V
Input Frequency	5 MHz	1 MHz
Input Pulse Width	100 ns	500 ns
Input Amplitude	0 V to 4 V	0 V to 4 V
Input t _{PLH}	≤ 6 ns	≤ 6 ns
Input t _{PHL}	≤ 6 ns	≤ 6 ns
Load Resistance (R _L)	50	90



7