

54ACQ/74ACQ563 • 54ACTQ/74ACTQ563 Quiet Series Octal Latch with TRI-STATE® Outputs

General Description

The 'ACQ/'ACTQ563 is a high speed octal latch with buffered common Latch Enable (LE) and buffered common Output Enable (\overline{OE}) inputs. The 'ACQ/'ACTQ563 is functionally identical to the 'ACQ/'ACTQ573, but with inverted outputs. The ACQ/ACTQ utilizes NSC Quiet Series technology to guarantee quiet output switching and improved dynamic threshold performance. FACT Quiet Series™ features GTO™ output control and undershoot corrector in addition to a split ground bus for superior performance.

Features

- Guaranteed simultaneous switching noise level and dynamic threshold performance
- Guaranteed pin-to-pin skew AC performance
- Improved latch-up immunity
- Inputs and outputs on opposite sides of package allow easy interface with microprocessors
- Outputs source/sink 24 mA
- Faster prop delays than standard ACT563
- Functionally identical to the ACQ/ACTQ573 but with inverted outputs
- 4 kV minimum ESD immunity

Ordering Code: See Section 8

Logic Symbols

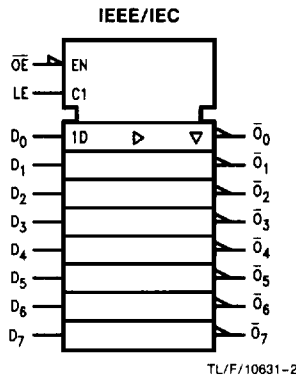
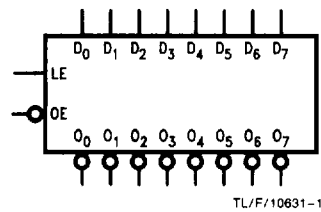

Connection Diagrams

Pin Assignment for DIP, Flatpak and SOIC

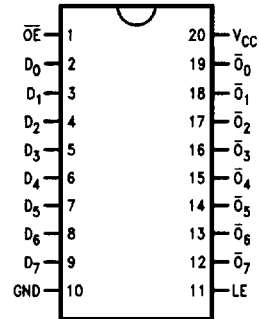

Pin Assignment for LCC

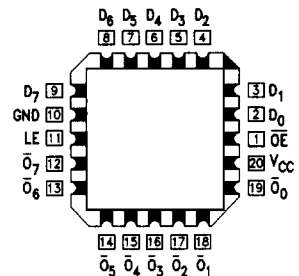

Pin Names	Description
D ₀ -D ₇	Data Inputs
LE	Latch Enable Input
\overline{OE}	TRI-STATE Output Enable Input
\overline{O}_0 - \overline{O}_7	TRI-STATE Latch Outputs

Functional Description

The 'ACQ/'ACTQ563 contains eight D-type latches with TRI-STATE complementary outputs. When the Latch Enable (LE) input is HIGH, data on the D_n inputs enters the latches. In this condition the latches are transparent, i.e., a latch output will change state each time its D input changes. When LE is LOW the latches store the information that was present on the D inputs a setup time preceding the HIGH-to-LOW transition of LE. The TRI-STATE buffers are controlled by the Output Enable (\overline{OE}) input. When \overline{OE} is LOW, the buffers are in the bi-state mode. When \overline{OE} is HIGH the buffers are in the high impedance mode but that does not interfere with entering new data into the latches.

Function Table

Inputs			Internal	Outputs	Function
\overline{OE}	LE	D	Q	O	
H	X	X	X	Z	High-Z
H	H	L	H	Z	High-Z
H	H	H	L	Z	High-Z
H	L	X	NC	Z	Latched
L	H	L	H	H	Transparent
L	H	H	L	L	Transparent
L	L	X	NC	NC	Latched

H = HIGH Voltage Level
 L = LOW Voltage Level
 X = Immaterial
 Z = High Impedance
 NC = No Change

Logic Diagram

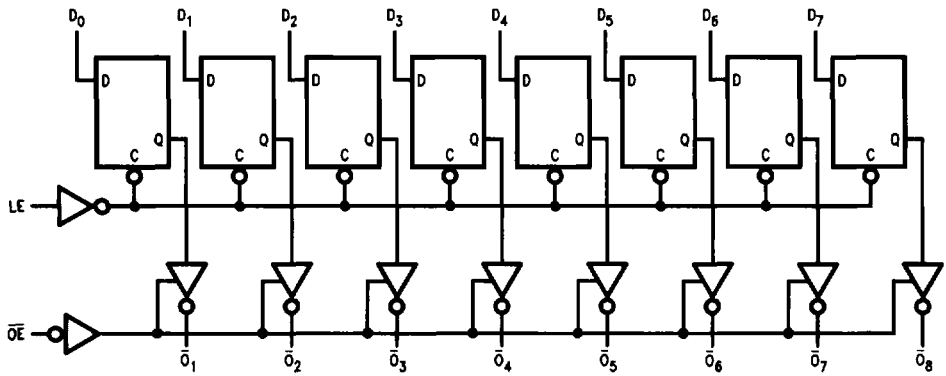

TL/F/10631-5

Please note that this diagram is provided only for the understanding of logic operations and should not be used to estimate propagation delays.

Absolute Maximum Rating (Note 1)

If Military/Aerospace specified devices are required, please contact the National Semiconductor Sales Office/Distributors for availability and specifications.

Supply Voltage (V_{CC})	-0.5V to +7.0V
DC Input Diode Current (I_{IK})	
$V_I = -0.5V$	-20 mA
$V_I = V_{CC} + 0.5V$	+20 mA
DC Input Voltage (V_I)	-0.5V to $V_{CC} + 0.5V$
DC Output Diode Current (I_{OK})	
$V_O = -0.5V$	-20 mA
$V_O = V_{CC} + 0.5V$	+20 mA
DC Output Voltage (V_O)	-0.5V to $V_{CC} + 0.5V$
DC Output Source or Sink Current (I_O)	±50 mA
DC V_{CC} or Ground Current per Output Pin (I_{CC} or I_{GND})	±50 mA
Storage Temperature (T_{STG})	-65°C to +150°C
DC Latchup Source or Sink Current	±300 mA
Junction Temperature (T_J)	
CDIP	175°C
PDIP	140°C

Note 1: Absolute maximum ratings are those values beyond which damage to the device may occur. The databook specifications should be met, without exception, to ensure that the system design is reliable over its power supply, temperature, and output/input loading variables. National does not recommend operation of FACT™ circuits outside databook specifications.

Recommended Operating Conditions

Supply Voltage (V_{CC})	
'ACQ	2.0V to 6.0V
'ACTQ	4.5V to 5.5V
Input Voltage (V_I)	0V to V_{CC}
Output Voltage (V_O)	0V to V_{CC}
Operating Temperature (T_A)	
74ACQ/ACTQ	-40°C to +85°C
54ACQ/ACTQ	-55°C to +125°C
Minimum Input Edge Rate $\Delta V/\Delta t$	
'ACQ Devices	
V_{IN} from 30% to 70% of V_{CC}	
V_{CC} @ 3.0V, 4.5V, 5.5V	125 mV/ns
Minimum Input Edge Rate $\Delta V/\Delta t$	
'ACTQ Devices	
V_{IN} from 0.8V to 2.0V	
V_{CC} @ 4.5V, 5.5V	125 mV/ns

DC Characteristics for 'ACQ Family Devices

Symbol	Parameter	V_{CC} (V)	74ACQ		54ACQ	74ACQ	Units	Conditions	
			$T_A = +25^\circ C$		$T_A =$ -55°C to +125°C	$T_A =$ -40°C to +85°C			
			Typ	Guaranteed Limits					
V_{IH}	Minimum High Level Input Voltage	3.0	1.5	2.1	2.1	2.1	V	$V_{OUT} = 0.1V$ or $V_{CC} - 0.1V$	
		4.5	2.25	3.15	3.15	3.15			
		5.5	2.75	3.85	3.85	3.85			
V_{IL}	Maximum Low Level Input Voltage	3.0	1.5	0.9	0.9	0.9	V	$V_{OUT} = 0.1V$ or $V_{CC} - 0.1V$	
		4.5	2.25	1.35	1.35	1.35			
		5.5	2.75	1.65	1.65	1.65			
V_{OH}	Minimum High Level Output Voltage	3.0	2.99	2.9	2.9	2.9	V	$I_{OUT} = -50 \mu A$	
		4.5	4.49	4.4	4.4	4.4			
		5.5	5.49	5.4	5.4	5.4			
			3.0		2.56	2.4	2.46	V	* $V_{IN} = V_{IL}$ or V_{IH} -12 mA I_{OH} -24 mA -24 mA
			4.5		3.86	3.7	3.76		
			5.5		4.86	4.7	4.76		
V_{OL}	Maximum Low Level Output Voltage	3.0	0.002	0.1	0.1	0.1	V	$I_{OUT} = 50 \mu A$	
		4.5	0.001	0.1	0.1	0.1			
		5.5	0.001	0.1	0.1	0.1			
			3.0		0.36	0.50	0.44	V	* $V_{IN} = V_{IL}$ or V_{IH} 12 mA I_{OL} 24 mA 24 mA
			4.5		0.36	0.50	0.44		
			5.5		0.36	0.50	0.44		

*All outputs loaded; thresholds on input associated with output under test.

†Maximum test duration 2.0 ms, one output loaded at a time.

DC Characteristics for 'ACQ Family Devices (Continued)

Symbol	Parameter	V _{CC} (V)	74ACQ		54ACQ	74ACQ	Units	Conditions
			T _A = +25°C		T _A = -55°C to +125°C	T _A = -40°C to +85°C		
			Typ	Guaranteed Limits				
I _{IN}	Maximum Input Leakage Current	5.5		±0.1	±1.0	±1.0	μA	V _I = V _{CC} , GND (Note 2)
I _{OLD}	†Minimum Dynamic Output Current	5.5			50	75	mA	V _{OLD} = 1.65V Max
I _{OHD}		5.5			-50	-75	mA	V _{OHD} = 3.85V Min
I _{CC}	Maximum Quiescent Supply Current	5.5		8.0	160.0	80.0	μA	V _{IN} = V _{CC} or GND (Note 1)
I _{OZ}	Maximum TRI-STATE Leakage Current	5.5		±0.5	±10.0	±5.0	μA	V _{I(OE)} = V _{IL} , V _{IH} V _I = V _{CC} , GND V _O = V _{CC} , GND
V _{OLP}	Quiet Output Maximum Dynamic V _{OL}	5.0	1.1	1.5			V	Figures 1, 2 (Notes 2, 3)
V _{OLV}	Quiet Output Minimum Dynamic V _{OL}	5.0	-0.6	-1.2			V	Figures 1, 2 (Notes 2, 3)
V _{IHD}	Minimum High Level Dynamic Input Voltage	5.0	3.1	3.5			V	(Notes 2, 4)
V _{ILD}	Maximum Low Level Dynamic Input Voltage	5.0	1.9	1.5			V	(Notes 2, 4)

*All outputs loaded; thresholds on input associated with output under test.

†Maximum test duration 2.0 ms, one output loaded at a time.

Note 1: I_{IN} and I_{CC} @ 3.0V are guaranteed to be less than or equal to the respective limit @ 5.5V V_{CC}.
I_{CC} for 54ACQ @ 25°C is identical to 74ACQ @ 25°C.

Note 2: Worst case package.

Note 3: Max number of outputs defined as (n). Data Inputs are driven 0V to 5V. One output @ GND.

Note 4: Maximum number of Data Inputs (n) switching. (n-1) Inputs switching 0V to 5V ('ACQ). Input-under-test switching: 5V to threshold (V_{ILD}), 0V to threshold (V_{IHD}). f = 1 MHz.

DC Characteristics for 'ACTQ Family Devices

Symbol	Parameter	V _{CC} (V)	74ACTQ		54ACTQ	74ACTQ	Units	Conditions
			T _A = +25°C		T _A = -55°C to +125°C	T _A = -40°C to +85°C		
			Typ	Guaranteed Limits				
V _{IH}	Minimum High Level Input Voltage	4.5	1.5	2.0	2.0	2.0	V	V _{OUT} = 0.1V or V _{CC} - 0.1V
		5.5	1.5	2.0	2.0	2.0		
V _{IL}	Maximum Low Level Input Voltage	4.5	1.5	0.8	0.8	0.8	V	V _{OUT} = 0.1V or V _{CC} - 0.1V
		5.5	1.5	0.8	0.8	0.8		
V _{OH}	Minimum High Level Output Voltage	4.5	4.49	4.4	4.4	4.4	V	I _{OUT} = -50 μA
		5.5	5.49	5.4	5.4	5.4		
		4.5		3.86	3.70	3.76	V	*V _{IN} = V _{IL} or V _{IH} -24 mA I _{OH} -24 mA
		5.5		4.86	4.70	4.76		
V _{OL}	Maximum Low Level Output Voltage	4.5	0.001	0.1	0.1	0.1		I _{OUT} = 50 μA
		5.5	0.001	0.1	0.1	0.1		
		4.5		0.36	0.50	0.44	V	*V _{IN} = V _{IL} or V _{IH} 24 mA I _{OL} 24 mA
		5.5		0.36	0.50	0.44		
I _{IN}	Maximum Input Leakage Current	5.5		±0.1	±1.0	±1.0	μA	V _I = V _{CC} , GND
I _{OZ}	Maximum TRI-STATE Leakage Current	5.5		±0.5	±10.0	±5.0	μA	V _I = V _{IL} , V _{IH} V _O = V _{CC} , GND
I _{CC1}	Maximum I _{CC} /Input	5.5	0.6		1.6	1.5	mA	V _I = V _{CC} - 2.1V
I _{OLD}	†Minimum Dynamic Output Current	5.5			50	75	mA	V _{OLD} = 1.65V Max
I _{OHD}	Maximum Dynamic Output Current	5.5			-50	-75	mA	V _{OHD} = 3.85V Min
I _{CC}	Maximum Quiescent Supply Current	5.5		8.0	160.0	80.0	μA	V _{IN} = V _{CC} or GND (Note 1)
V _{OLP}	Maximum High Level Output Noise	5.0	1.1	1.5			V	Figures 1, 2 (Notes 2, 3)
V _{OLV}	Maximum Low Level Output Noise	5.0	-0.6	-1.2			V	Figures 1, 2 (Note 2, 3)
V _{IHD}	Maximum High Level Dynamic Input Voltage	5.0	1.9	2.2			V	(Notes 2, 4)
V _{ILD}	Maximum Low Level Dynamic Input Voltage	5.0	1.2	0.8			V	(Notes 2, 4)

*All outputs loaded; thresholds on input associated with output under test.

†Maximum test duration 2.0 ms, one output loaded at a time.

Note 1: I_{CC} for 54ACTQ @ 25°C is identical to 74ACTQ @ 25°C.

Note 2: Worst case package.

Note 3: Max number of outputs defined as (n). Data inputs are driven 0V to 3V. One output @ GND.

Note 4: Max number of data inputs (n) switching. (n-1) inputs switching 0V to 3V ('ACTQ). Input-under-test switching; 3V to threshold (V_{ILD}), 0V to threshold (V_{IHD}).
f = 1 MHz.

AC Electrical Characteristics: See Section 2 for Waveforms

Symbol	Parameter	V _{CC} * (V)	74ACQ			54ACQ		74ACQ		Units	Fig. No.
			T _A = +25°C C _L = 50 pF			T _A = -55°C to +125°C C _L = 50 pF		T _A = -40°C to +85°C C _L = 50 pF			
			Min	Typ	Max	Min	Max	Min	Max		
t _{PHL} , t _{PLH}	Propagation Delay D _n to O _n	3.3 5.0	2.5 1.5	8.5 5.5	11.5 7.5			2.5 1.5	12.0 8.0	ns	2-3, 4
t _{PLH} , t _{PHL}	Propagation Delay LE to O _n	3.3 5.0	2.5 2.0	8.5 6.0	13.0 8.5			2.5 2.0	13.5 9.0	ns	2-3, 4
t _{PZL} , t _{PZH}	Output Enable Time	3.3 5.0	2.5 1.5	8.5 6.0	13.0 8.5			2.5 1.5	13.5 9.0	ns	2-5, 6
t _{PHZ} , t _{PLZ}	Output Disable Time	3.3 5.0	1.0 1.0	9.0 6.5	14.5 9.5			1.0 1.0	15.0 10.0	ns	2-5, 6
t _{OSSL} , t _{OSLH}	Output to Output Skew** D _n to O _n	3.3 5.0		1.0 0.5	1.5 1.0				1.5 1.0	ns	

*Voltage Range 5.0 is 5.0V ± 0.5V

Voltage Range 3.3 is 3.3V ± 0.3V

Skew is defined as the absolute value of the difference between the actual propagation delay for any two separate outputs of the same device. The specification applies to any outputs switching in the same direction, either HIGH to LOW (t_{OSSL}) or LOW to HIGH (t_{OSLH}). Parameter guaranteed by design.AC Operating Requirements:** See Section 2 for Waveforms

Symbol	Parameter	V _{CC} * (V)	74ACQ		54ACQ		74ACQ		Units	Fig. No.
			T _A = +25°C C _L = 50 pF		T _A = -55°C to +125°C C _L = 50 pF		T _A = -40°C to +85°C C _L = 50 pF			
			Typ	Guaranteed Minimum						
t _S	Setup Time, HIGH or LOW D _n to LE	3.3 5.0	0 0	3.0 3.0			3.0 3.0		ns	2-7
t _H	Hold Time, HIGH or LOW D _n to LE	3.3 5.0	0 0	1.5 1.5			1.5 1.5		ns	2-7
t _W	LE Pulse Width, HIGH	3.3 5.0	2.0 2.0	4.0 4.0			4.0 4.0		ns	2-3

*Voltage Range 5.0 is 5.0V ± 0.5V

Voltage Range 3.3V is 3.3 ± 0.3V

AC Electrical Characteristics: See Section 2 for Waveforms

Symbol	Parameter	V _{CC} * (V)	74ACTQ			54ACTQ		74ACTQ		Units	Fig. No.
			T _A = +25°C C _L = 50 pF			T _A = -55°C to +125°C C _L = 50 pF		T _A = -40°C to +85°C C _L = 50 pF			
			Min	Typ	Max	Min	Max	Min	Max		
t _{PHL} , t _{PLH}	Propagation Delay D _n to O _n	5.0	2.0	6.0	8.0			2.0	8.5	ns	2-3, 4
t _{PLH} , t _{PHL}	Propagation Delay LE to O _n	5.0	2.5	7.0	9.0			2.5	9.5	ns	2-3, 4
t _{PZL} , t _{PZH}	Output Enable Time	5.0	2.0	7.0	9.0			2.0	9.5	ns	2-5, 6
t _{PHZ} , t _{PHL}	Output Disable Time	5.0	1.0	8.0	10.0			1.0	10.5	ns	2-5, 6
t _{OSSL} , t _{OSLH}	Output to Output Skew** D _n to O _n	5.0		0.5	1.0				1.0	ns	

*Voltage Range 5.0 is 5.0V ± 0.5V

**Skew is defined as the absolute value of the difference between the actual propagation delay for any two separate outputs of the same device. The specification applies to any outputs switching in the same direction, either HIGH to LOW (t_{OSSL}) or LOW to HIGH (t_{OSLH}). Parameter guaranteed by design.

AC Operating Requirements: See Section 2 for Waveforms

Symbol	Parameter	V _{CC} * (V)	74ACTQ		54ACTQ	74ACTQ	Units	Fig. No.
			T _A = +25°C C _L = 50 pF		T _A = -55°C to +125°C C _L = 50 pF	T _A = -40°C to +85°C C _L = 50 pF		
			Typ	Guaranteed Minimum				
t _S	Setup Time, HIGH or LOW D _n to LE	5.0	0	3.0		3.0	ns	2-7
t _H	Hold Time, HIGH or LOW D _n to LE	5.0	0	1.5		1.5	ns	2-7
t _W	LE Pulse Width, HIGH	5.0	2.0	4.0		4.0	ns	2-3

*Voltage Range 5.0 is 5.0V ±0.5V

Capacitance

Symbol	Parameter	Typ	Units	Conditions
C _{IN}	Input Capacitance	4.5	pF	V _{CC} = 5.0V
C _{PD}	Power Dissipation Capacitance	42	pF	V _{CC} = 5.0V