

National Semiconductor is now part of
Texas Instruments.

Search <http://www.ti.com/> for the latest technical
information and details on our current products and services.

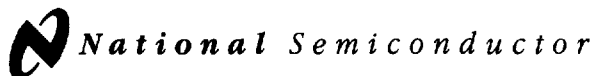

DS26LS31C/DS26LS31M Quad High Speed Differential Line Driver

General Description

The DS26LS31 is a quad differential line driver designed for digital data transmission over balanced lines. The DS26LS31 meets all the requirements of EIA Standard RS-422 and Federal Standard 1020. It is designed to provide unipolar differential drive to twisted-pair or parallel-wire transmission lines.

The circuit provides an enable and disable function common to all four drivers. The DS26LS31 features TRI-STATE® outputs and logically ANDed complementary outputs. The inputs are all LS compatible and are all one unit load.

Features

- Output skew—2.0 ns typical
- Input to output delay—10 ns typical
- Operation from single 5V supply
- Outputs won't load line when $V_{CC} = 0V$
- Four line drivers in one package for maximum package density
- Output short-circuit protection
- Complementary outputs
- Meets the requirements of EIA Standard RS-422
- Pin compatible with AM26LS31
- Available in military and commercial temperature range

Logic and Connection Diagrams

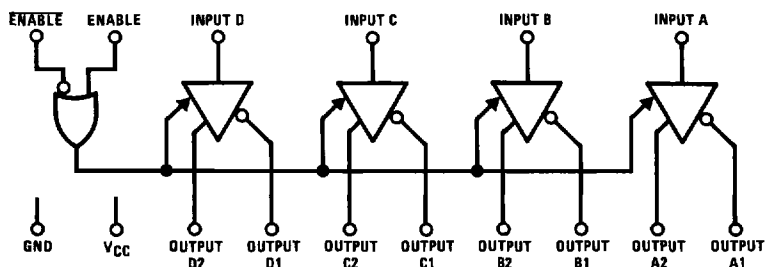

TL/F/5778-1

Dual-In-Line Package

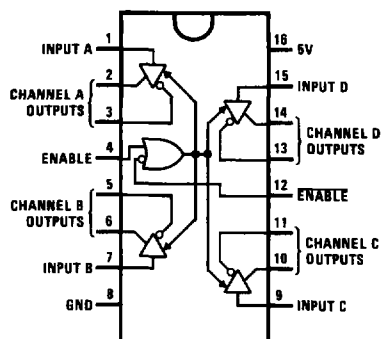

TL/F/5778-2

Top View

Order Number DS26LS31CJ, DS26LS31CM,
DS26LS31CN or DS26LS31MJ
See NS Package Number J16A, M16A or N16A

For Complete Military 883 Specifications, see RETS Data Sheet.
Order Number DS26LS31MJ/883 or DS26LS31MW/883
See NS Package J16A or W16A

Absolute Maximum Ratings (Note 1)

If Military/Aerospace specified devices are required, please contact the National Semiconductor Sales Office/Distributors for availability and specifications.

Supply Voltage	7V
Input Voltage	7V
Output Voltage	5.5V
Output Voltage (Power OFF)	-0.25 to 6V

Maximum Power Dissipation* at 25°C

Cavity Package	1509 mW
Molded DIP Package	1476 mW
SO Package	1051 mW

*Derate cavity package 10.1 mW/°C above 25°C; derate molded DIP package 11.9 mW/°C above 25°C; derate SO package 8.41 mW/°C above 25°C.

Operating Conditions

	Min	Max	Units
Supply Voltage, V_{CC}			
DS26LS31M	4.5	5.5	V
DS26LS31	4.75	5.25	V
Temperature, T_A			
DS26LS31M	-55	+125	°C
DS26LS31	0	+70	°C

Electrical Characteristics (Notes 2, 3 and 4)

Symbol	Parameter	Conditions	Min	Typ	Max	Units
V_{OH}	Output High Voltage	$I_{OH} = -20$ mA	2.5			V
V_{OL}	Output Low Voltage	$I_{OL} = 20$ mA			0.5	V
V_{IH}	Input High Voltage		2.0			V
V_{IL}	Input Low Voltage				0.8	V
I_{IL}	Input Low Current	$V_{IN} = 0.4$ V		-40	-200	μ A
I_{IH}	Input High Current	$V_{IN} = 2.7$ V			20	μ A
I_I	Input Reverse Current	$V_{IN} = 7$ V			0.1	mA
I_O	TRI-STATE Output Current	$V_O = 2.5$ V			20	μ A
		$V_O = 0.5$ V			-20	μ A
V_{CL}	Input Clamp Voltage	$I_{IN} = -18$ mA			-1.5	V
I_{SC}	Output Short-Circuit Current		-30		-150	mA
I_{CC}	Power Supply Current	All Outputs Disabled or Active		35	60	mA

Switching Characteristics $V_{CC} = 5$ V, $T_A = 25^\circ$ C

Symbol	Parameter	Conditions	Min	Typ	Max	Units
t_{PLH}	Input to Output	$C_L = 30$ pF		10	15	ns
t_{PHL}	Input to Output	$C_L = 30$ pF		10	15	ns
Skew	Output to Output	$C_L = 30$ pF		2.0	6.0	ns
t_{LZ}	Enable to Output	$C_L = 10$ pF, S2 Open		15	35	ns
t_{HZ}	Enable to Output	$C_L = 10$ pF, S1 Open		15	25	ns
t_{ZL}	Enable to Output	$C_L = 30$ pF, S2 Open		20	30	ns
t_{ZH}	Enable to Output	$C_L = 30$ pF, S1 Open		20	30	ns

Note 1: "Absolute Maximum Ratings" are those values beyond which the safety of the device cannot be guaranteed. They are not meant to imply that the devices should be operated at these limits. The tables of "Electrical Characteristics" provide conditions for actual device operation.

Note 2: Unless otherwise specified min/max limits apply across the -55°C to +125°C temperature range for the DS726LS31M and across the 0°C to +70°C range for the DS26LS31. All typicals are given for $V_{CC} = 5$ V and $T_A = 25^\circ$ C.

Note 3: All currents into device pins are positive; all currents out of device pins are negative. All voltages are referenced to ground unless otherwise specified.

Note 4: Only one output at a time should be shorted.

AC Test Circuit and Switching Time Waveforms

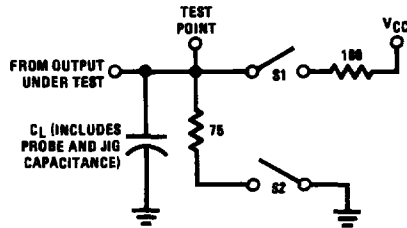

Note: S1 and S2 of load circuit are closed except where shown.

TL/F/5778-3

FIGURE 1. AC Test Circuit

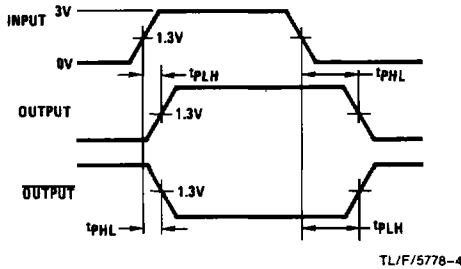

$f = 1 \text{ MHz}, t_r \leq 15 \text{ ns}, t_f \leq 6 \text{ ns}$

FIGURE 2. Propagation Delays

TL/F/5778-4

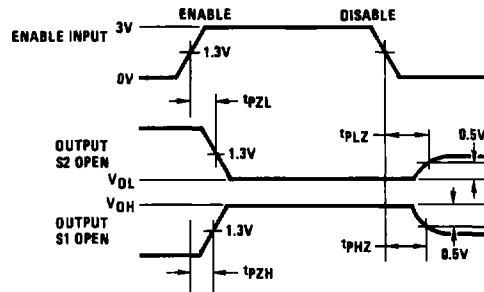

$f = 1 \text{ MHz}, t_r \leq 15 \text{ ns}, t_f \leq 6 \text{ ns}$

FIGURE 3. Enable and Disable Times

TL/F/5778-5

Typical Applications

Two-Wire Balanced System, RS-422

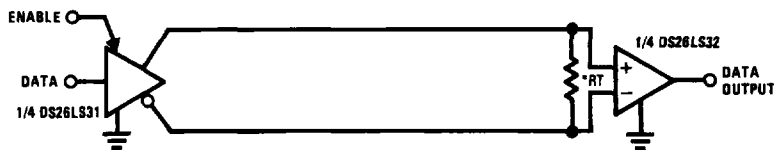

*RT is optional although highly recommended to reduce reflection.

TL/F/5778-6

Typical Performance Characteristics

DS26LS31CN Unloaded I_C vs Frequency vs T_A

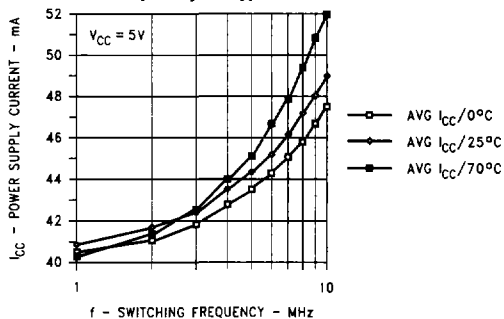

TL/F/5778-7

DS26LS31 I_{CC} vs V_{CC} vs T_A

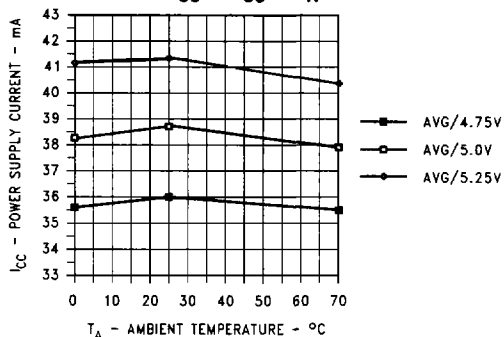

TL/F/5778-8

DS26LS31CN V_{OH} vs I_{OH} vs T_A

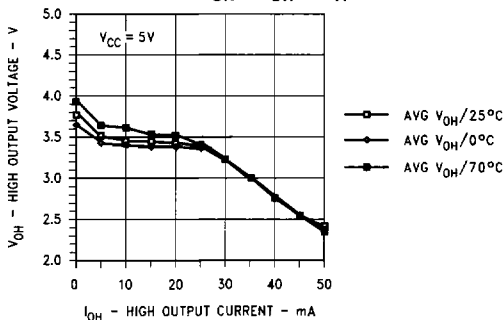

TL/F/5778-9

DS26LS31CN V_{OL} vs I_{OL} vs T_A

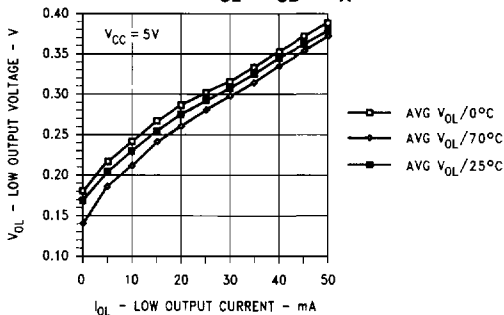

TL/F/5778-10

DS26LS31CN V_{OD} vs I_O vs T_A

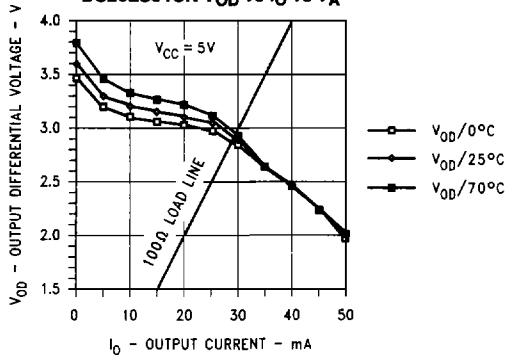

TL/F/5778-11