

DATA SHEET

74LV163

Presetable synchronous 4-bit binary counter; synchronous reset

Product specification

1997 Feb 12

IC24 Data Handbook

Presettable synchronous 4-bit binary counter; synchronous reset

74LV163

FEATURES

- Wide operating voltage: 1.0 to 5.5 V
- Optimized for low voltage applications: 1.0 to 3.6 V
- Accepts TTL input levels between $V_{CC} = 2.7$ V and $V_{CC} = 3.6$ V
- Typical V_{OLP} (output ground bounce) < 0.8 V at $V_{CC} = 3.3$ V, $T_{amb} = 25^{\circ}\text{C}$
- Typical V_{OHV} (output V_{OH} undershoot) > 2 V at $V_{CC} = 3.3$ V, $T_{amb} = 25^{\circ}\text{C}$
- Synchronous counting and loading
- Two count enable inputs for n-bit cascading
- Positive-edge triggered clock
- Synchronous reset
- Output capability: standard
- I_{CC} category: MSI

DESCRIPTION

The 74LV163 is a low-voltage Si-gate CMOS device and is pin and function compatible with 74HC/HCT163.

The 74LV163 is a synchronous presettable binary counter which features an internal look-head carry and can be used for high-speed

counting. Synchronous operation is provided by having all flip-flops clocked simultaneously on the positive-going edge of the clock (CP). The outputs (Q_0 to Q_3) of the counters may be preset to a HIGH or LOW level. A LOW level at the parallel enable input (PE) disables the counting action and causes the data at the data inputs (D_0 to D_3) to be loaded into the counter on the positive-going edge of the clock (providing that the set-up and hold time requirements for PE are met). Preset takes place regardless of the levels at count enable inputs (CEP and CET). A low level at the master reset input (\overline{MR}) sets all four outputs of the flip-flops (Q_0 to Q_3) to LOW level after the next positive-going transition on the clock (CP) input (provided that the set-up and hold time requirements for \overline{MR} are met).

This action occurs regardless of the levels at PE, CET and CEP inputs. This synchronous reset feature enables the designer to modify the maximum count with only one external NAND gate. The look ahead carry simplifies serial cascading of the counters. Both count enable inputs (CEP and CET) must be HIGH to count. The CET input is fed forward to enable the terminal count output (TC). The TC output thus enabled will produce a HIGH output pulse of a duration approximately equal to a HIGH level output of Q_0 . This pulse can be used to enable the next cascading stage. The maximum clock frequency for the cascaded counters is determined by the CP to TC propagation delay and CEP to CP set-up time, according to the following formula:

$$f_{max} = \frac{1}{t_{p(max)}(CP \text{ to } TC) + t_{su}(CEP \text{ to } CP)}$$

QUICK REFERENCE DATA

GND = 0 V; $T_{amb} = 25^{\circ}\text{C}$; $t_r = t_f \leq 2.5$ ns

SYMBOL	PARAMETER	CONDITIONS	TYPICAL	UNIT
t_{PHL}/t_{PLH}	Propagation delay CP to Q_n CP to TC CET to TC	$C_L = 15$ pF; $V_{CC} = 3.3$ V	15 18 9	ns
f_{max}	Maximum clock frequency		77	MHz
C_I	Input capacitance		3.5	pF
C_{PD}	Power dissipation capacitance per gate	$V_I = \text{GND to } V_{CC}^1$	25	pF

NOTES:

1. C_{PD} is used to determine the dynamic power dissipation (P_D in μW)
 $P_D = C_{PD} \times V_{CC}^2 \times f_i + \sum (C_L \times V_{CC}^2 \times f_o)$ where:
 f_i = input frequency in MHz; C_L = output load capacity in pF;
 f_o = output frequency in MHz; V_{CC} = supply voltage in V;
 $\sum (C_L \times V_{CC}^2 \times f_o)$ = sum of the outputs.

ORDERING INFORMATION

PACKAGES	TEMPERATURE RANGE	OUTSIDE NORTH AMERICA	NORTH AMERICA	PKG. DWG. #
16-Pin Plastic DIL	-40°C to +125°C	74LV163 N	74LV163 N	SOT38-4
16-Pin Plastic SO	-40°C to +125°C	74LV163 D	74LV163 D	SOT109-1
16-Pin Plastic SSOP Type II	-40°C to +125°C	74LV163 DB	74LV163 DB	SOT338-1
16-Pin Plastic TSSOP Type I	-40°C to +125°C	74LV163 PW	74LV163PW DH	SOT403-1

Pre-settable synchronous 4-bit binary counter; synchronous reset

74LV163

PIN CONFIGURATION

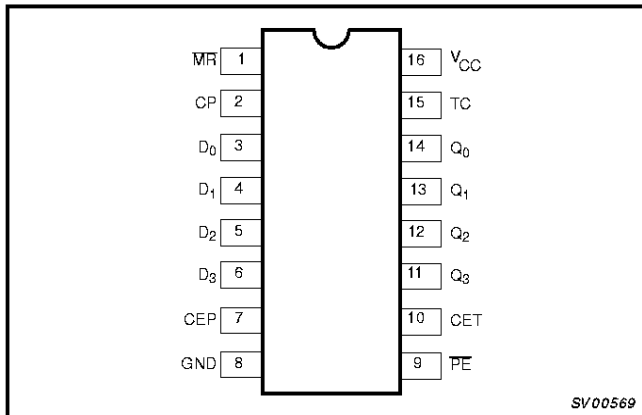

LOGIC SYMBOL

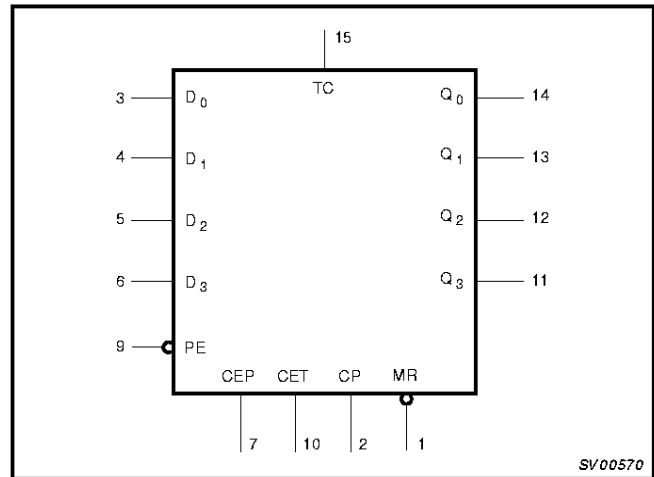

PIN DESCRIPTION

PIN NUMBER	SYMBOL	FUNCTION
1	MR	Asynchronous master reset (active LOW)
2	CP	Clock input (LOW-to-HIGH, edge-triggered)
3, 4, 5, 6	D ₀ to D ₃	Data inputs
7	CEP	Count enable inputs
8	GND	Ground (0 V)
9	PE	Parallel enable input (active LOW)
10	CET	Count enable carry input
14, 13, 12, 11	Q ₀ to Q ₃	Flip-flop outputs
15	TC	Terminal count output
16	V _{CC}	Positive supply voltage

FUNCTIONAL DIAGRAM

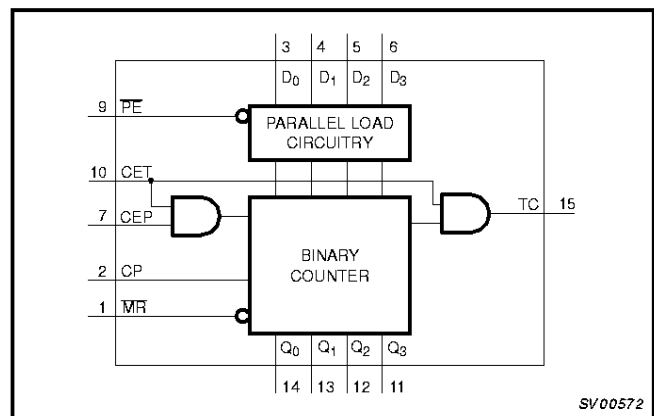

LOGIC SYMBOL (IEEE/IEC)

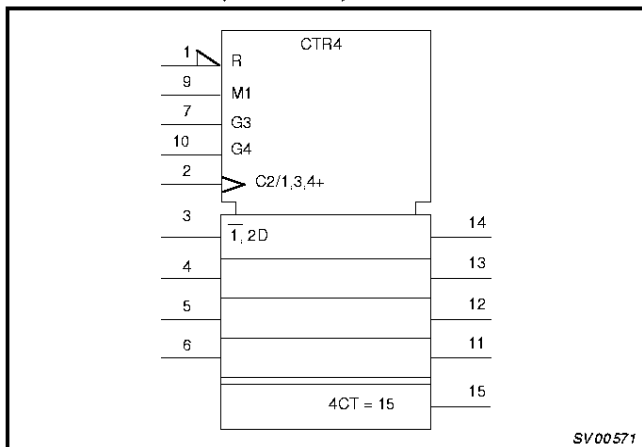

Presettable synchronous 4-bit binary counter; synchronous reset

74LV163

FUNCTION TABLE

OPERATING MODES	INPUTS						OUTPUTS	
	MR	CP	CEP	CET	PE	D _n	Q _n	TC
Reset (clear)	l	↑	X	X	X	X	L	L
Parallel load	h	↑	X	X	l	l	L	L
	h	↑	X	X	l	h	H	*
Count	h	↑	h	h	h	X	Count	*
Hold (do nothing)	h	X	l	X	h	X	q _n	*
	h	X	X	l	h	X	q _n	L

NOTES:

- * = The TC output is HIGH when CET is HIGH and the counter is at terminal count (HHHH)
- H = HIGH voltage level
- h = HIGH voltage level one set-up time prior to the LOW-to-HIGH clock transition
- L = LOW voltage level
- l = LOW voltage level one set-up time prior to the LOW-to-HIGH clock transition
- q = lower case letters indicate the state of the referenced output one set-up time prior to the LOW-to-HIGH clock transition
- X = don't care
- ↑ = LOW-to-HIGH clock transition

STATE DIAGRAM

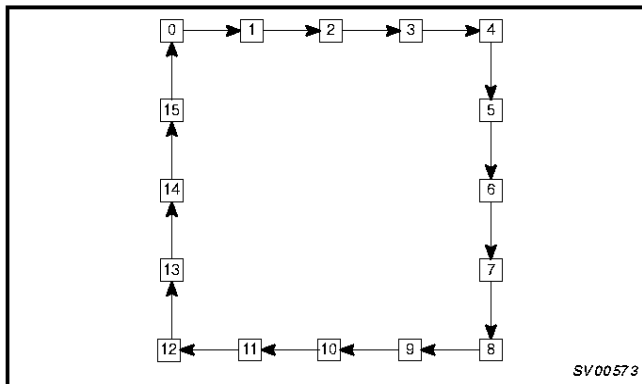

TYPICAL TIMING SEQUENCE

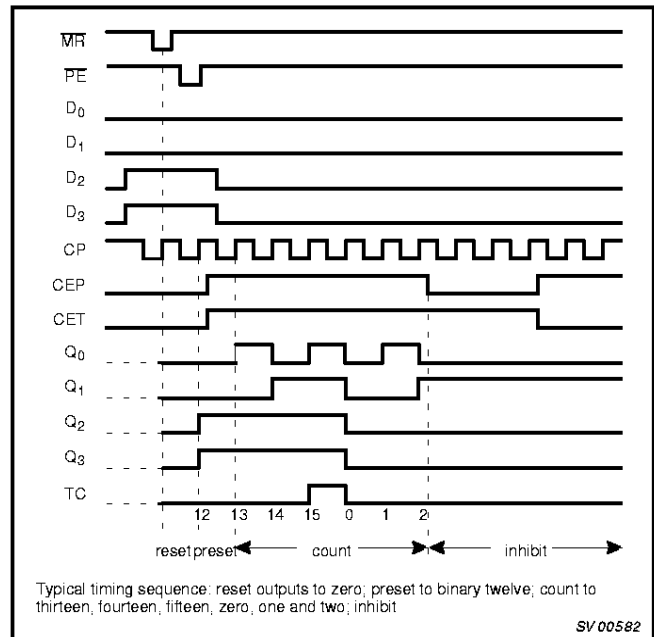

Presettable synchronous 4-bit binary counter; synchronous reset

74LV163

LOGIC DIAGRAM

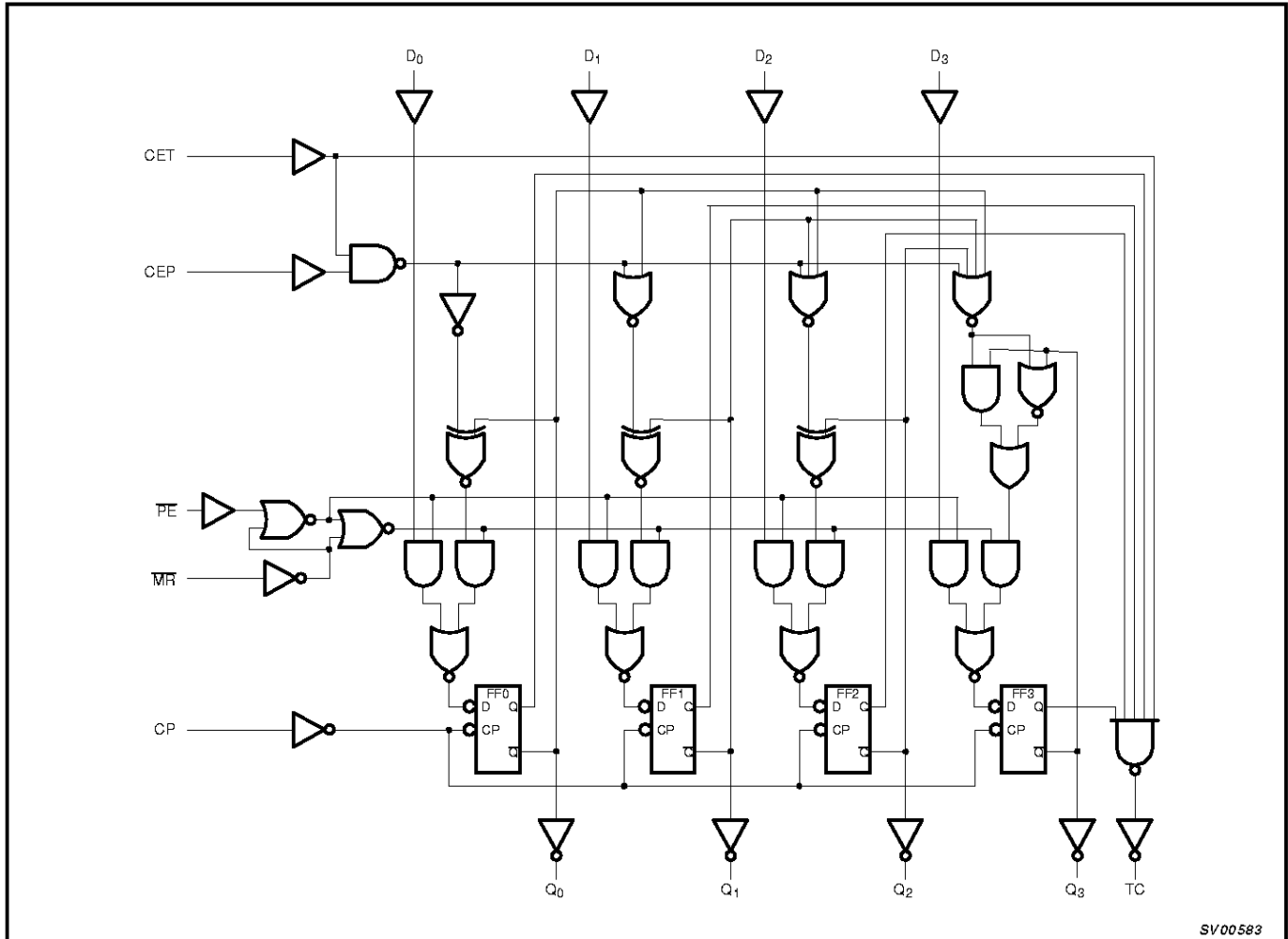

SV00583

Presetable synchronous 4-bit binary counter; synchronous reset

74LV163

RECOMMENDED OPERATING CONDITIONS

SYMBOL	PARAMETER	CONDITIONS	MIN	TYP	MAX	UNIT
V_{CC}	DC supply voltage	See Note 1	1.0	3.3	5.5	V
V_I	Input voltage		0	–	V_{CC}	V
V_O	Output voltage		0	–	V_{CC}	V
T_{amb}	Operating ambient temperature range in free air	See DC and AC characteristics per device	–40 –40		+85 +125	°C
t_r, t_f	Input rise and fall times except for Schmitt-trigger inputs	$V_{CC} = 1.0V$ to $2.0V$ $V_{CC} = 2.0V$ to $2.7V$ $V_{CC} = 2.7V$ to $3.6V$ $V_{CC} = 3.6V$ to $5.5V$	– – – –	– – – –	500 200 100 50	ns/V

NOTE:

- The LV is guaranteed to function down to $V_{CC} = 1.0V$ (input levels GND or V_{CC}); DC characteristics are guaranteed from $V_{CC} = 1.2V$ to $V_{CC} = 5.5V$.

ABSOLUTE MAXIMUM RATINGS^{1, 2}

In accordance with the Absolute Maximum Rating System (IEC 134).

Voltages are referenced to GND (ground = 0 V).

SYMBOL	PARAMETER	CONDITIONS	RATING	UNIT
V_{CC}	DC supply voltage		–0.5 to +7.0	V
$\pm I_{IK}$	DC input diode current	$V_I < -0.5$ or $V_I > V_{CC} + 0.5V$	20	mA
$\pm I_{OK}$	DC output diode current	$V_O < -0.5$ or $V_O > V_{CC} + 0.5V$	50	mA
$\pm I_O$	DC output source or sink current – standard outputs – bus driver outputs	$-0.5V < V_O < V_{CC} + 0.5V$	25 35	mA
$\pm I_{GND}, \pm I_{CC}$	DC V_{CC} or GND current for types with – standard outputs – bus driver outputs		50 70	mA
T_{stg}	Storage temperature range		–65 to +150	°C
P_{TOT}	Power dissipation per package – plastic DIL – plastic mini-pack (SO) – plastic shrink mini-pack (SSOP and TSSOP)	for temperature range: –40 to +125°C above +70°C derate linearly with 12 mW/K above +70°C derate linearly with 8 mW/K above +60°C derate linearly with 5.5 mW/K	750 500 400	mW

NOTES:

- Stresses beyond those listed may cause permanent damage to the device. These are stress ratings only and functional operation of the device at these or any other conditions beyond those indicated under “recommended operating conditions” is not implied. Exposure to absolute-maximum-rated conditions for extended periods may affect device reliability.
- The input and output voltage ratings may be exceeded if the input and output current ratings are observed.

Pre-settable synchronous 4-bit binary counter; synchronous reset

74LV163

DC ELECTRICAL CHARACTERISTICS

Over recommended operating conditions. Voltages are referenced to GND (ground = 0 V).

SYMBOL	PARAMETER	TEST CONDITIONS	LIMITS					UNIT
			-40°C to +85°C			-40°C to +125°C		
			MIN	TYP ¹	MAX	MIN	MAX	
V _{IH}	HIGH level Input voltage	V _{CC} = 1.2 V	V _{CC}	0.6		V _{CC}		V
		V _{CC} = 2.0 V	1.4			1.4		
		V _{CC} = 2.7 to 3.6 V	2.0			2.0		
		V _{CC} = 4.5 to 5.5 V	0.7 * V _{CC}			0.7 * V _{CC}		
V _{IL}	LOW level Input voltage	V _{CC} = 1.2 V		0.4	GND		GND	V
		V _{CC} = 2.0 V			0.6		0.6	
		V _{CC} = 2.7 to 3.6 V			0.8		0.8	
		V _{CC} = 4.5 to 5.5			0.3 * V _{CC}		0.3 * V _{CC}	
V _{OH}	HIGH level output voltage; all outputs	V _{CC} = 1.2 V; V _I = V _{IH} or V _{IL} ; -I _O = 100µA		1.2				V
		V _{CC} = 2.0 V; V _I = V _{IH} or V _{IL} ; -I _O = 100µA	1.8	2.0		1.8		
		V _{CC} = 2.7 V; V _I = V _{IH} or V _{IL} ; -I _O = 100µA	2.5	2.7		2.5		
		V _{CC} = 3.0 V; V _I = V _{IH} or V _{IL} ; -I _O = 100µA	2.8	3.0		2.8		
		V _{CC} = 4.5 V; V _I = V _{IH} or V _{IL} ; -I _O = 100µA	4.3	4.5		4.3		
V _{OH}	HIGH level output voltage; STANDARD outputs	V _{CC} = 3.0 V; V _I = V _{IH} or V _{IL} ; -I _O = 6mA	2.40	2.82		2.20		V
		V _{CC} = 4.5 V; V _I = V _{IH} or V _{IL} ; -I _O = 12mA	3.60	4.20		3.50		
V _{OH}	HIGH level output voltage; BUS driver outputs	V _{CC} = 3.0 V; V _I = V _{IH} or V _{IL} ; -I _O = 8mA	2.40	2.82		2.20		V
		V _{CC} = 4.5 V; V _I = V _{IH} or V _{IL} ; -I _O = 16mA	3.60	4.20		3.50		
V _{OL}	LOW level output voltage; all outputs	V _{CC} = 1.2 V; V _I = V _{IH} or V _{IL} ; I _O = 100µA		0				V
		V _{CC} = 2.0 V; V _I = V _{IH} or V _{IL} ; I _O = 100µA		0	0.2		0.2	
		V _{CC} = 2.7 V; V _I = V _{IH} or V _{IL} ; I _O = 100µA		0	0.2		0.2	
		V _{CC} = 3.0 V; V _I = V _{IH} or V _{IL} ; I _O = 100µA		0	0.2		0.2	
		V _{CC} = 4.5 V; V _I = V _{IH} or V _{IL} ; I _O = 100µA		0	0.2		0.2	
V _{OL}	LOW level output voltage; STANDARD outputs	V _{CC} = 3.0 V; V _I = V _{IH} or V _{IL} ; I _O = 6mA		0.25	0.40		0.50	V
		V _{CC} = 4.5 V; V _I = V _{IH} or V _{IL} ; I _O = 12mA		0.35	0.55		0.65	
V _{OL}	LOW level output voltage; BUS driver outputs	V _{CC} = 3.0 V; V _I = V _{IH} or V _{IL} ; I _O = 8mA		0.20	0.40		0.50	V
		V _{CC} = 4.5 V; V _I = V _{IH} or V _{IL} ; I _O = 16mA		0.35	0.55		0.65	
I _I	Input leakage current	V _{CC} = 5.5 V; V _I = V _{CC} or GND			1.0		1.0	µA
I _{oz}	3-State output OFF-state current	V _{CC} = 5.5 V; V _I = V _{IH} or V _{IL} ; V _O = V _{CC} or GND			5		10	µA
I _{CC}	Quiescent supply current; SSI	V _{CC} = 5.5V; V _I = V _{CC} or GND; I _O = 0			20.0		40	µA
	Quiescent supply current; flip-flops	V _{CC} = 5.5V; V _I = V _{CC} or GND; I _O = 0			20.0		80	
	Quiescent supply current; MSI	V _{CC} = 5.5 V; V _I = V _{CC} or GND; I _O = 0			20.0		160	µA
	Quiescent supply current; LSI	V _{CC} = 5.5 V; V _I = V _{CC} or GND; I _O = 0			500		1000	
ΔI _{CC}	Additional quiescent supply current per input	V _{CC} = 2.7 V to 3.6 V; V _I = V _{CC} - 0.6 V			500		850	µA

NOTE:

1. All typical values are measured at T_{amb} = 25°C.

Pre-settable synchronous 4-bit binary counter; synchronous reset

74LV163

AC CHARACTERISTICSGND = 0V; $t_r = t_f = 2.5\text{ns}$; $C_L = 50\text{pF}$; $R_L = 500\Omega$

SYMBOL	PARAMETER	WAVEFORM	CONDITION	LIMITS					UNIT
				-40 to +85 °C			-40 to +125 °C		
				V _{CC} (V)	MIN	TYP ¹	MAX	MIN	
t _{PHL} /t _{PLH}	Propagation delay CP to Q _n	Figures 1, 6	1.2		95				ns
			2.0		32	61		75	
			2.7		24	45		55	
			3.0 to 3.6		18 ²	36		44	
t _{PHL} /t _{PLH}	Propagation delay CP to TC	Figures 1, 6	1.2		115				ns
			2.0		39	75		90	
			2.7		29	55		66	
			3.0 to 3.6		22 ²	44		53	
t _{PHL} /t _{PLH}	Propagation delay CET to TC	Figures 2, 6	1.2		55				ns
			2.0		19	36		44	
			2.7		14	26		33	
			3.0 to 3.6		10 ²	21		26	
t _w	Clock pulse width HIGH or LOW	Figures 1, 6	2.0	34	10		41		ns
			2.7	25	8		30		
			3.0 to 3.6	20	6 ²		24		
t _{su}	Set-up time MR, D _n to CP	Figures 3, 4, 6	1.2		25				ns
			2.0	22	9		26		
			2.7	16	6		19		
			3.0 to 3.6	13	5 ²		15		
t _{su}	Set-up time PE to CP	Figures 3, 6	1.2		30				ns
			2.0	22	10		26		
			2.7	16	8		19		
			3.0 to 3.6	13	6 ²		15		
t _{su}	Set-up time CEP, CET to CP	Figures 5, 6	1.2		30				ns
			2.0	22	10		26		
			2.7	16	8		19		
			3.0 to 3.6	13	6 ²		15		
t _h	Hold time D _n , PE, CEP, CET, MR to CP	Figures 3, 4, 5, 6	1.2		-35				ns
			2.0	0	-12		0		
			2.7	0	-9		0		
			3.0 to 3.6	0	-7		0		
f _{max}	Maximum clock pulse frequency	Figures 1, 6	2.0	14	40		12		MHz
			2.7	19	58		16		
			3.0 to 3.6	24	70		20		

NOTES:

1. Unless otherwise stated, all typical values are measured at T_{amb} = 25°C
2. Typical values are measured at V_{CC} = 3.3 V.

Pre-settable synchronous 4-bit binary counter; synchronous reset

74LV163

AC WAVEFORMS

$V_M = 1.5\text{ V}$ at $V_{CC} \geq 2.7\text{ V}$;
 $V_M = 0.5\text{ V} \times V_{CC}$ at $V_{CC} < 2.7\text{ V}$;
 V_{OL} and V_{OH} are the typical output voltage drop that occur with the output load.

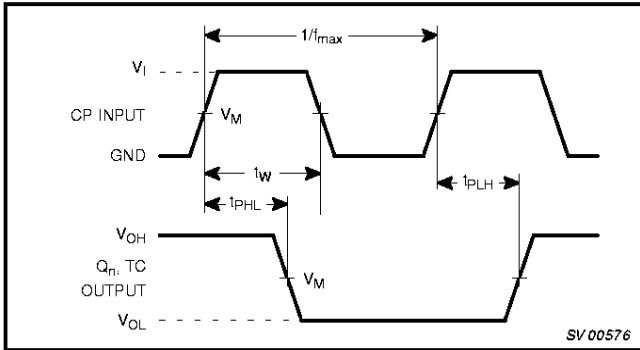

Figure 1. Clock (CP) to outputs (Q_n , TC) propagation delays, the clock pulse width and the maximum clock frequency.

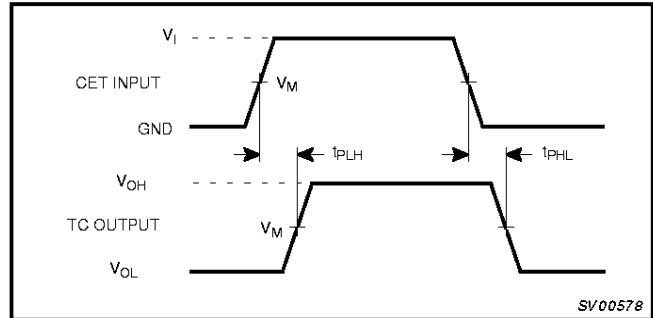

Figure 2. Input (CET) to output (TC) propagation delays and output transition times.

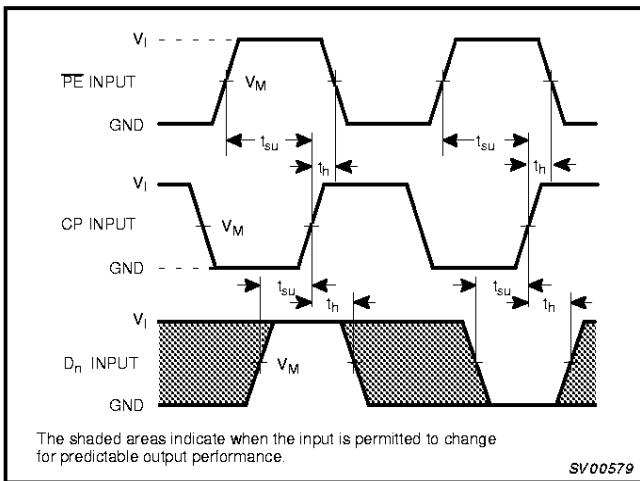

Figure 3. Set-up and hold times for input (D_n) and parallel enable input (PE).

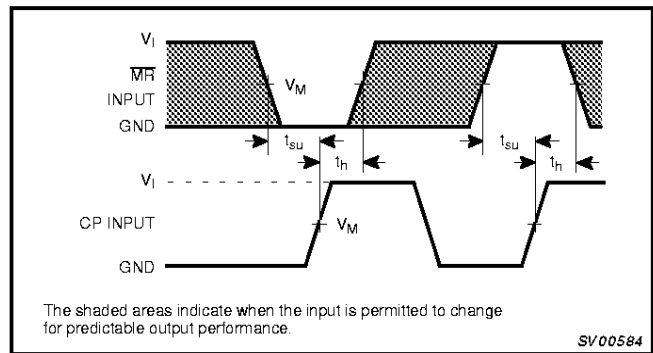

Figure 4. \overline{MR} set-up and hold times.

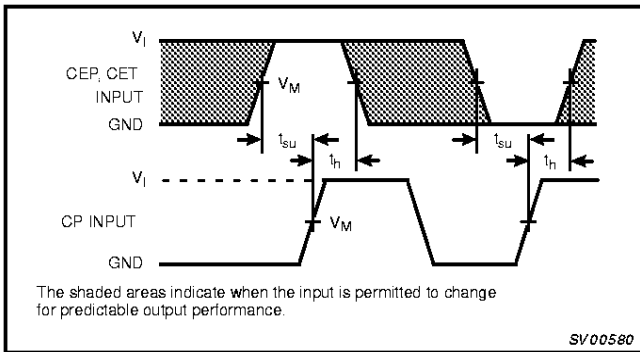

Figure 5. CEP and CET set-up and hold times.

Presettable synchronous 4-bit binary counter;
synchronous reset

74LV163

TEST CIRCUIT

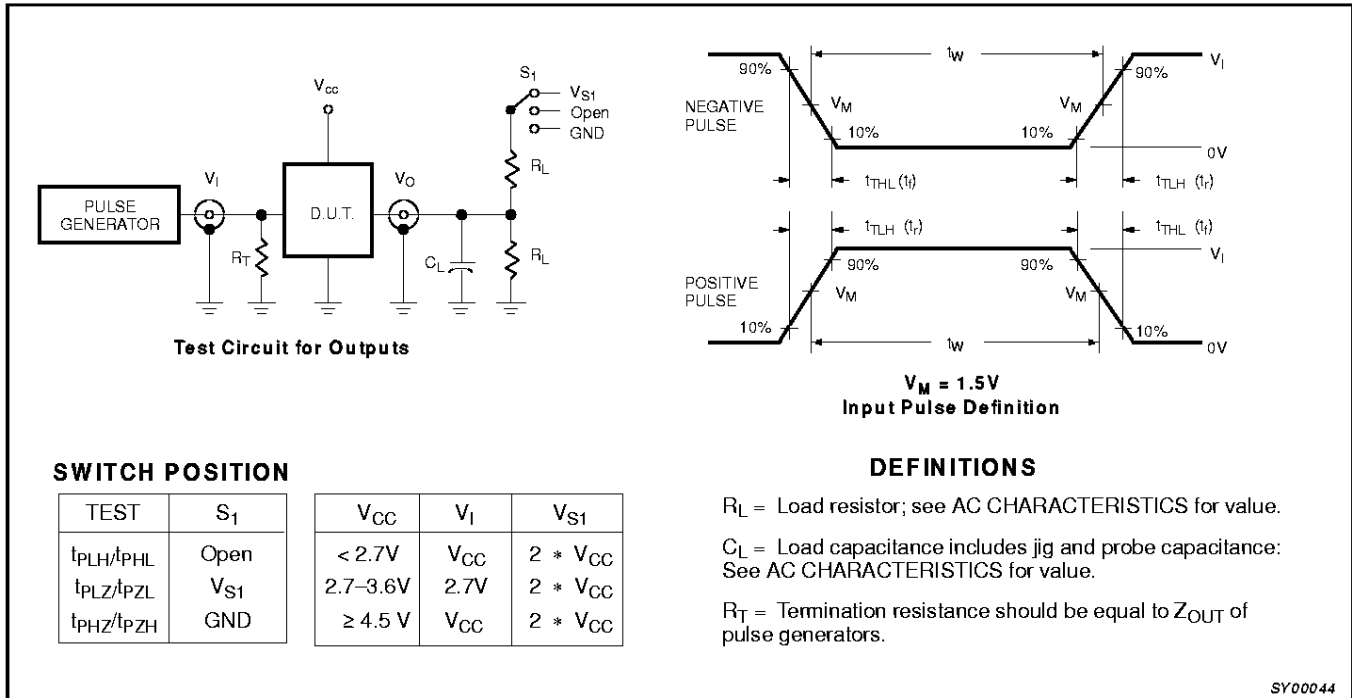

Figure 6. Load circuitry for switching times.

Pre-settable synchronous 4-bit binary counter;
synchronous reset

74LV163

DIP16: plastic dual in-line package; 16 leads (300 mil)

SOT38-4

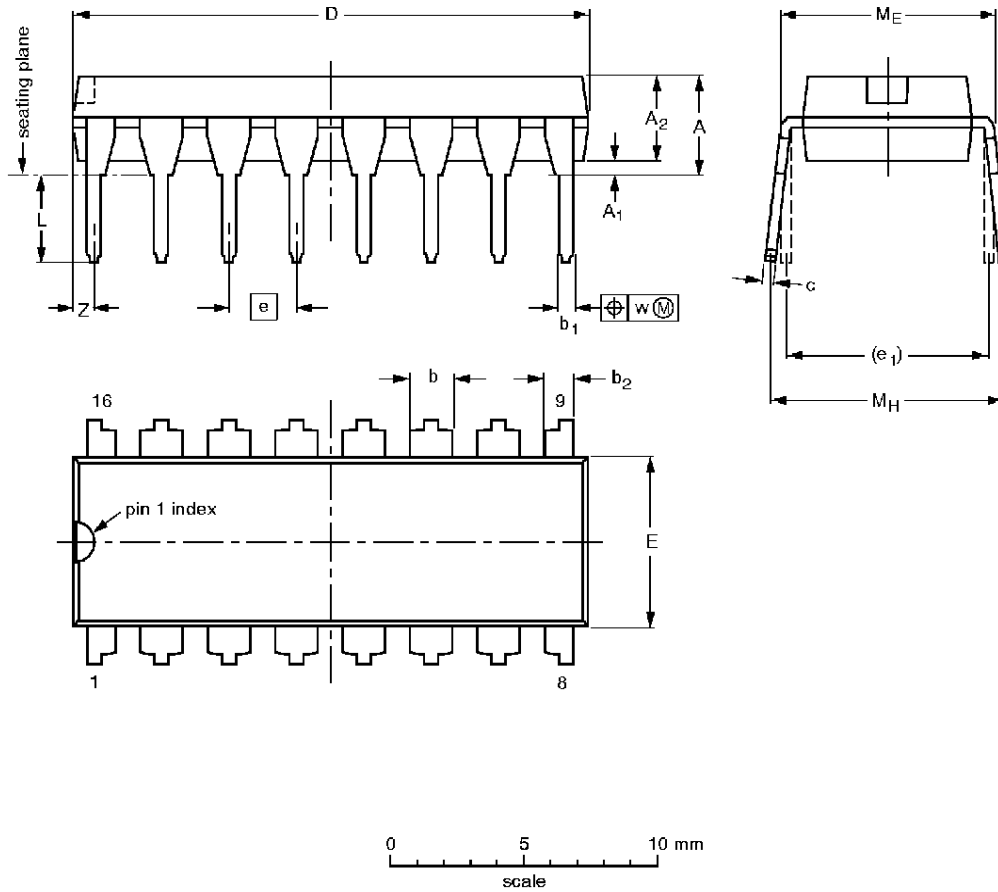

DIMENSIONS (inch dimensions are derived from the original mm dimensions)

UNIT	A max.	A ₁ min.	A ₂ max.	b	b ₁	b ₂	c	D ⁽¹⁾	E ⁽¹⁾	e	e ₁	L	M _E	M _H	w	z ⁽¹⁾ max.
mm	4.2	0.51	3.2	1.73 1.30	0.53 0.38	1.25 0.85	0.36 0.23	19.50 18.55	6.48 6.20	2.54	7.62	3.60 3.05	8.25 7.80	10.0 8.3	0.254	0.76
inches	0.17	0.020	0.13	0.068 0.051	0.021 0.015	0.049 0.033	0.014 0.009	0.77 0.73	0.26 0.24	0.10	0.30	0.14 0.12	0.32 0.31	0.39 0.33	0.01	0.030

Note

1. Plastic or metal protrusions of 0.25 mm maximum per side are not included.

OUTLINE VERSION	REFERENCES				EUROPEAN PROJECTION	ISSUE DATE
	IEC	JEDEC	EIAJ			
SOT38-4						92-11-17 95-01-14

Presettable synchronous 4-bit binary counter;
synchronous reset

74LV163

SO16: plastic small outline package; 16 leads; body width 3.9 mm

SOT109-1

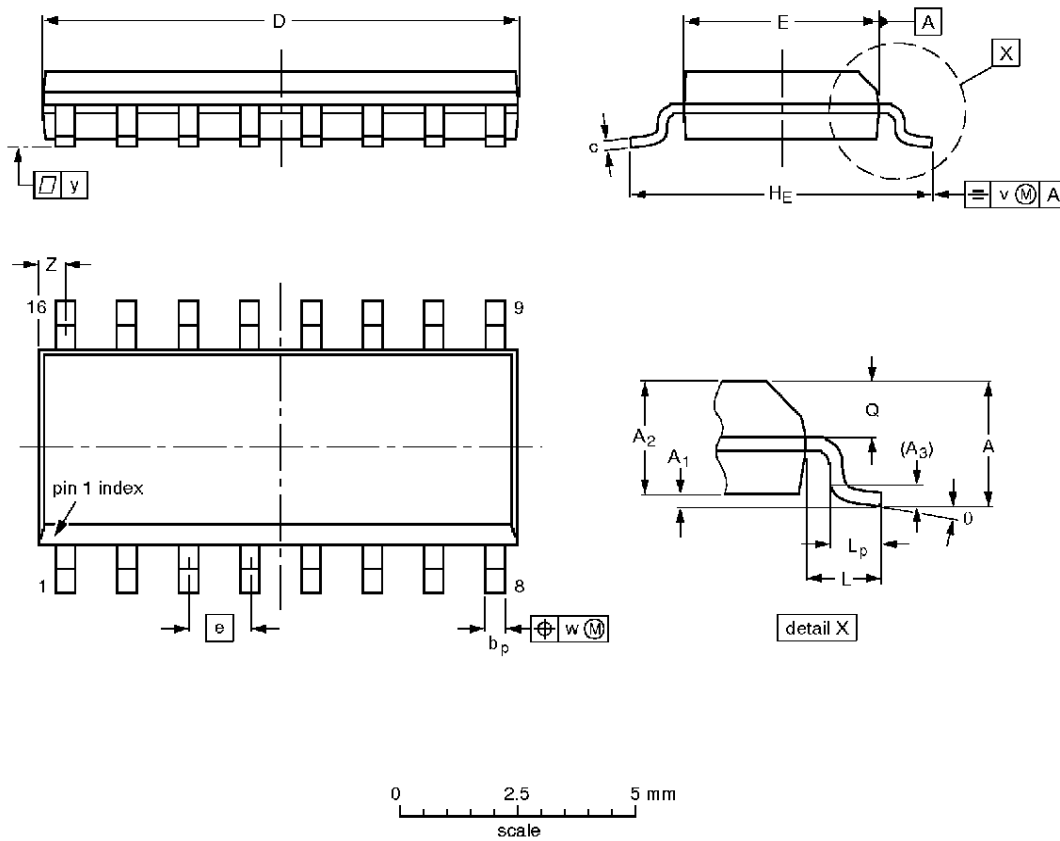

DIMENSIONS (inch dimensions are derived from the original mm dimensions)

UNIT	A max.	A ₁	A ₂	A ₃	b _p	c	D ⁽¹⁾	E ⁽¹⁾	e	H _E	L	L _p	Q	v	w	y	Z ⁽¹⁾	0
mm	1.75	0.25 0.10	1.45 1.25	0.25	0.49 0.36	0.25 0.19	10.0 9.8	4.0 3.8	1.27	6.2 5.8	1.05	1.0 0.4	0.7 0.6	0.25	0.25	0.1	0.7 0.3	8° 0°
inches	0.069	0.0098 0.0039	0.057 0.049	0.01	0.019 0.014	0.0098 0.0075	0.39 0.38	0.16 0.15	0.050	0.24 0.23	0.041	0.039 0.016	0.028 0.020	0.01	0.01	0.004	0.028 0.012	

Note

1. Plastic or metal protrusions of 0.15 mm maximum per side are not included.

OUTLINE VERSION	REFERENCES			EUROPEAN PROJECTION	ISSUE DATE
	IEC	JEDEC	EIAJ		
SOT109-1	076E07S	MS-012AC			91-08-13 95-01-23

Pre-settable synchronous 4-bit binary counter;
synchronous reset

74LV163

SSOP16: plastic shrink small outline package; 16 leads; body width 5.3 mm

SOT338-1

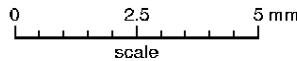
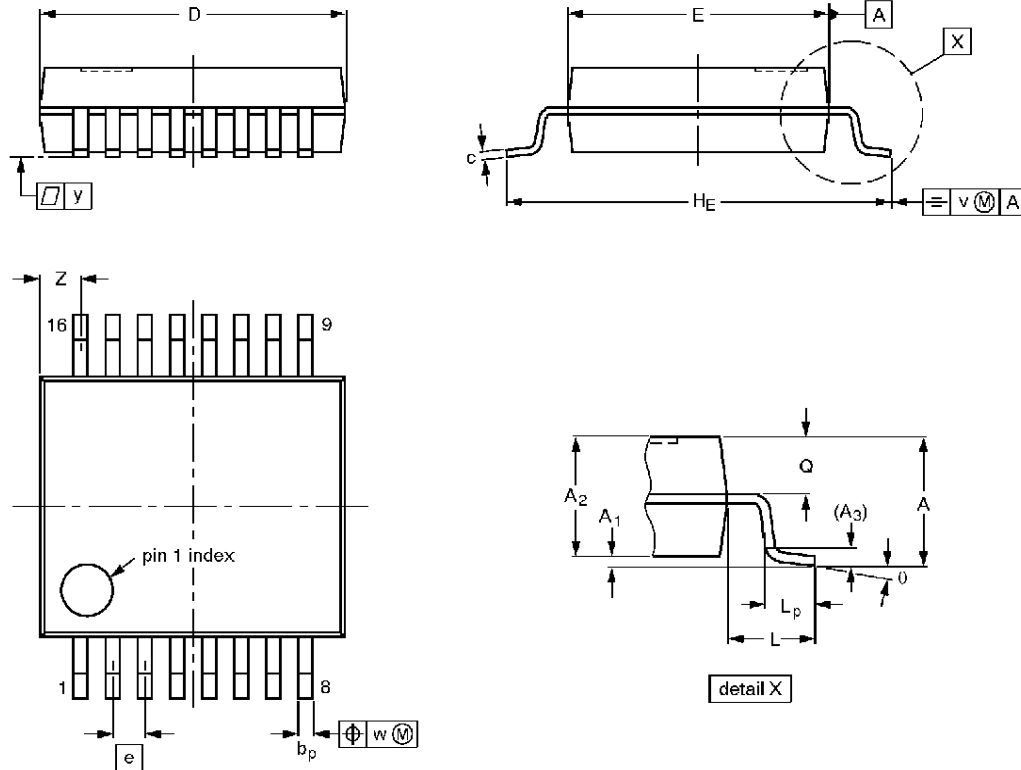

DIMENSIONS (mm are the original dimensions)

UNIT	A max.	A ₁	A ₂	A ₃	b _p	c	D ⁽¹⁾	E ⁽¹⁾	e	H _E	L	L _p	Q	v	w	y	Z ⁽¹⁾	θ
mm	2.0	0.21 0.05	1.80 1.65	0.25	0.38 0.25	0.20 0.09	6.4 6.0	5.4 5.2	0.65	7.9 7.6	1.25	1.03 0.63	0.9 0.7	0.2	0.13	0.1	1.00 0.55	8° 0°

Note

1. Plastic or metal protrusions of 0.25 mm maximum per side are not included.

OUTLINE VERSION	REFERENCES				EUROPEAN PROJECTION	ISSUE DATE
	IEC	JEDEC	EIAJ			
SOT338-1		MO-150AC				94-01-14 95-02-04

Presettable synchronous 4-bit binary counter;
synchronous reset

74LV163

TSSOP16: plastic thin shrink small outline package; 16 leads; body width 4.4 mm

SOT403-1

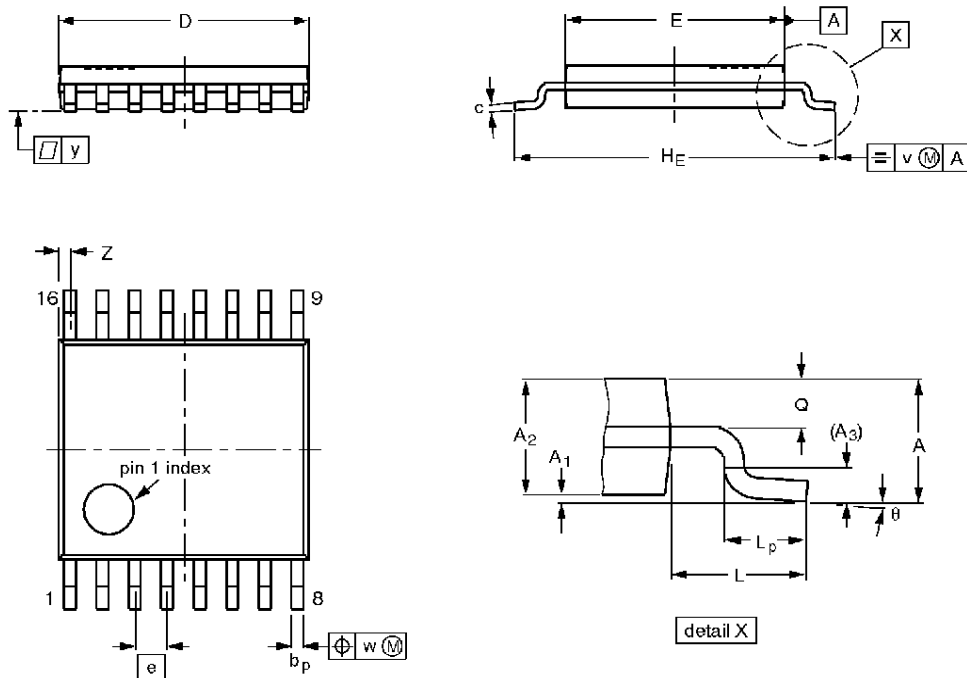

DIMENSIONS (mm are the original dimensions)

UNIT	A max.	A ₁	A ₂	A ₃	b _p	c	D ⁽¹⁾	E ⁽²⁾	e	H _E	L	L _p	Q	v	w	y	Z ⁽¹⁾	θ
mm	1.10	0.15 0.05	0.95 0.80	0.25	0.30 0.19	0.2 0.1	5.1 4.9	4.5 4.3	0.65	6.6 6.2	1.0	0.75 0.50	0.4 0.3	0.2	0.13	0.1	0.40 0.06	8° 0°

Notes

1. Plastic or metal protrusions of 0.15 mm maximum per side are not included.
2. Plastic interlead protrusions of 0.25 mm maximum per side are not included.

OUTLINE VERSION	REFERENCES				EUROPEAN PROJECTION	ISSUE DATE
	IEC	JEDEC	EIAJ			
SOT403-1		MO-153				94-07-12 95-04-04

Presetable synchronous 4-bit binary counter;
synchronous reset

74LV163

NOTES

Presetable synchronous 4-bit binary counter; synchronous reset

74LV163

DEFINITIONS

Data Sheet Identification	Product Status	Definition
<i>Objective Specification</i>	Formative or In Design	This data sheet contains the design target or goal specifications for product development. Specifications may change in any manner without notice.
<i>Preliminary Specification</i>	Preproduction Product	This data sheet contains preliminary data, and supplementary data will be published at a later date. Philips Semiconductors reserves the right to make changes at any time without notice in order to improve design and supply the best possible product.
<i>Product Specification</i>	Full Production	This data sheet contains Final Specifications. Philips Semiconductors reserves the right to make changes at any time without notice, in order to improve design and supply the best possible product.

Philips Semiconductors and Philips Electronics North America Corporation reserve the right to make changes, without notice, in the products, including circuits, standard cells, and/or software, described or contained herein in order to improve design and/or performance. Philips Semiconductors assumes no responsibility or liability for the use of any of these products, conveys no license or title under any patent, copyright, or mask work right to these products, and makes no representations or warranties that these products are free from patent, copyright, or mask work right infringement, unless otherwise specified. Applications that are described herein for any of these products are for illustrative purposes only. Philips Semiconductors makes no representation or warranty that such applications will be suitable for the specified use without further testing or modification.

LIFE SUPPORT APPLICATIONS

Philips Semiconductors and Philips Electronics North America Corporation Products are not designed for use in life support appliances, devices, or systems where malfunction of a Philips Semiconductors and Philips Electronics North America Corporation Product can reasonably be expected to result in a personal injury. Philips Semiconductors and Philips Electronics North America Corporation customers using or selling Philips Semiconductors and Philips Electronics North America Corporation Products for use in such applications do so at their own risk and agree to fully indemnify Philips Semiconductors and Philips Electronics North America Corporation for any damages resulting from such improper use or sale.

Philips Semiconductors
811 East Arques Avenue
P.O. Box 3409
Sunnyvale, California 94088-3409
Telephone 800-234-7381

© Copyright Philips Electronics North America Corporation 1997
All rights reserved. Printed in U.S.A.

Let's make things better.

Philips
Semiconductors



PHILIPS