

T-46-07-09

878



DM74AS878 Dual 4-Bit D-Type Edge-Triggered Flip-Flop with Synchronous Clear

General Description

These dual 4-bit registers feature totem-pole TRI-STATE® outputs designed specifically for driving highly-capacitive or relatively low-impedance loads. The high-impedance state and increased high-logic-level drive provide these registers with the capability of being connected directly to and driving the bus lines in a bus-organized system without need for interface or pull-up components. They are particularly attractive for implementing buffer registers, I/O ports, bidirectional bus drivers, and working registers.

The eight flip-flops of the AS878 are edge-triggered D-type flip-flops. On the positive transition of the clock, the Q outputs will be set to the logic states that were set up at the D inputs.

A buffered output control input can be used to place the eight outputs in either a normal logic state (high or low logic levels) or a high impedance state. In the high-impedance state the outputs neither load nor drive the bus lines significantly.

The output control does not affect the internal operation of the flip-flops. That is, the old data can be retained or new data can be entered even while the outputs are off.

The pinout is arranged to ease printed circuit board layout. All data inputs are on one side of the package while all outputs are on the other side.

Features

- Switching specifications at 50 pF
- Switching specifications guaranteed over full temperature and V_{CC} range
- Advanced oxide-isolated, ion-implanted Schottky TTL process
- TRI-STATE buffer-type outputs drive bus lines directly
- Synchronous clear
- Bus structured pinout

Connection Diagram

Dual-In-Line Package

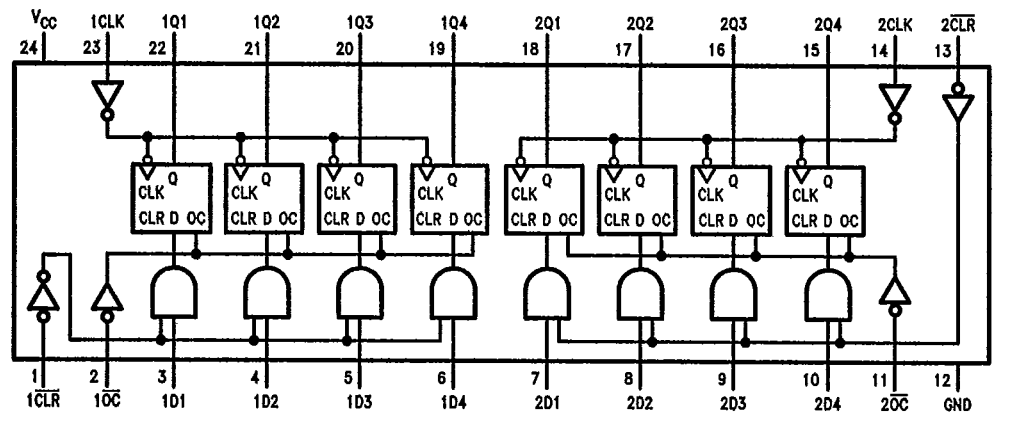

TL/F/6333-1

Order Number DM74AS878N
See NS Package Number N20A*

*Contact your local NSC representative about surface mount (M) package availability.



878

T-46-07-09

Absolute Maximum Ratings

Supply Voltage	7V
Input Voltage	7V
Voltage Applied to Disabled Output	5.5V
Operating Free Air Temperature Range	0°C to +70°C
Storage Temperature Range	-65°C to +150°C
Typical θ_{JA} N Package	47.0°C/W

Note: The "Absolute Maximum Ratings" are those values beyond which the safety of the device cannot be guaranteed. The device should not be operated at these limits. The parametric values defined in the "Electrical Characteristics" table are not guaranteed at the absolute maximum ratings. The "Recommended Operating Conditions" table will define the conditions for actual device operation.

Recommended Operating Conditions

Symbol	Parameter		Min	Nom	Max	Units
V _{CC}	Supply Voltage		4.5	5	5.5	V
V _{IH}	High Level Input Voltage		2			V
V _{IL}	Low Level Input Voltage				0.8	V
I _{OH}	High Level Output Current				-15	mA
I _{OL}	Low Level Output Current				48	mA
f _{CLK}	Clock Frequency		0		80	MHz
t _{WCLK}	Width of Enable Pulse	High	4			ns
		Low	6			
t _{SU}	Data Setup Time	Data	4 ↑			ns
		CLR	6 ↑			
t _H	Data Hold Time	Data	2 ↑			ns
		CLR	0 ↑			
T _A	Free Air Operating Temperature		0		70	ns

The (↑) arrow indicates the positive edge of the Clock is used for reference.

Electrical Characteristics

over recommended operating free air temperature range. All typical values are measured at V_{CC} = 5V, T_A = 25°C.

Symbol	Parameter	Conditions	Min	Typ	Max	Units
V _{IK}	Input Clamp Voltage	V _{CC} = 4.5V, I _I = -18 mA			-1.2	V
V _{OH}	High Level Output Voltage	V _{CC} = 4.5V, V _{IL} = V _{IL} Max, I _{OH} = Max	2.4	3.3		V
		I _{OH} = -2 mA, V _{CC} = 4.5V to 5.5V	V _{CC} - 2			V
V _{OL}	Low Level Output Voltage	V _{CC} = 4.5V, V _{IH} = 2V, I _{OL} = Max		0.35	0.5	V
I _I	Input Current @ Max Input Voltage	V _{CC} = 5.5V, V _{IH} = 7V			0.1	mA
I _{IH}	High Level Input Current	V _{CC} = 5.5V, V _{IH} = 2.7V			20	μA
I _{IL}	Low Level Input Current	V _{CC} = 5.5V, V _{IL} = 0.4V			-0.5	mA
I _O (Note 2)	Output Drive Current	V _{CC} = 5.5V, V _O = 2.25V	-30		-112	mA
I _{OZH}	Off-State Output Current, High Level Voltage Applied	V _{CC} = 5.5V, V _{IH} = 2V, V _O = 2.7V			50	μA
I _{OZL}	Off-State Output Current, Low Level Voltage Applied	V _{CC} = 5.5V, V _{IH} = 2V, V _O = 0.4V			-50	μA
I _{CC}	Supply Current	V _{CC} = 5.5V Outputs Open	Outputs High	82	132	mA
			Outputs Low	96	155	
			Outputs Disabled	100	160	

Note 2: The output conditions have been chosen to produce a current that closely approximates one-half of the true short circuit current.

T-46-07-09

878

Switching Characteristics over recommended operating free air temperature range (Note 1)

Symbol	Parameter	Conditions	From	To	DM74AS878		Units
					Min	Max	
f_{MAX}	Maximum Clock Frequency	$V_{CC} = 4.5V$ to $5.5V$ $R_L = 500\Omega$ $C_L = 50 pF$			80		MHz
t_{PLH}	Propagation Delay Time Low to High Level Output		Clock	Any Q	3	8.5	ns
t_{PHL}	Propagation Delay Time High to Low Level Output		Clock	Any Q	4	10.5	ns
t_{pZH}	Output Enable Time to High Level Output		$\overline{\text{Output Control}}$	Any Q	2	7	ns
t_{pZL}	Output Enable Time to Low Level Output		$\overline{\text{Output Control}}$	Any Q	3	10.5	ns
t_{PHZ}	Output Disable Time from High Level Output		$\overline{\text{Output Control}}$	Any Q	2	6	ns
t_{PLZ}	Output Disable Time from Low Level Output		$\overline{\text{Output Control}}$	Any Q	2	6	ns

Note 1: See Section 1 for test waveforms and output load.

Logic Diagram

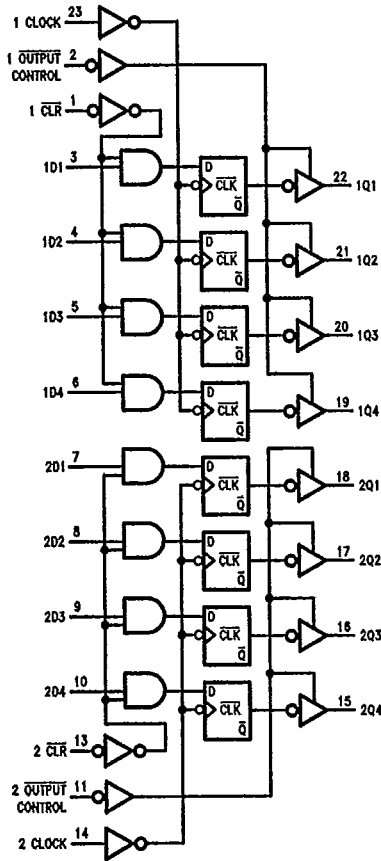

TL/F/6333-2

Function Table

CLR	D	Inputs			Output Q
		CLK	$\overline{\text{OC}}$	Q	
X	X	X	H	Z	
L	X	\uparrow	L	L	
H	H	\uparrow	L	H	
H	L	\uparrow	L	L	
H	X	L	L	Q_0	

L = Low State, H = High State, X = Don't Care

\uparrow = Positive Edge Transition

Z = High Impedance State

Q_0 = Previous Condition of Q

