

245

# Octal Bus Transceiver, NINV (3 State)

This device contains eight pairs of 3-state logic elements designed for asynchronous two-way communication between data buses. These circuits are suited for use in memory, microprocessor systems and asynchronous bi-directional data buses. The Enable input ( $\bar{E}$ ) can be used to isolate the buses.

- AVG's LS operates over extended  $V_{CC}$  from 4.5 to 5.5 V
- AVG's LS and ALS both have guaranteed DC and AC specification over full temperature and  $V_{CC}$  range
- Switching specifications for ALS at 50 pF
- AVG's ALS has the lowest speed power product (4pJ per gate typical) of all logic series

DV74LS245  
DV74ALS245A



P Suffix  
Plastic DIP  
AVG-005 Case

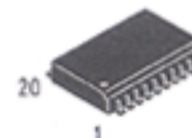

D Suffix  
Plastic SOP  
AVG-006 Case

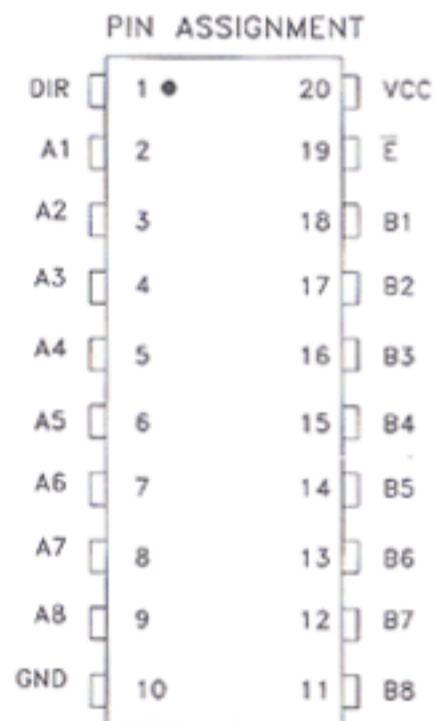
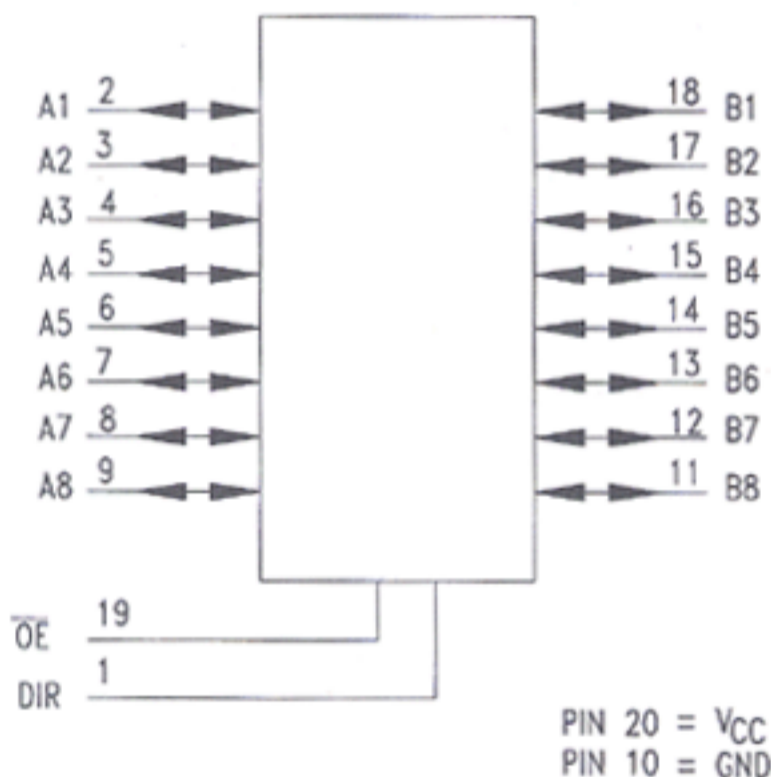

TRUTH TABLE

Inputs		Outputs
$\bar{OE}$	DIR	
L	L	B Data to Bus A
L	H	A Data to Bus B
H	X	High-Z State

H=High Logic Level  
L=Low Logic Level  
X=Immaterial

**ABSOLUTE MAXIMUM RATINGS**

Maximum ratings are those values beyond which damage to the device may occur.

Symbol	Parameter	LS245	ALS245A	Unit
V <sub>CC</sub>	Supply Voltage	7.0	7.0	V
V <sub>IN</sub>	Input Voltage	7.0	7.0	V
T <sub>STG</sub>	Storage Temperature Range	-65 to +150	-65 to +150	°C

**GUARANTEED OPERATING CONDITIONS**

Symbol	Parameter	LS245		ALS245A		Unit
		Min	Max	Min	Max	
V <sub>CC</sub>	Supply Voltage	4.5	5.5	4.5	5.5	V
V <sub>IH</sub>	High Level Input Voltage	2.0		2.0		V
V <sub>IL</sub>	Low Level Input Voltage		0.8		0.8	V
I <sub>OH</sub>	High Level Output Current		-15		-15	mA
I <sub>OL</sub>	Low Level Output Current		24		24	mA
T <sub>A</sub>	Ambient Temperature Range	-10 to +70		-10 to +70		°C

**DC ELECTRICAL CHARACTERISTICS** over full operating conditions

Symbol	Parameter	Conditions	LS245			ALS245A			Units
			Min	Typ	Max	Min	Typ	Max	
V <sub>IK</sub>	Input Clamp Voltage	V <sub>CC</sub> = min, I <sub>IN</sub> = -18 mA			-1.5			-1.5	V
V <sub>OH</sub>	High Level Output Voltage	V <sub>CC</sub> =min, I <sub>OH</sub> =-3.0 mA	2.4	3.4		2.4	3.2		V
		V <sub>CC</sub> =min., I <sub>OH</sub> =Max	2.0			2.0			V
V <sub>OL</sub>	Low Level Output Voltage	V <sub>CC</sub> =min; I <sub>OL</sub> =12 mA		0.25	0.4		0.25	0.4	V
		V <sub>CC</sub> =min; I <sub>OL</sub> =24 mA		0.35	0.5		0.35	0.5	V
V <sub>T+</sub> - V <sub>T-</sub>	Hysteresis	V <sub>CC</sub> =min	0.2	0.4			0.2	0.4	V
I <sub>IH</sub>	High Level Input Current	V <sub>CC</sub> =max, V <sub>IN</sub> = 2.7V			20			20	µA
		V <sub>CC</sub> =max, V <sub>IN</sub> = 7V			0.1			0.1	mA
I <sub>IL</sub>	Low Level Input Current	V <sub>CC</sub> =max, V <sub>IN</sub> =0.4V			-0.2			-0.1	mA
I <sub>O</sub>	Output Short Circuit Current	V <sub>CC</sub> =max; V <sub>O</sub> =2.25V	-40		-225	-30		-112	mA
I <sub>OZH</sub>	High Level 3-State Output Current	V <sub>CC</sub> =max, V <sub>OUT</sub> = 2.7V;			20				µA
I <sub>OZL</sub>	Low Level 3-State Output Current	V <sub>CC</sub> =max, V <sub>OUT</sub> =0.4V			-200				µA
I <sub>CC</sub>	Supply Current	V <sub>CC</sub> =max	Outputs High		70		30	45	mA
			Outputs Low		90		36	55	mA
			3-State (High Z)		95		38	58	mA



SWITCHING CHARACTERISTICS over full operating conditions

Symbol	Parameter	From	To	LS245 $C_L=45\text{ pF}$ $R_L=667\Omega$		ALS245A $C_L=50\text{ pF}$ $R_L=500\Omega$		Unit
				Min	Max	Min	Max	
$t_{PLH}$	Propagation Delay Time, Low-to-High Level Output	A or B	Output		12	3	10	ns
$t_{PHL}$	Propagation Delay Time High-to-Low Level Output	A or B	Output		12	3	10	ns
$t_{PZH}$	Output Enable Time to High Level	OE	Output		40	5	20	ns
$t_{PZL}$	Output Enable Time to Low Level	OE	Output		40	5	20	ns
$t_{PHZ}$	Output Disable Time from High Level	OE	Output			2	10	ns
$t_{PLZ}$	Output Disable Time From Low Level	OE	Output			4	15	ns
$t_{PHZ}$	Output Disable Time from High Level $C_L=5\text{ pF}$	OE	Output		25			ns
$t_{PLZ}$	Output Disable Time From Low Level, $C_L=5\text{ pF}$	OE	Output		25			ns

SWITCHING WAVEFORMS

