

SN54ACT16245, 74ACT16245 16-BIT BUS TRANSCEIVERS WITH 3-STATE OUTPUTS

SCAS097B – DECEMBER 1989 – REVISED APRIL 1996

- Members of the Texas Instruments *Widebus™* Family
- Inputs Are TTL-Voltage Compatible
- 3-State Outputs Drive Bus Lines Directly
- Flow-Through Architecture Optimizes PCB Layout
- Distributed V_{CC} and GND Configuration to Minimize High-Speed Switching Noise
- *EPIC™* (Enhanced-Performance Implanted CMOS) 1- μ m Process
- 500-mA Typical Latch-Up Immunity at 125°C
- Package Options Include Plastic 300-mil Shrink Small-Outline (DL) Packages Using 25-mil Center-to-Center Pin Spacings, Thin Shrink Small-Outline (DGG) Packages, and 380-mil Fine-Pitch Ceramic Flat (WD) Packages Using 25-mil Center-to-Center Pin Spacings

description

The SN54ACT16245 and 74ACT16245 are 16-bit bus transceivers organized as dual-octal noninverting 3-state transceivers and designed for asynchronous two-way communication between data buses. The control-function implementation minimizes external timing requirements.

The devices allow data transmission from the A bus to the B bus or from the B bus to the A bus, depending on the logic level at the direction-control (DIR) input. The enable (\bar{G}) input can be used to disable the devices so that the buses are effectively isolated.

The SN54ACT16245 is characterized for operation over the full military temperature range of -55°C to 125°C . The 74ACT16245 is characterized for operation from -40°C to 85°C .

SN54ACT16245 ... WD PACKAGE
74ACT16245 ... DGG OR DL PACKAGE
(TOP VIEW)

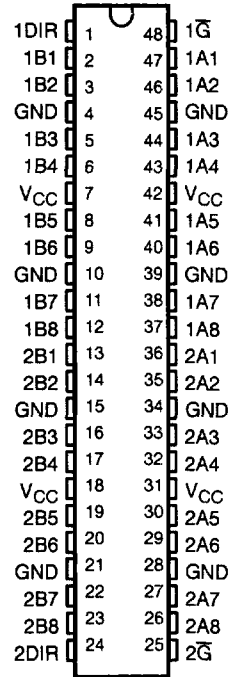

FUNCTION TABLE

CONTROL INPUTS		OPERATION
\bar{G}	DIR	
L	L	B data to A bus
L	H	A data to B bus
H	X	Isolation

EPIC and Widebus are trademarks of Texas Instruments Incorporated.

PRODUCTION DATA Information is current as of publication date. Products conform to specifications per the terms of Texas Instruments standard warranty. Production processing does not necessarily include testing of all parameters.



POST OFFICE BOX 655303 • DALLAS, TEXAS 75265

Copyright © 1996, Texas Instruments Incorporated

SN54ACT16245, 74ACT16245 16-BIT BUS TRANSCEIVERS WITH 3-STATE OUTPUTS

SCAS097B - DECEMBER 1989 - REVISED APRIL 1996

logic symbol†

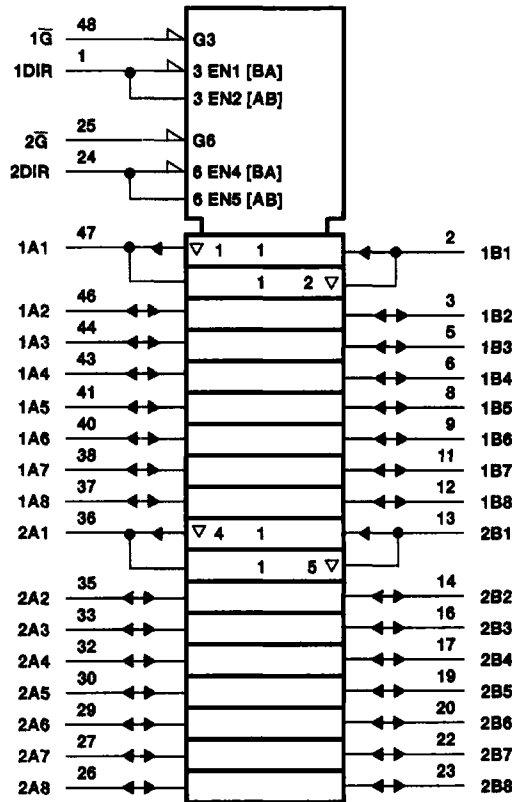

† This symbol is in accordance with ANSI/IEEE Std 91-1984 and IEC Publication 617-12.

logic diagram (positive logic)

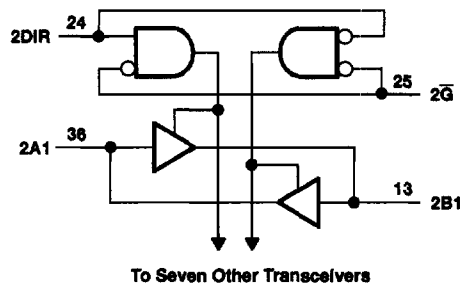
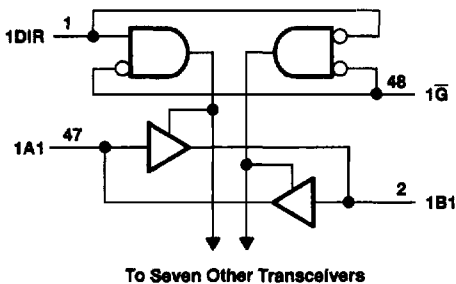

POST OFFICE BOX 655303 • DALLAS, TEXAS 75265

SN54ACT16245, 74ACT16245
16-BIT BUS TRANSCEIVERS
WITH 3-STATE OUTPUTS

SCAS007B - DECEMBER 1989 - REVISED APRIL 1996

absolute maximum ratings over operating free-air temperature range (unless otherwise noted)†

Supply voltage, V_{CC}	-0.5 V to 7 V
Input voltage range, V_I (see Note 1)	-0.5 V to $V_{CC} + 0.5$ V
Output voltage range, V_O (see Note 1)	-0.5 V to $V_{CC} + 0.5$ V
Input clamp current, I_{IK} ($V_I < 0$ or $V_I > V_{CC}$)	± 20 mA
Output clamp current, I_{OK} ($V_O < 0$ or $V_O > V_{CC}$)	± 50 mA
Continuous output current, I_O ($V_O = 0$ to V_{CC})	± 50 mA
Continuous current through V_{CC} or GND	± 400 mA
Maximum power dissipation at $T_A = 55^\circ\text{C}$ (in still air) (see Note 2): DGG package	0.85 W
DL package	1.2 W
Storage temperature range, T_{stg}	-65°C to 150°C

† Stresses beyond those listed under "absolute maximum ratings" may cause permanent damage to the device. These are stress ratings only, and functional operation of the device at these or any other conditions beyond those indicated under "recommended operating conditions" is not implied. Exposure to absolute-maximum-rated conditions for extended periods may affect device reliability.

- NOTES: 1. The input and output voltage ratings may be exceeded if the input and output current ratings are observed.
 2. The maximum package power dissipation is calculated using a junction temperature of 150°C and a board trace length of 750 mils.

recommended operating conditions (see Note 3)

	SN54ACT16245		74ACT16245		UNIT
	MIN	MAX	MIN	MAX	
V_{CC} Supply voltage (see Note 4)	4.5	5.5	4.5	5.5	V
V_{IH} High-level input voltage	2		2		V
V_{IL} Low-level input voltage		0.8		0.8	V
V_I Input voltage	0	V_{CC}	0	V_{CC}	V
V_O Output voltage	0	V_{CC}	0	V_{CC}	V
I_{OH} High-level output current		-24		-24	mA
I_{OL} Low-level output current		24		24	mA
$\Delta t/\Delta v$ Input transition rise or fall rate	0	10	0	10	ns/V
T_A Operating free-air temperature	-55	125	-40	85	$^\circ\text{C}$

- NOTES: 3. Unused inputs should be tied to V_{CC} through a pullup resistor of approximately 5 k Ω or greater to keep them from floating.
 4. All V_{CC} and GND pins must be connected to the proper voltage power supply.



SN54ACT16245, 74ACT16245
16-BIT BUS TRANSCEIVERS
WITH 3-STATE OUTPUTS

SCAS097B – DECEMBER 1989 – REVISED APRIL 1996

electrical characteristics over recommended operating free-air temperature range (unless otherwise noted)

PARAMETER	TEST CONDITIONS	V _{CC}	T _A = 25°C			SN54ACT16245		74ACT16245		UNIT
			MIN	TYP	MAX	MIN	MAX	MIN	MAX	
V _{OH}	I _{OH} = -50 μA	4.5 V	4.4			4.4		4.4	V	
		5.5 V	5.4			5.4		5.4		
	I _{OH} = -24 mA	4.5 V	3.94			3.94		3.8		
		5.5 V	4.94			4.94		4.8		
	I _{OH} = -50 mA [†]	5.5 V				3.85				
I _{OH} = -75 mA [†]	5.5 V						3.85			
V _{OL}	I _{OL} = 50 μA	4.5 V			0.1		0.1	0.1	V	
		5.5 V			0.1		0.1	0.1		
	I _{OL} = 24 mA	4.5 V			0.36		0.5	0.44		
		5.5 V			0.36		0.5	0.44		
	I _{OL} = 50 mA [†]	5.5 V					1.65			
I _{OL} = 75 mA [†]	5.5 V						1.65			
I _I	Control inputs	V _I = V _{CC} or GND	5.5 V			±0.1		±1	±1	μA
I _{OZ}	A or B ports [‡]	V _O = V _{CC} or GND	5.5 V			±0.5		±10	±5	μA
I _{CC}		V _I = V _{CC} or GND, I _O = 0	5.5 V			8		160	80	μA
ΔI _{CC} [§]		One input at 3.4 V, Other inputs at GND or V _{CC}	5.5 V			0.9		1	1	mA
C _i	Control inputs	V _I = V _{CC} or GND	5 V			4.5				pF
C _{io}	A or B ports	V _O = V _{CC} or GND	5 V			16				pF

[†] Not more than one output should be tested at a time, and the duration of the test should not exceed 10 ms.

[‡] For I/O ports, the parameter I_{OZ} includes the input leakage current I_I.

[§] This is the increase in supply current for each input that is at one of the specified TTL voltage levels rather than 0 V or V_{CC}.

switching characteristics over recommended ranges of supply voltage and operating free-air temperature (unless otherwise noted) (see Figure 1)

PARAMETER	FROM (INPUT)	TO (OUTPUT)	T _A = 25°C			SN54ACT16245		74ACT16245		UNIT
			MIN	TYP	MAX	MIN	MAX	MIN	MAX	
t _{PLH}	A or B	B or A	3.2	6.9	9.3	3.2	11.5	3.2	10.5	ns
t _{PHL}			2.6	6.4	9.2	2.6	11.1	2.6	10.2	
t _{PZH}	\bar{G}	B or A	2.7	6.4	9.1	2.7	10.9	2.7	10	ns
t _{PZL}			3.4	7.4	10.5	3.4	12.6	3.4	11.6	
t _{PHZ}	\bar{G}	B or A	5.8	9.2	11.6	5.8	13.4	5.8	12.6	ns
t _{PLZ}			5.5	8.5	10.8	5.5	12.7	5.5	11.8	

operating characteristics, V_{CC} = 5 V, T_A = 25°C

PARAMETER		TEST CONDITIONS	TYP	UNIT
C _{pd}	Power dissipation capacitance per transceiver	C _L = 50 pF, f = 1 MHz	52	pF
			10	



PARAMETER MEASUREMENT INFORMATION

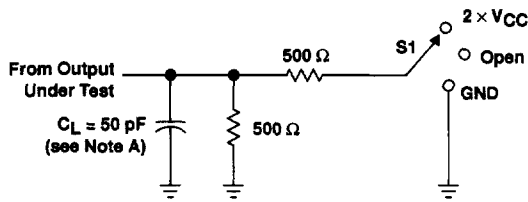

LOAD CIRCUIT

TEST	S1
t_{PLH}/t_{PHL}	Open
t_{PLZ}/t_{PZL}	$2 \times V_{CC}$
t_{PHZ}/t_{PZH}	GND

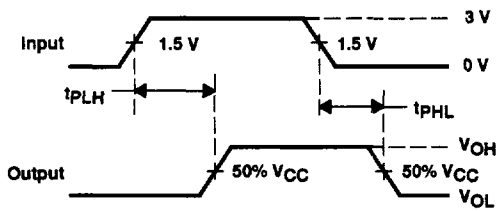

VOLTAGE WAVEFORMS

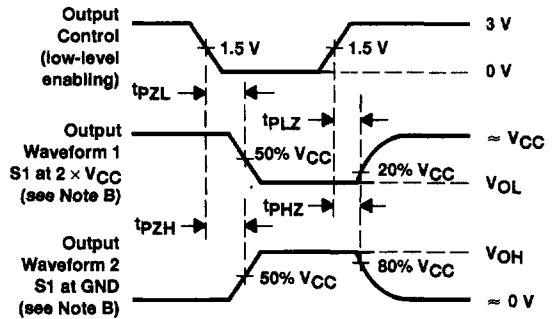

VOLTAGE WAVEFORMS

- NOTES: A. C_L includes probe and jig capacitance.
 B. Waveform 1 is for an output with internal conditions such that the output is low except when disabled by the output control. Waveform 2 is for an output with internal conditions such that the output is high except when disabled by the output control.
 C. All input pulses are supplied by generators having the following characteristics: PRR $\leq 1 \text{ MHz}$, $Z_O = 50 \Omega$, $t_r = 3 \text{ ns}$, $t_f = 3 \text{ ns}$.
 D. The outputs are measured one at a time with one input transition per measurement.

Figure 1. Load Circuit and Voltage Waveforms